



# Lean Tube System

唯杰自动化设备科技(东莞市)有限公司  
WJ-LEAN TECHNOLOGY COMPANY LIMITED

# COMPANY INTRODUCTION

## 公司介绍

唯杰自动化设备科技有限公司是一家专注于工业建设及其技术解决方案的有限公司。公司总部位于广东东莞，市场布局覆盖全球，在全球多个国家设有综合服务机构。产品广泛应用于机械框架结构及各类零件连接，工业流水线和传送带，小型机动设备及非标机电设备，工业检验检测及安全防护设备。包含电子、汽车零部件装配生产线，家电、化工、家具广告、医疗食品、清洁设备等领域。直至 2022 年，唯杰已向全世界提供超过上千种产品。

唯杰拥有专业的研发团队，在生产系统模块研发与生产方面的行业经验超过 10 年。依靠多年积累的专业技术经验和强大的研发创新能力，使得公司产品深深具

备工业耐用性，灵活便捷性，易于组装和调整性，完全可以重复使用。我们设计制造的模块化构造系统能够快速创建各种结构并保证牢固，产品品质及系统方案一直在同行业中保持领先水平。

我们使用高度可调节机制和执行器以及其他必要的解决方案来交付功能齐全的产品。公司具备所有的行业产品系统，包括不限于 MB 工业铝型材装配系统，精益生产系统、线性模组系统、工作台系统及小型梯建平台系统。为精益生产自动化、人体工学和未来智能制造提供先进的解决方案。

WJ-LEAN Technology Company Limited is a focusing on industrial construction and its technical solutions. The company is headquartered in Dongguan, Guangdong, with a global market layout and comprehensive service agencies in many countries. Products are widely used in mechanical frame structure and various parts connection, industrial assembly line and conveyor belt, small motor equipment and non-standard mechanical and electrical equipment, industrial inspection and testing and safety protection equipment. Including electronics, auto parts assembly lines, home appliances, chemicals, furniture advertising, medical food, cleaning equipment and other fields. By 2022, WJ-LEAN has provided more than a thousand products to the world.

We use highly adjustable mechanisms and actuators as well as other necessary solutions to deliver fully functional products. The company has all industry product systems, including but not limited to MB industrial aluminum profile assembly system, lean production system, linear module system, workbench system and small elevator platform system. Provide advanced solutions for lean production automation, ergonomics and future intelligent manufacturing.



# CONTENTS

<b>φ=28MM</b>	<b>4</b>
PIPES 复合管	4
METAL JOINT 五金接头	9
<b>φ=28.6MM</b>	<b>19</b>
PIPES 复合管	19
METAL JOINT 五金接头	24
<b>PLASTIC JOINTS 塑料接头</b>	<b>26</b>
<b>ROLLER TRACKS 滑轨</b>	<b>30</b>
STEEL ROLLER PLACON 铁滑轨	31
ALUMINUM ROLLER PLACON 铝滑轨	34
<b>MOUNTING BRACKETS 滑轨接头</b>	<b>35</b>
<b>ACCESSORIES 配件</b>	<b>42</b>
CASTER 脚轮	43
ADJUST 脚杯及其附件	46
BUSHING NUT 铜套螺母	48
PLASTIC STRIP 塑胶条	50
METAL ACCESSORIES 五金配件	53
PLASTIC FOOT COVER 塑料脚套	59
CAP 封盖	59
BOLT AND NUT 螺丝螺母	60
<b>TECHNICAL SPECIFICATIONS 技术参数</b>	<b>64</b>

精益材料的专业提供者 ▶

Lean material professional supplier





DETAILED DESCRIPTION OF COATED PIPE  $\Phi=28\text{MM}$   
28MM 复合管详细说明

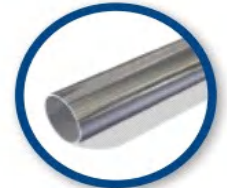
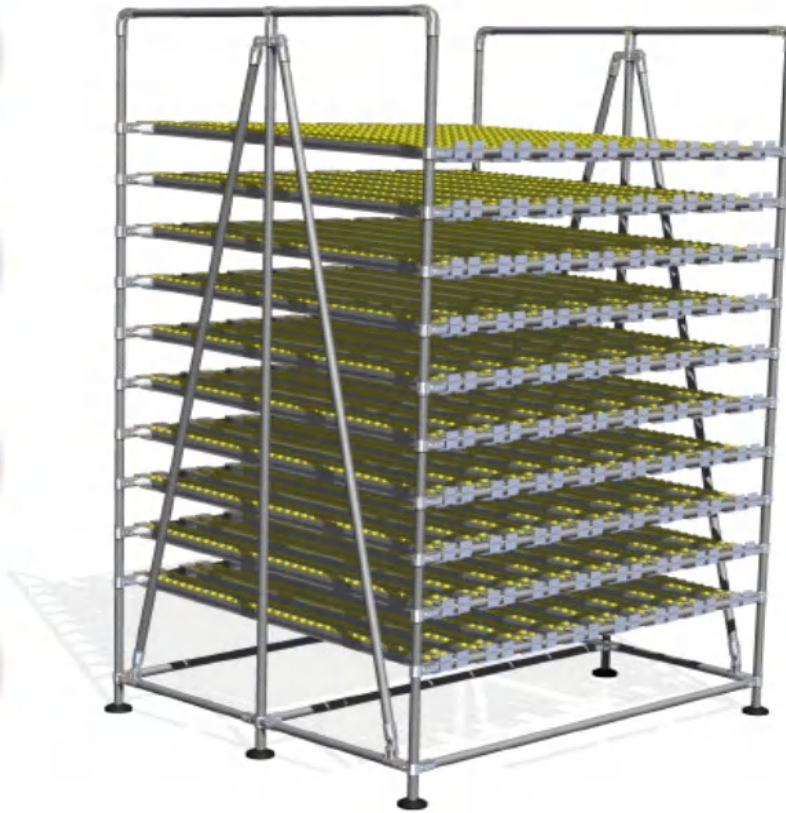

NAMED OF  
PRODUCT  
品名

CP-28T	normal coated pipe
CP-28T-ESD	ESD coated pipe
SP-28T	slide pipe
SPS-28T	stainless steel pipe
PCP-28T	Powder coated pipe
FT-28T	flat pipe

T=0.7mm 0.8mm 1.0mm 1.2mm 1.5mm 2.0mm





STANDARD COLOR OF COATED PIPE

复合管标准颜色



	IV:Ivory
	WH:White
	SB:Sky Blue
	DB:Dark Blue
	RE:Red
	GR:Green
	YE:Yellow
	BE:Beige
	LG:Light Gray
	DG:Dark Gray
	BK:Black
	EBK: ESD Black
	ESD GRAY
	ESD IVORY

※T=THICKNESS 厚度

07=T0.7

08=T0.8

10=T1.0

12=T1.2

15=T1.5

20=T2.0

※LENGTH 长度

- customizable

※CUSTOMIZABLE 可定制的







- color we can do it according customer sample, The MOQ is 1000PCS

※ 

- means accept any quantity

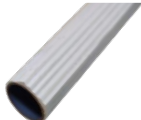
# COATED PIPE(28MM)

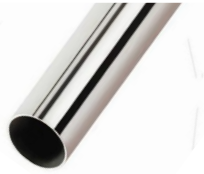
## 28mm 复合管

Part Number	Dimension	Weight	Capacity	MOQ	Classification	Standard Length	Color	Photo
	(mm)	(g/meter)	(kg/m)	(pcs)		(mm)		
CP-2807	Φ28*0.7	505	45	◎	Coated Pipe	4000	IV (ESD) WH SB DB RE GR (ESD) YE BE LG BK	
CP-2808	Φ28*0.8	680	70	◎				
CP-2810	Φ28*1.0	700	100	◎				
CP-2812	Φ28*1.2	800	120	500				
CP-2815	Φ28*1.5	1000	150	1000				
CP-2820	Φ28*2.0	1300	200	500				
CP-2807ESD	Φ28*0.7	505	45	◎	Coated Pipe	4000	EBK ESD Gray	
CP-2810ESD	Φ28*1.0	700	100	◎				
CP-2812ESD	Φ28*1.2	800	120	500				
CP-2815ESD	Φ28*1.5	1000	150	1000				
CP-2820ESD	Φ28*2.0	1300	200	500				
SP-2810	Φ28*1.0	770	100	750	Slide Pipe	4000	IV	
PCP-2810	Φ28*1.0	600		◎	Powder Coated Pipe (PCP)	4000	Any colour	
PCP-2820	Φ28*2.0	1300		◎		4000		
FT-2810	Φ28*1.0	790		◎	Flat Pipe	4000	IV	
SPS-2807	Φ28*0.7	500	40	500	SUS439 SUS201 SUS304	4000	Sliver	
SPS-2810	Φ28*1.0	670	90	500				
SPS-2812	Φ28*1.2	780	110	750				
AL-2810	Φ28*1.0	550			Aluminum pipe	4000	Sliver	
AL-2820	Φ28*2.0	1200						



FEATURES OF D-COAT PIPE

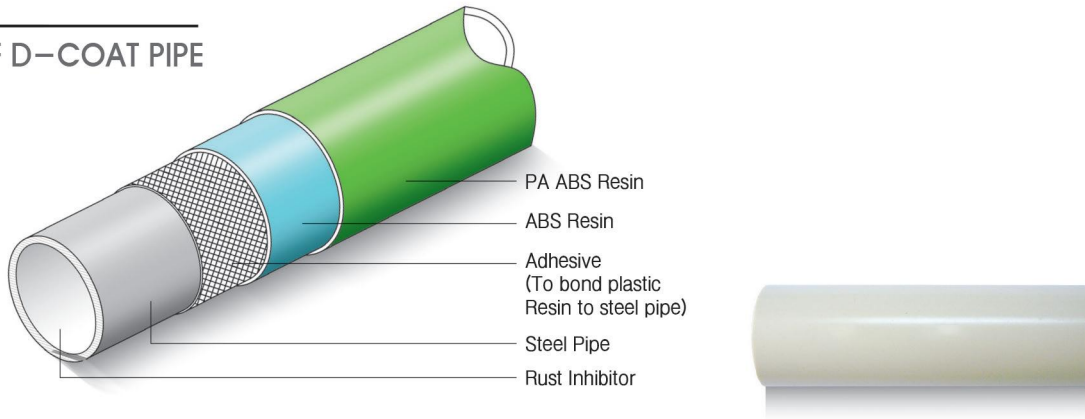

1. Steel pipe is coated with ABS. Then, the surface is coated again with the new material of PA ABS.
2. Compared to the conventional ABS coating pipe, D-Coat Pipe is outstanding in oil resistance and chemical resistance. In particular, salinity, rust preventative oil or cutting oil does not cause cracks or discoloration of the pipe.
3. This product comes in a variety of colors for use in various items or per company's image.
4. With outstanding durability, this pipe is easily processed. Rustproof coating inside the pipe provides superior corrosion resistance.

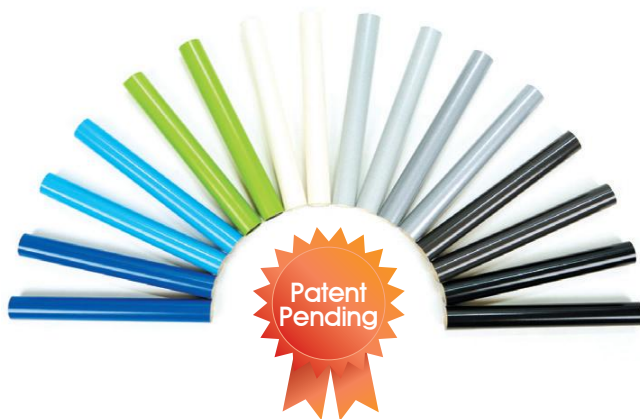

1. **Environmental**
  - ECO-pipe is fully recyclable.
  - Powder painted steel pipe of internal and external surface
2. **Economical**
  - 20% less than coated pipe
  - 35% less than ESD coated pipe
  - 30% less than stainless steel pipe

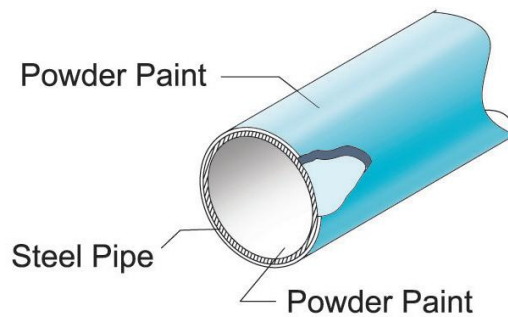

3. **Colorful**
  - Wider selection of colors and textures.
4. **Chemical resistant**
  - High resistant to oil, UV light, and corrosion.
5. **Non-flammable**
  - No emission of toxic fumes in fire.
6. **Electrolytic Corrosion Free**
  - Free of Electrolytic Corrosion.





# COATED PIPE 复合管

## THE ADVANTAGES OF STAINLESS PIPE

- 1. **Environmental**
  - Stainless pipe which is 100% recycable
- 2. **High Strength & Durability**
  - Surface resistant to light abrasion or contact with metal tools
- 3. **High Oil & Chemical Resistance**
  - High resistance to oil, solvents, bleaches, etc.
- 4. **Non-Flammable**
  - Inherently non-flammable.
- 5. **Conductive**
  - Inherently conductive



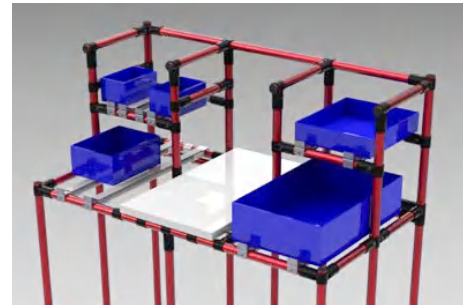
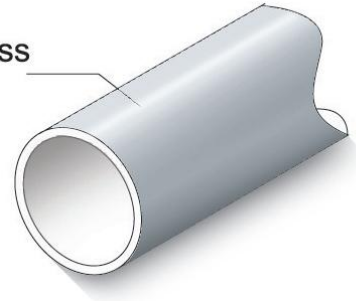

Stainless Pipe



# METAL JOINTS 金属接头



## ※COLOR 颜色

	Black	BK
	Zinc	ZN
	Chrome	CN
	Nickel	NI

## ※MATERIAL 材料

- SPCC、SUS 304

## ※THICKNESS 厚度

- 2.5mm

## ※PRODUCT DETAILS 产品细节

can be punched and fixed



Innovated Joint with Assembly help line



the side pressing line of the hardware



Two-wire pressure root non-slip

## ※CUSTOMIZABLE 可定制的



- The position where you can type logo

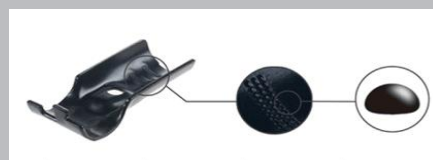

- Can be changed to:
  - 1.non-slip treatment, three rows of fine dots
  - 2.the non-slip dots

# METAL JOINT (SINGLE) 五金接头

METAL JOINT (SINGLE) 五金接头

## 28MM TUBE JOINT 28MM 管接头

W-1

COLOR: ● BK ● ZN ● CN ○ NI

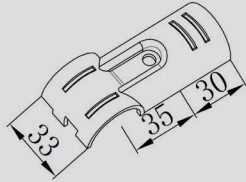

Weight:0.07kg  
Qty/box:300pcs

W-1A

COLOR: ● BK ● ZN ● CN ● NI

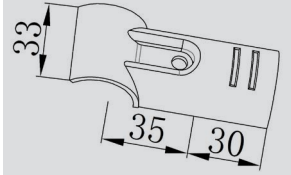

Weight:0.068kg  
Qty/box:300pcs

W-2

COLOR: ● BK ● ZN ● CN ● NI

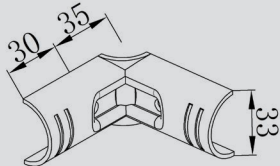

Weight:0.091kg  
Qty/box:200pcs

W-3

COLOR: ● BK ● ZN ● CN ● NI

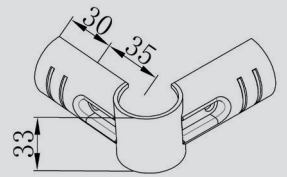

Weight:0.125kg  
Qty/box:100pcs

W-4

COLOR: ● BK ● ZN ● CN ● NI

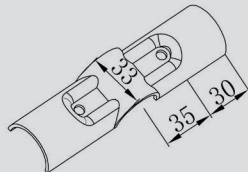

Weight:0.11kg  
Qty/box:200pcs

W-3H

COLOR: ● BK ● ZN ● CN ● NI

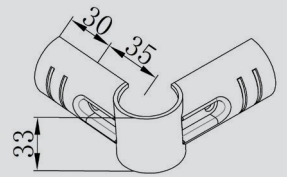

\* Can be fixed on the lean tube  
(可以夹在精益管上不滑落)

Weight:0.125kg  
Qty/box:100pcs

W-4A

COLOR: ● BK ● ZN ● CN ● NI

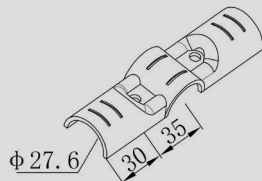

Weight:0.1kg  
Qty/box:200pcs

W-4B

COLOR: ● BK ● ZN ● CN ● NI

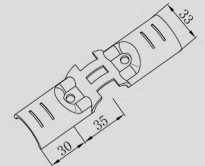

Weight:0.11kg  
Qty/box:200pcs

W-5

COLOR: ● BK ● ZN ● CN ● NI

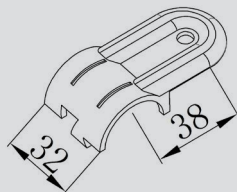

Weight:0.055kg  
Qty/box:300pcs

W-6

COLOR: ● BK ● ZN ● CN ○ NI

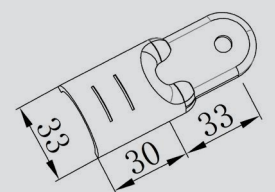

Weight:0.065kg  
Qty/box:300pcs



28MM TUBE JOINT 28MM 管接头

W-6A

COLOR: ● BK ● ZN ● CN ● NI

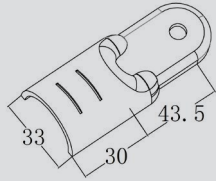

Weight:0.07kg  
Qty/box:300pcs

W-7

COLOR: ● BK ● ZN ● CN ● NI

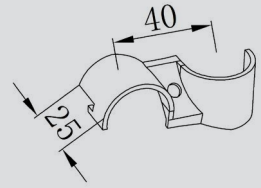

Weight:0.05kg  
Qty/box:200pcs

W-7A

COLOR: ● BK ● ZN ● CN ● NI

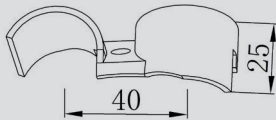

Weight:0.045kg  
Qty/box:300pcs

W-8-30

COLOR: ● BK ● ZN ● CN ● NI

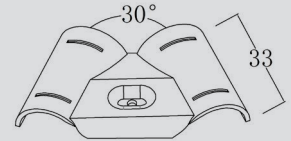

Weight:0.07kg  
Qty/box:200pcs

W-8-45

COLOR: ● BK ● ZN ● CN ● NI

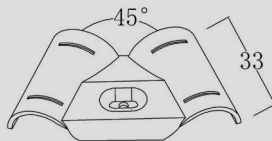

Weight:0.072kg  
Qty/box:150pcs

W-8-60

COLOR: ● BK ● ZN ● CN ● NI

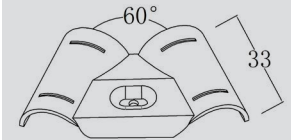

Weight:0.075kg  
Qty/box:150pcs

W-9

COLOR: ● BK ● ZN ● CN ● NI

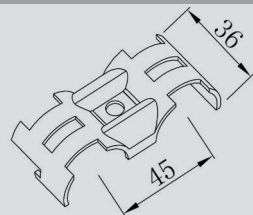

Weight:0.07kg  
Qty/box:200pcs

W-9A

COLOR: ● BK ● ZN ● CN ● NI

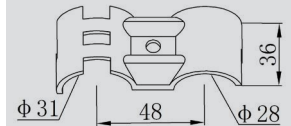

Weight:0.078kg  
Qty/box:200pcs

W-10A

COLOR: ● BK ● ZN ● CN ● NI

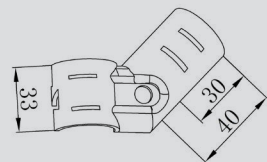

Weight:0.072kg  
Qty/box:200pcs

W-10B

COLOR: ● BK ● ZN ● CN ● NI

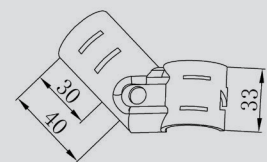

Weight:0.072kg  
Qty/box:200pcs

## 28MM TUBE JOINT 28MM 管接头

W-11-90

COLOR: ● BK ● ZN ● CN ● NI

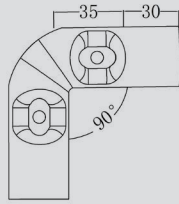

Weight:0.1kg  
Qty/box:150pcs

W-11-110

COLOR: ● BK ● ZN ● CN ● NI

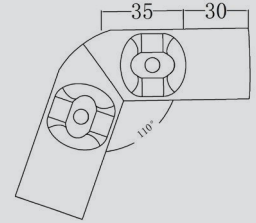

Weight:0.11kg  
Qty/box:150pcs

W-11-160

COLOR: ● BK ● ZN ● CN ● NI

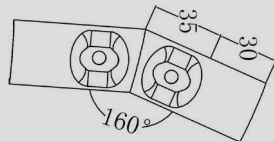

Weight:0.11kg  
Qty/box:150pcs

W-11-180

COLOR: ● BK ● ZN ● CN ● NI

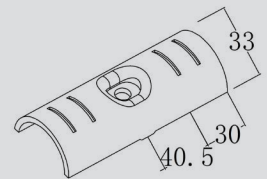

Weight:0.1kg  
Qty/box:200pcs

W-12

COLOR: ● BK ● ZN ● CN ● NI

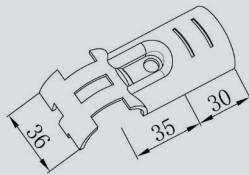

Weight:0.07kg  
Qty/box:200pcs

W-13

COLOR: ● BK ● ZN ● CN ● NI

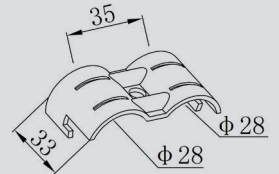

Weight:0.055kg  
Qty/box:300pcs

W-13A

COLOR: ● BK ● ZN ● CN ● NI

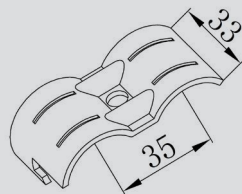

Weight:0.05kg  
Qty/box:300pcs

W-13B

COLOR: ● BK ● ZN ● CN ● NI

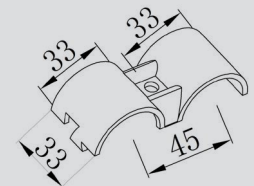

Weight:0.089kg  
Qty/box:200pcs

W-13C

COLOR: ● BK ● ZN ● CN ● NI

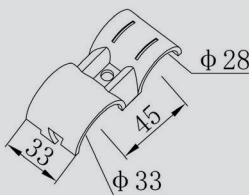

Weight:0.089kg  
Qty/box:200pcs

W-14

COLOR: ● BK ● ZN ● CN ● NI

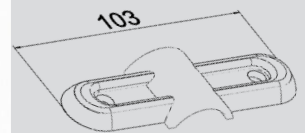

Weight:0.65kg  
Qty/box:200pcs

COLOR: ● BK ● ZN ● CN ● NI

28MM TUBE JOINT 28MM 管接头

W-15A

COLOR: ● BK ● ZN ● CN ● NI

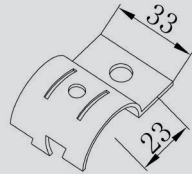

weight:0.045kg  
Qty/box:400pcs

W-15B

COLOR: ● BK ● ZN ● CN ● NI

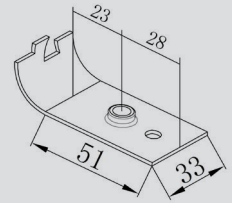

Weight:0.055kg  
Qty/box:400pcs

W-16

COLOR: ● BK ● ZN ● CN ● NI

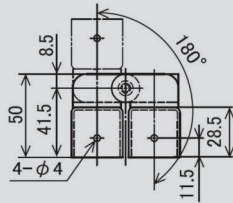

Weight:0.055kg  
Qty/box:400pcs

W-17

COLOR: ● BK ● ZN ● CN ● NI

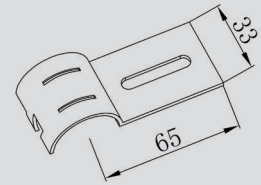

Weight:0.065kg  
Qty/box:300pcs

W-17A

COLOR: ● BK ● ZN ● CN ● NI

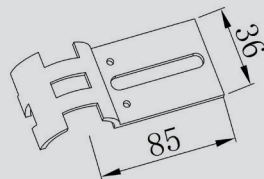

Weight:0.045kg  
Qty/box:200pcs

W-18A

COLOR: ● BK ● ZN ● CN ● NI

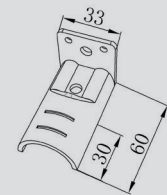

Weight:0.065kg  
Qty/box:150pcs

W-18B

COLOR: ● BK ● ZN ● CN ● NI

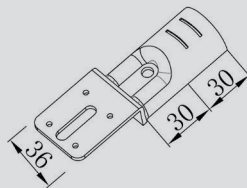

Weight:0.055kg  
Qty/box:200pcs

W-19

COLOR: ● BK ● ZN ● CN ● NI

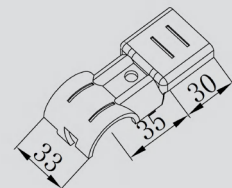

Weight:0.085kg  
Qty/box:200pcs

W-20

COLOR: ● BK ● ZN ● CN ● NI

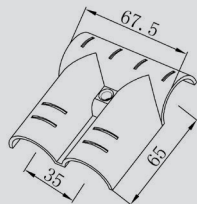

Weight:0.122kg  
Qty/box:150pcs

W-21

COLOR: ● BK ● ZN ● CN ● NI

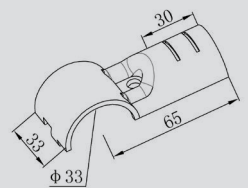

Weight:0.082kg  
Qty/box:300pcs



## 28MM TUBE JOINT 28MM 管接头

W-22A

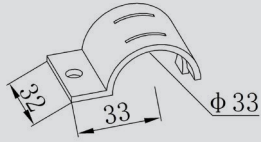

Weight:0.055kg  
Qty/box:300pcs

W-22B

COLOR: ● BK ● ZN ● CN ● NI

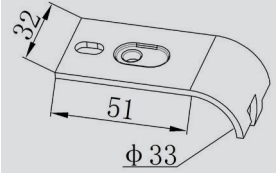

Weight:0.065kg  
Qty/box:300pcs

W-23

COLOR: ● BK ● ZN ● CN ● NI

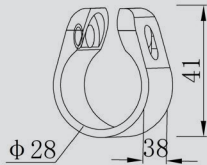

Weight:0.082kg  
Qty/box:200pcs

W-24

COLOR: ● BK ● ZN ● CN ● NI

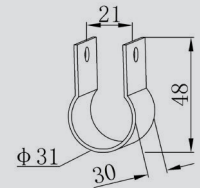

Weight:0.035kg  
Qty/box:300pcs

W-25

COLOR: ● BK ● ZN ● CN ● NI

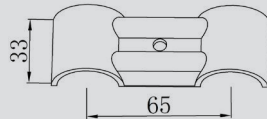

Weight:0.098kg  
Qty/box:300pcs



28MM TUBE JOINT 28MM 管接头

**WJ-1** COLOR: ● BK ● ZN ● CN ● NI

W-1:2 pcs  
M6\*25:1 set

**WJ-1A** COLOR: ● BK ● ZN ● CN ● NI

W-1A:2 pcs  
M6\*25:1 set

**WJ-2** COLOR: ● BK ● ZN ● CN ● NI

W-2:1 pcs W-3:1 pcs  
M6\*25:2set

**WJ-3** COLOR: ● BK ● ZN ● CN ● NI

W-2:2pcs W-4:1 pcs  
M6\*25:3set

**WJ-4** COLOR: ● BK ● ZN ● CN ● NI

W-4:2 pcs  
M6\*25:2set

**WJ-5** COLOR: ● BK ● ZN ● CN ● NI

W-2:4pcs  
M6\*25:4 set

**WJ-6** COLOR: ● BK ● ZN ● CN ● NI

W-7:2 pcs  
M6\*25:1set

**WJ-6A** COLOR: ● BK ● ZN ● CN ● NI

W-7A:2pcs  
M6\*25:1set

**WJ-7** COLOR: ● BK ● ZN ● CN ● NI

W-5:2pcs W-6:2pcs  
M6\*28:2set

**WJ-7A** COLOR: ● BK ● ZN ● CN ● NI

W-6A:4pcs  
M6\*28:2set



# METAL JOINT (SET) 五金接头

METAL JOINT (SET) 五金接头

## 28MM TUBE JOINT 28MM 管接头

WJ-8

COLOR: ● BK ● ZN ● CN ● NI

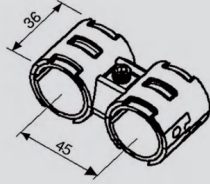
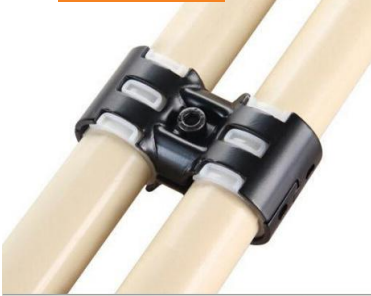

W-9:2pcs WJP-6:2pcs  
M6\*25:1set

WJ-9

COLOR: ● BK ● ZN ● CN ● NI

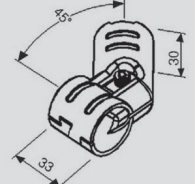

W-10A:1pcs W-10B:1pcs  
M6\*25:1set

WJ-10

COLOR: ● BK ● ZN ● CN ● NI

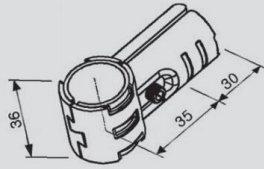
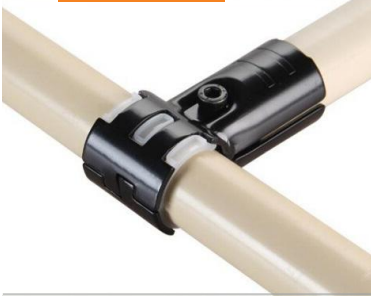

W-12:2pcs WJP-6:1pcs  
M6\*25:1set

WJ-11

COLOR: ● BK ● ZN ● CN ● NI

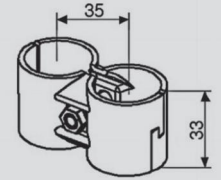

W-13:2pcs  
M6\*25:1set

WJ-11A

COLOR: ● BK ● ZN ● CN ● NI

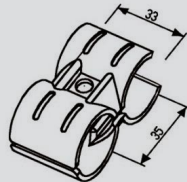
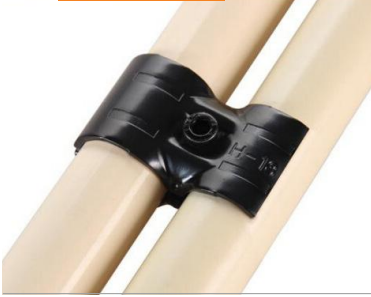

W-13A:2pcs  
M6\*25:1set

WJ-12

COLOR: ● BK ● ZN ● CN ● NI

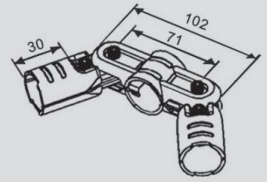
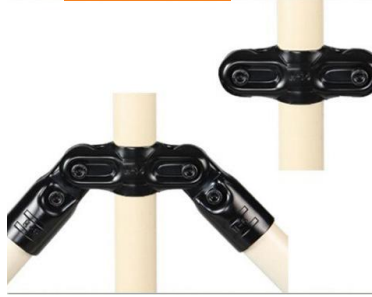

W-6:4 pcs W-14:2pcs  
M6\*25:4set

WJ-13

COLOR: ● BK ● ZN ● CN ● NI

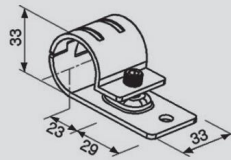
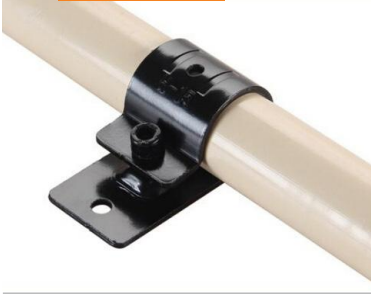

W-15A:1pcs W-15B:1pcs  
M6\*12:1set

WJ-14-30

COLOR: ● BK ● ZN ● CN ● NI

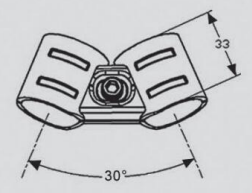
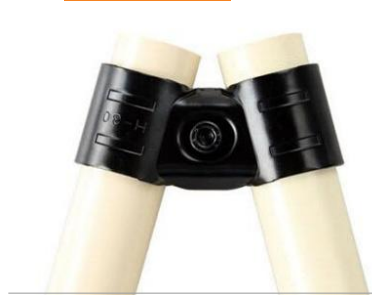

W-8-30:2pcs  
M6\*25:1set

WJ-14-45

COLOR: ● BK ● ZN ● CN ● NI

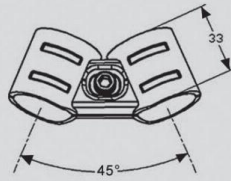

W-8-45:2pcs  
M6\*25:1set

WJ-14-60

COLOR: ● BK ● ZN ● CN ● NI

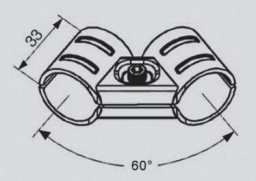

W-8-60:2pcs  
M6\*25:1set

28MM TUBE JOINT 28MM 管接头

WJ-15

COLOR: ● BK ● ZN ● CN ● NI

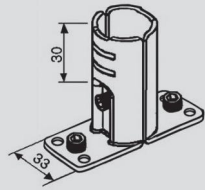

W-18A:2pcs  
M6\*25:1set

WJ-15A

COLOR: ● BK ● ZN ● CN ● NI

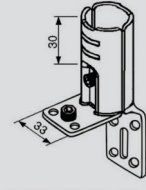

W-18A:1 pcs W-18B:1pcs  
M6\*25:1set

WJ-16-90

COLOR: ● BK ● ZN ● CN ● NI

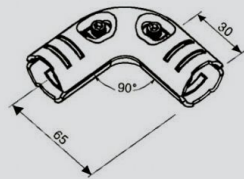

W-11-90:2pcs  
M6\*25:2set

WJ-16-110

COLOR: ● BK ● ZN ● CN ● NI

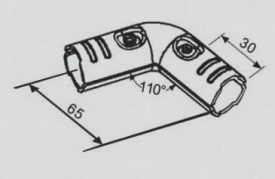

W-11-110:2 pcs  
M6\*25:2set

WJ-16-160

COLOR: ● BK ● ZN ● CN ● NI

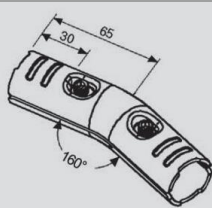
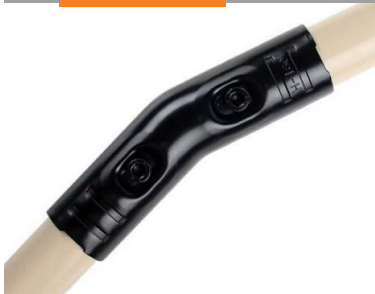

W-11-160:2pcs  
M6\*25:2set

WJ-16-180

COLOR: ● BK ● ZN ● CN ● NI

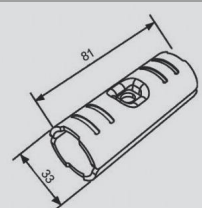

W-11-180:2pcs  
M6\*25:1set

WJ-17

COLOR: ● BK ● ZN ● CN ● NI

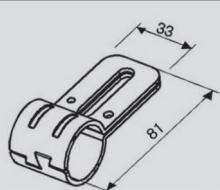

W-17:2pcs  
M6\*25:1set

WJ-18

COLOR: ● BK ● ZN ● CN ● NI

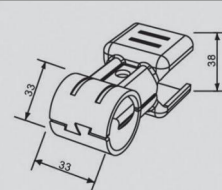

W-19:2pcs  
M6\*25:1set

WJ-18A

COLOR: ● BK ● ZN ● CN ● NI

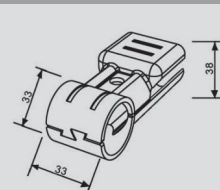

W-19:1pcs W-1:1pcs  
M6\*25:1set

WJ-19

COLOR: ● BK ● ZN ● CN ● NI

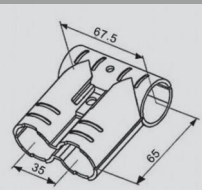
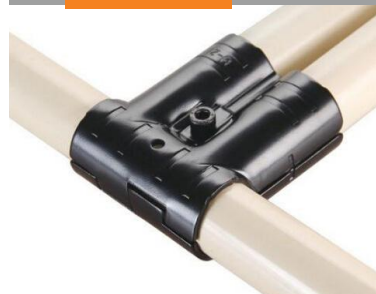

W-20:2pcs  
M6\*25:1set



# METAL JOINT (SET) 五金接头

METAL JOINT (SET) 五金接头

## 28MM TUBE JOINT 28MM 管接头

WJ-20

COLOR: ● BK ● ZN ● CN ● NI

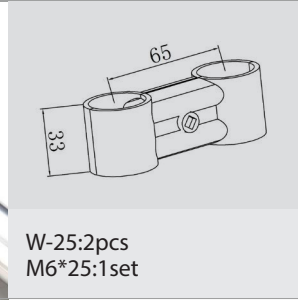
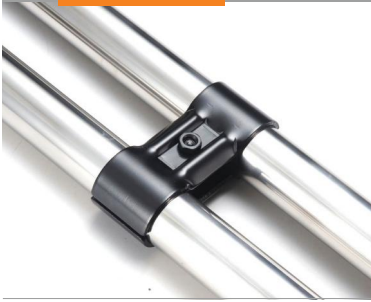

W-25:2pcs  
M6\*25:1set

WJ-21

COLOR: ● BK ● ZN ● CN ● NI

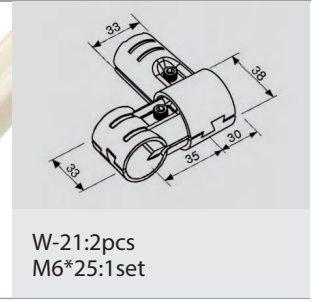
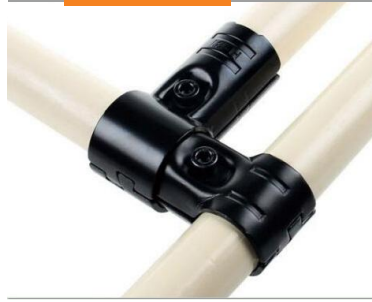

W-21:2pcs  
M6\*25:1set

WJ-22

COLOR: ● BK ● ZN ● CN ● NI

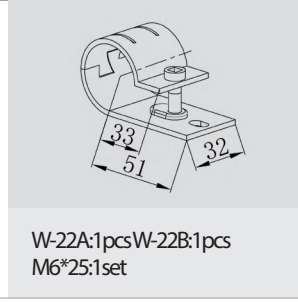

W-22A:1pcs W-22B:1pcs  
M6\*25:1set

WJ-23

COLOR: ● BK ● ZN ● CN ● NI



W-9A:2 pcs WJP-12:1pcs  
M6\*25:1

WJ-24

COLOR: ● BK ● ZN ● CN ● NI

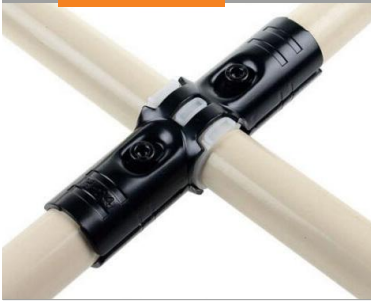

W-4B:2pcs WJP-12:1pcs  
M6\*25:2set

WJ-25

COLOR: ● BK ● ZN ● CN ● NI

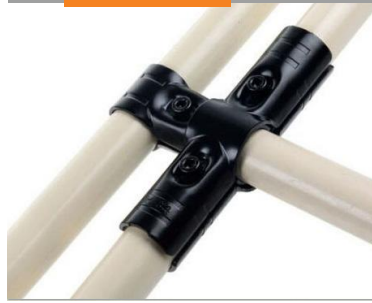

W-4A:2pcs  
M6\*25:2set

WJ-26

COLOR: ● BK ● ZN ● CN ● NI



W-13B:2set  
M6\*25:1set

WJ-27

COLOR: ● BK ● ZN ● CN ● NI

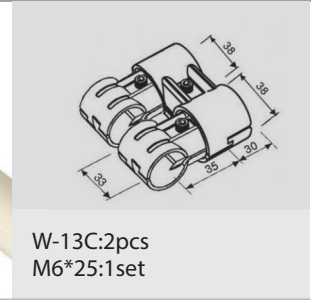

W-13C:2pcs  
M6\*25:1set



## DETAILED DESCRIPTION OF COATED PIPE $\Phi=28.6\text{MM}$ 28.3&28.6MM 复合管详细说明

NAMED OF PRODUCT  
品名

STANDARD COLOR OF COATED PIPE  
复合管标准颜色



	IV:Ivory
	WH:White
	SB:Sky Blue
	DB:Dark Blue
	RE:Red
	GR:Green
	YE:Yellow
	BE:Beige
	LG:Light Gray
	DG:Dark Gray
	BK:Black
	EBK: ESD Black
	ESD GRAY
	ESD IVORY

※T=THICKNESS 厚度

07=T0.7

08=T0.8

10=T1.0

12=T1.2

15=T1.5

20=T2.0

※LENGTH 长度

- customizable

※CUSTOMIZABLE 可定制的

- color, we can do it according customer sample, The MOQ is 1000PCS



※ 

- means accept any quantity

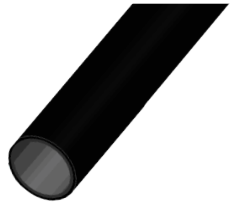

# COATED PIPE 复合管

## COATED PIPE(28.3MM) 28.3mm 复合管

Part Number	Dimension	Weight	Capacity	MOQ	Classification	Standard Length	Color	Photo
	(mm)	(g/meter)	(kg/m)	(pcs)		(mm)		
CP-2907	Φ28.3*0.7	495	40	◎	Coated Pipe	4000	IV WH SB DB RE GR YE BE LG BK	
CP-2910	Φ28.3*1.0	680	85	◎				
CP-2912	Φ28.3*1.2	785	105	500				
CP-2920	Φ28.3*2.0	1200	185	500				
CP-2907ESD	Φ28.3*0.7	505	45	◎	Coated Pipe	4000	EBK ESD Gray	
CP-2910ESD	Φ28.3*1.0	700	100	◎				
CP-2912ESD	Φ28.3*1.2	800	120	500				
CP-2920ESD	Φ28.3*2.0	1300	200	500				
PCP-2910	Φ28.3*1.0	600		◎	Powder Coated Pipe (PCP)	4000	Any colour	
PCP-2920	Φ28.3*2.0	1200		◎				
SPS-2907	Φ28.3*0.7	500	40	500	SUS439 SUS201 SUS304	4000	sliver	
SPS-2910	Φ28.3*1.0	670	90	500				
SPS-2912	Φ28.3*1.2	780	110	750				







COATED PIPE(28.6MM) 28.6mm 复合管

Part Number	Dimension	Weight	Capacity	MOQ	Classification	Standard Length	Color	Photo
	(mm)	(g/meter)	(kg/m)	(pcs)		(mm)		
CP-3007	Φ28.6*0.7	505	45	◎	Coated Pipe	4000	IV WH SB DB RE GR YE BE LG BK	
CP-3010	Φ28.6*1.0	700	100	◎				
CP-3012	Φ28.6*1.2	800	120	500				
CP-3020	Φ28.6*2.0	1300	200	500				
CP-3007ESD	Φ28.6*0.7	505	45	◎	Coated Pipe	4000	EBK ESD Gray	
CP-3010ESD	Φ28.6*1.0	700	100	◎				
CP-3012ESD	Φ28.6*1.2	800	120	500				
CP-3020ESD	Φ28.6*2.0	1300	200	500				
PCP-3010	Φ28.6*1.0	600		◎	Powder Coated Pipe (PCP)	4000	Any colour	
PCP-3020	Φ28.6*2.0	1200		◎				
SPS-3007	Φ28.6*0.7	500	40	500	SUS439 SUS201 SUS304	4000	sliver	
SPS-3010	Φ28.6*1.0	670	90	500				
SPS-3012	Φ28.6*1.2	780	110	750				







# COATED PIPE 复合管

## FEATURES OF D-COAT PIPE

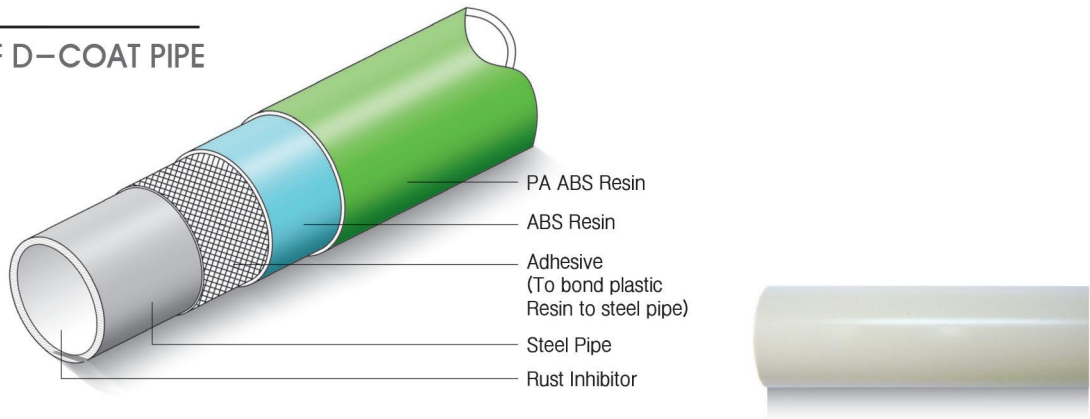

1. Steel pipe is coated with ABS. Then, the surface is coated again with the new material of PA ABS.
2. Compared to the conventional ABS coating pipe, D-Coat Pipe is outstanding in oil resistance and chemical resistance. In particular, salinity, rust preventative oil or cutting oil does not cause cracks or discoloration of the pipe.
3. This product comes in a variety of colors for use in various items or per company's image.
4. With outstanding durability, this pipe is easily processed. Rustproof coating inside the pipe provides superior corrosion resistance.

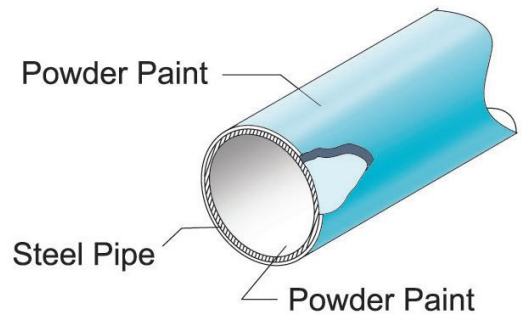
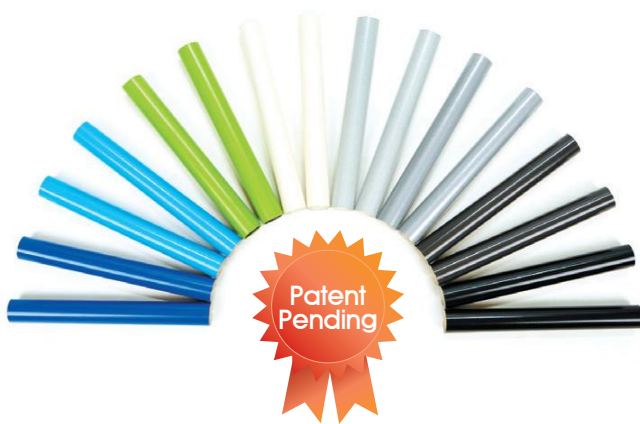

### 1. Environmental

- ECO-pipe is fully recyclable.
- Powder painted steel pipe of internal and external surface

### 2. Economical

- 20% less than coated pipe
- 35% less than ESD coated pipe
- 30% less than stainless steel pipe

### 3. Colorful

- Wider selection of colors and textures.

### 4. Chemical resistant

- High resistant to oil, UV light, and corrosion.

### 5. Non-flammable

- No emission of toxic fumes in fire.

### 6. Electrolytic Corrosion Free

- Free of Electrolytic Corrosion.



## THE ADVANTAGES OF STAINLESS PIPE

- 1. Environmental**
  - Stainless pipe which is 100% recycable
- 2. High Strength & Durability**
  - Surface resistant to light abrasion or contact with metal tools
- 3. High Oil & Chemical Resistance**
  - High resistance to oil, solvents, bleaches, etc.
- 4. Non-Flammable**
  - Inherently non-flammable.
- 5. Conductive**
  - Inherently conductive



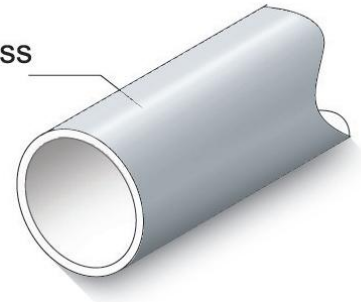

Stainless Pipe



# METAL JOINTS 金属接头 28.6



## ※COLOR 颜色

	Black	BK
	Zinc	ZN
	Chrome	CN
	Nickel	NI

## ※MATERIAL 材料

- SPCC、SUS 304

## ※THICKNESS 厚度

- 2.5mm

## ※PRODUCT DETAILS 产品细节

can be punched  
and fixed



Innovated Joint with  
Assembly help line



the side pressing line of the hardware



Two-wire pressure root non-slip

## ※CUSTOMIZABLE 可定制的



- The position  
where you can type logo



28.6MM TUBE JOINT 28.6MM 管接头

MATERIAL:SPCC

METAL JOINT(SINGLE) 五金接头

**L-1** COLOR: ● BK ● ZN ● CN ● NI

28.6

Weight:0.07kg  
Qty/box:300pcs

**L-2** COLOR: ● BK ● ZN ● CN ● NI

28.6

Weight:0.07kg  
Qty/box:300pcs

**L-3** COLOR: ● BK ● ZN ● CN ● NI

28.6

Weight:0.07kg  
Qty/box:300pcs

**L-4** COLOR: ● BK ● ZN ● CN ● NI

28.6

Weight:0.07kg  
Qty/box:300pcs

**S-1** COLOR: ● BK ● ZN ● CN ● NI

28.6

Weight:0.07kg  
Qty/box:300pcs

**S-2** COLOR: ● BK ● ZN ● CN ● NI

28.6

Weight:0.091kg  
Qty/box:200pcs

**S-3** COLOR: ● BK ● ZN ● CN ● NI

28.6

Weight:0.125kg  
Qty/box:100pcs

**S-4** COLOR: ● BK ● ZN ● CN ● NI

28.6

Weight:0.11kg  
Qty/box:200pcs

**S-5** COLOR: ● BK ● ZN ● CN ● NI

28.6

Weight:0.07kg  
Qty/box:300pcs

**S-6** COLOR: ● BK ● ZN ● CN ● NI

28.6

Weight:0.07kg  
Qty/box:300pcs



# METAL JOINT (SINGLE) 五金接头

28.3&28.6MM TUBE JOINT 28.3&28.6MM 管接头 MATERIAL:SPCC

METAL JOINT (SINGLE) 五金接头

**S-7** COLOR: ● BK ● ZN ● CN ● NI

28.6

Weight:0.07kg  
Qty/box:300pcs

**S-8-45** COLOR: ● BK ● ZN ● CN ● NI

28.6

Weight:0.07kg  
Qty/box:300pcs

**S-9** COLOR: ● BK ● ZN ● CN ● NI

28.6

Weight:0.07kg  
Qty/box:300pcs

**S-10A** COLOR: ● BK ● ZN ● CN ● NI

28.6

Weight:0.07kg  
Qty/box:300pcs

**S-10B** COLOR: ● BK ● ZN ● CN ● NI

28.6

Weight:0.07kg  
Qty/box:300pcs

**S-11-90** COLOR: ● BK ● ZN ● CN ● NI

28.6

Weight:0.07kg  
Qty/box:300pcs

**S-13** COLOR: ● BK ● ZN ● CN ● NI

28.6

Weight:0.07kg  
Qty/box:300pcs

**S-14** COLOR: ● BK ● ZN ● CN ● NI

28.6

Weight:0.07kg  
Qty/box:300pcs

**S-15A** COLOR: ● BK ● ZN ● CN ● NI

28.6

Weight:0.07kg  
Qty/box:300pcs

**S-15B** COLOR: ● BK ● ZN ● CN ● NI

28.6

Weight:0.07kg  
Qty/box:300pcs

S-17

COLOR: ● BK ● ZN ● CN ● NI

28.6

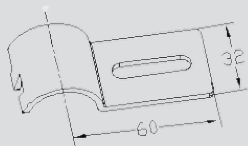

Weight:0.07kg  
Qty/box:300pcs

PLASTIC JOINT  
塑胶接头



# PLASTIC JOINT 塑性接头

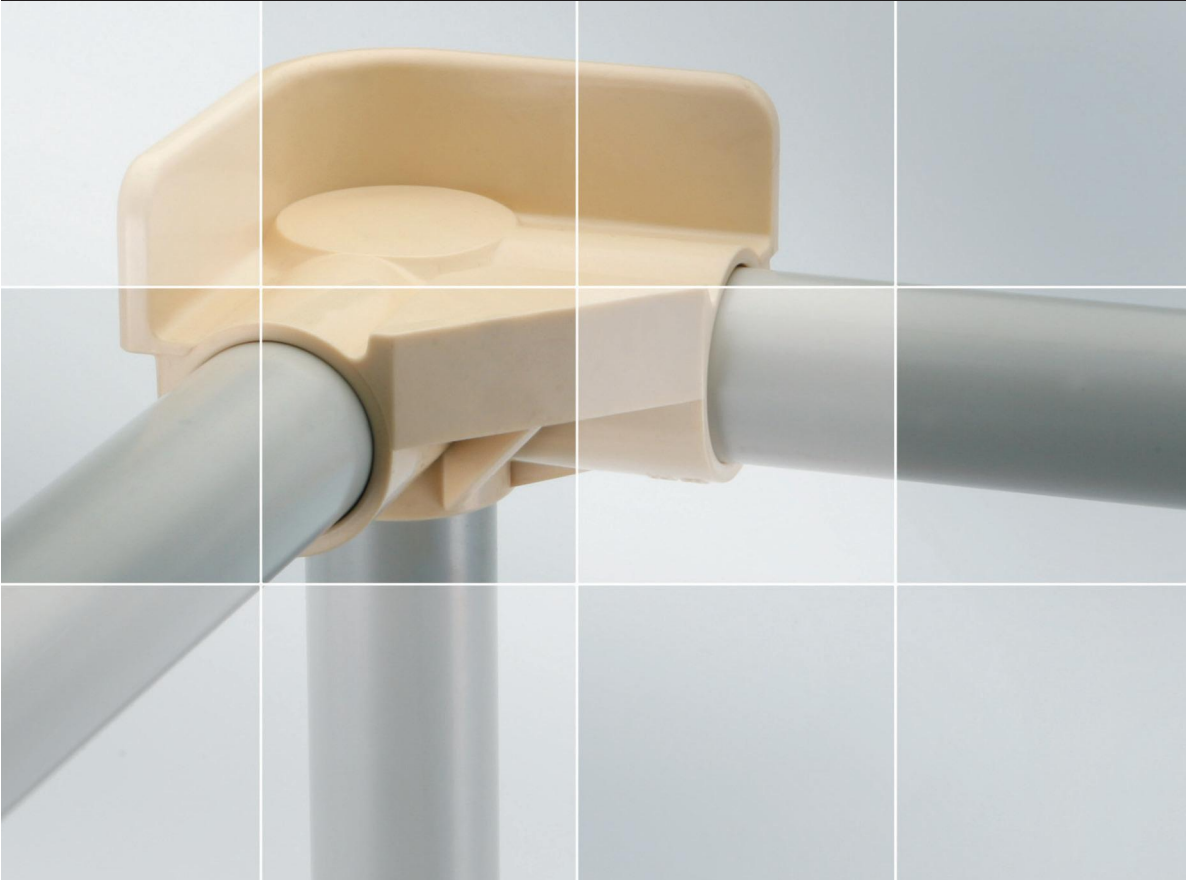

COLOR  
颜色

	IV:Ivory
	BK:Black
	EBK: ESD Black

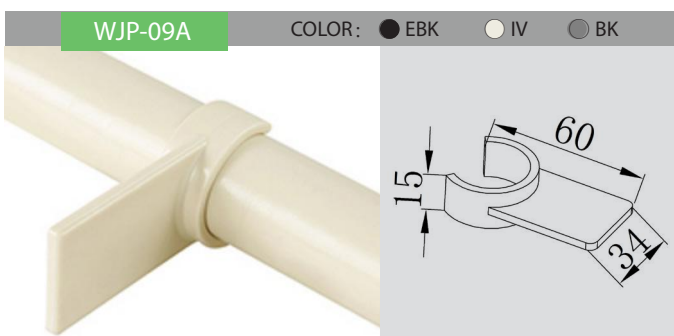
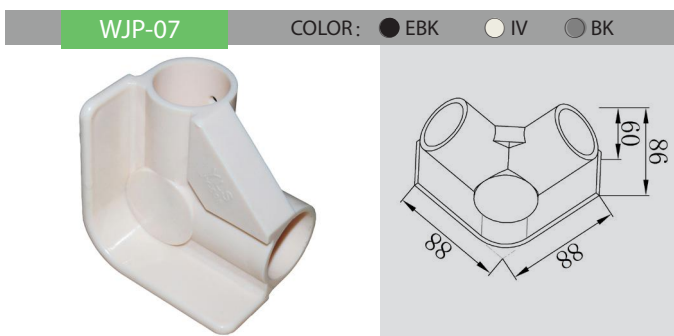
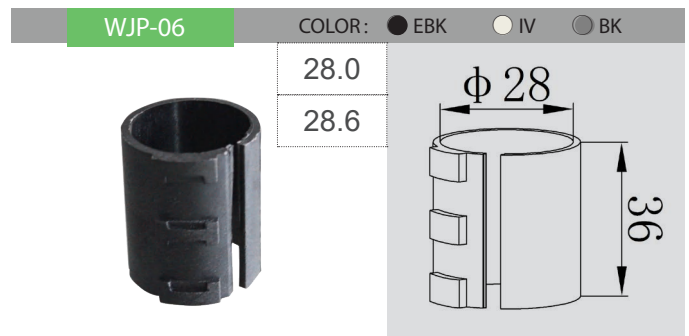
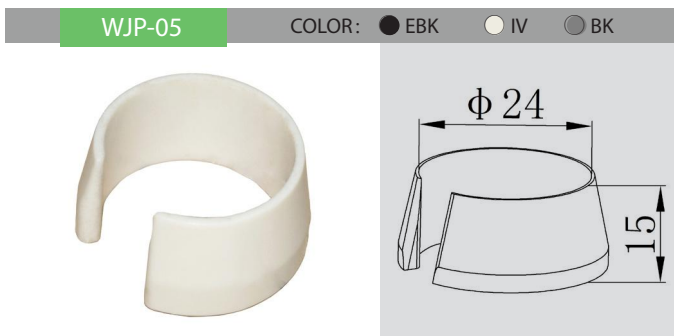
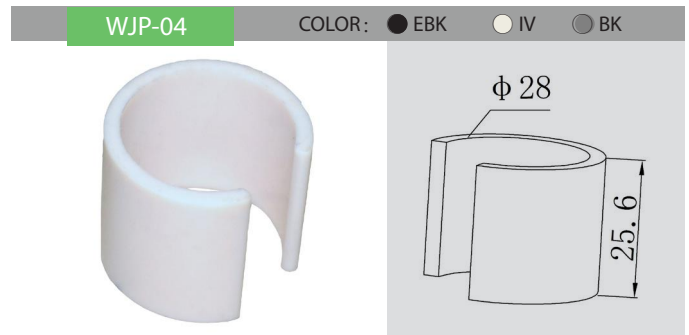
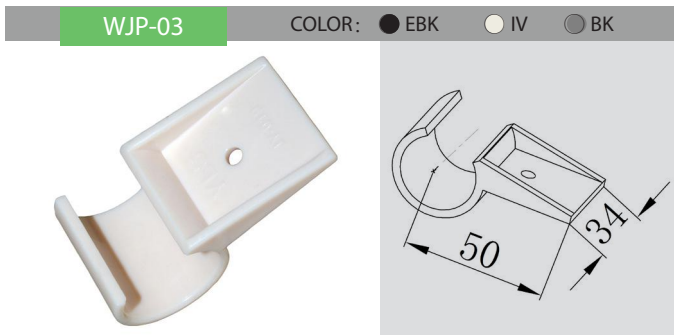
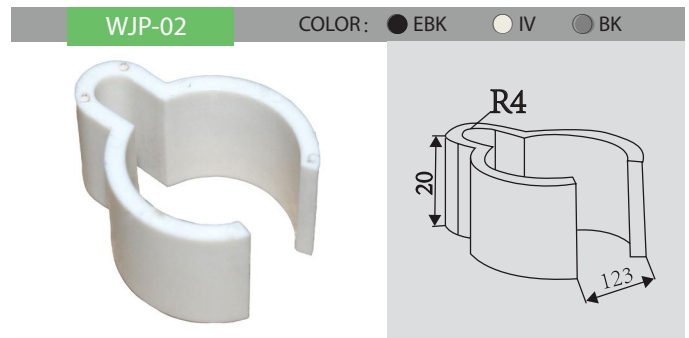
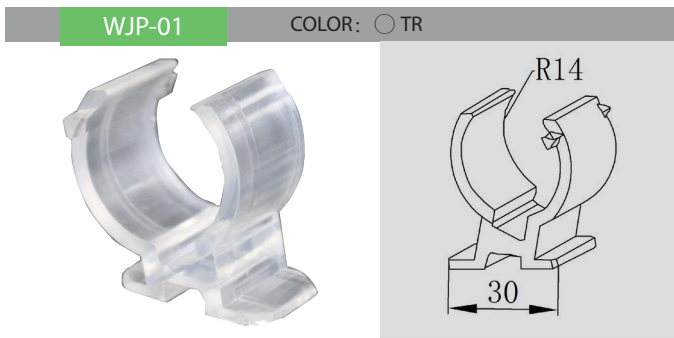



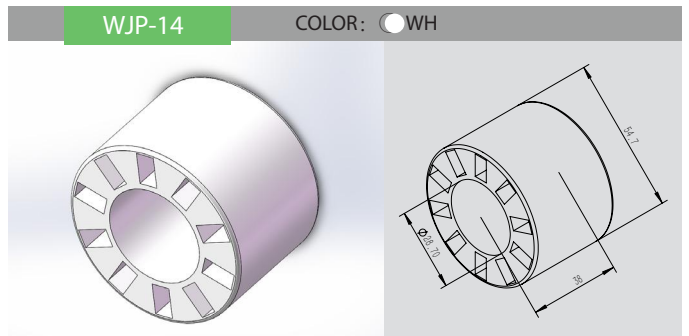
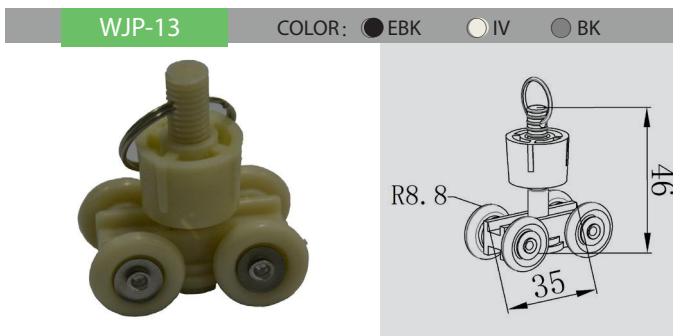
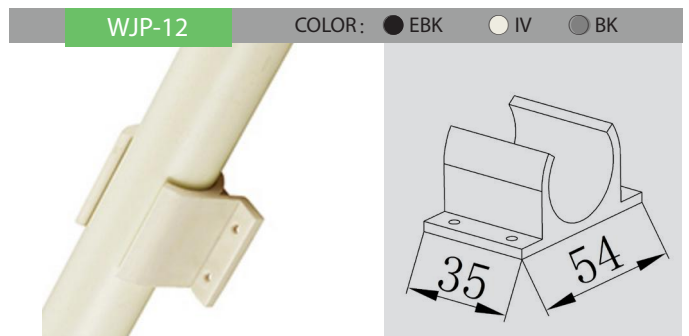
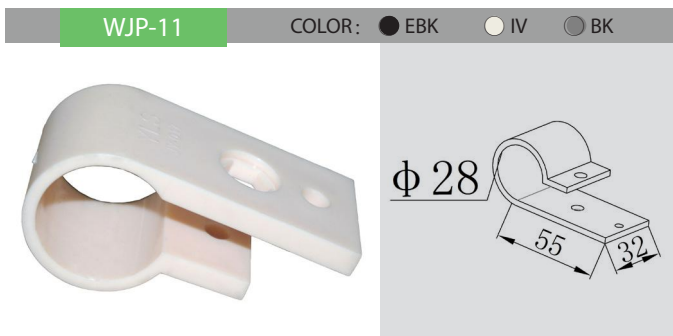
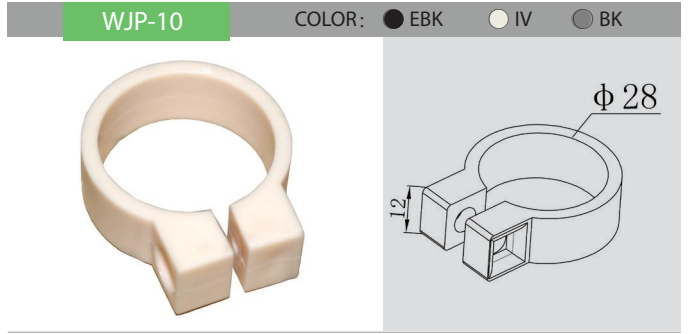
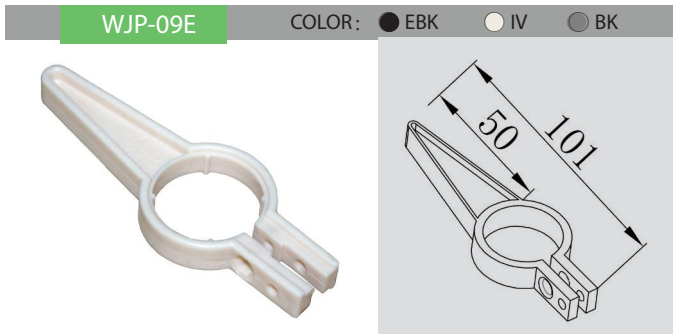
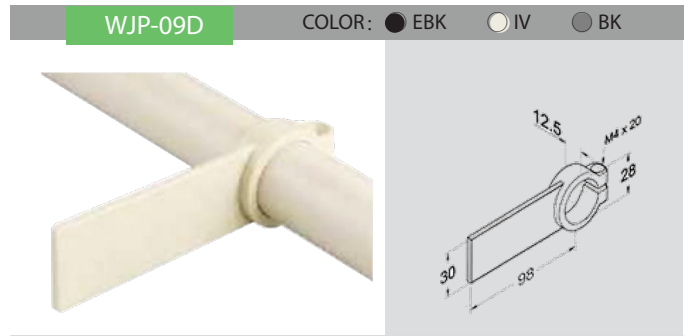
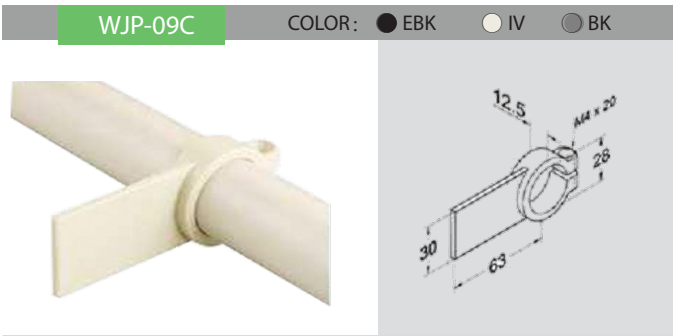

WJP-17

COLOR: ● BK ○ WH



WJP-18

COLOR: ● BK ○ WH



WJP-19

COLOR: ○ WH

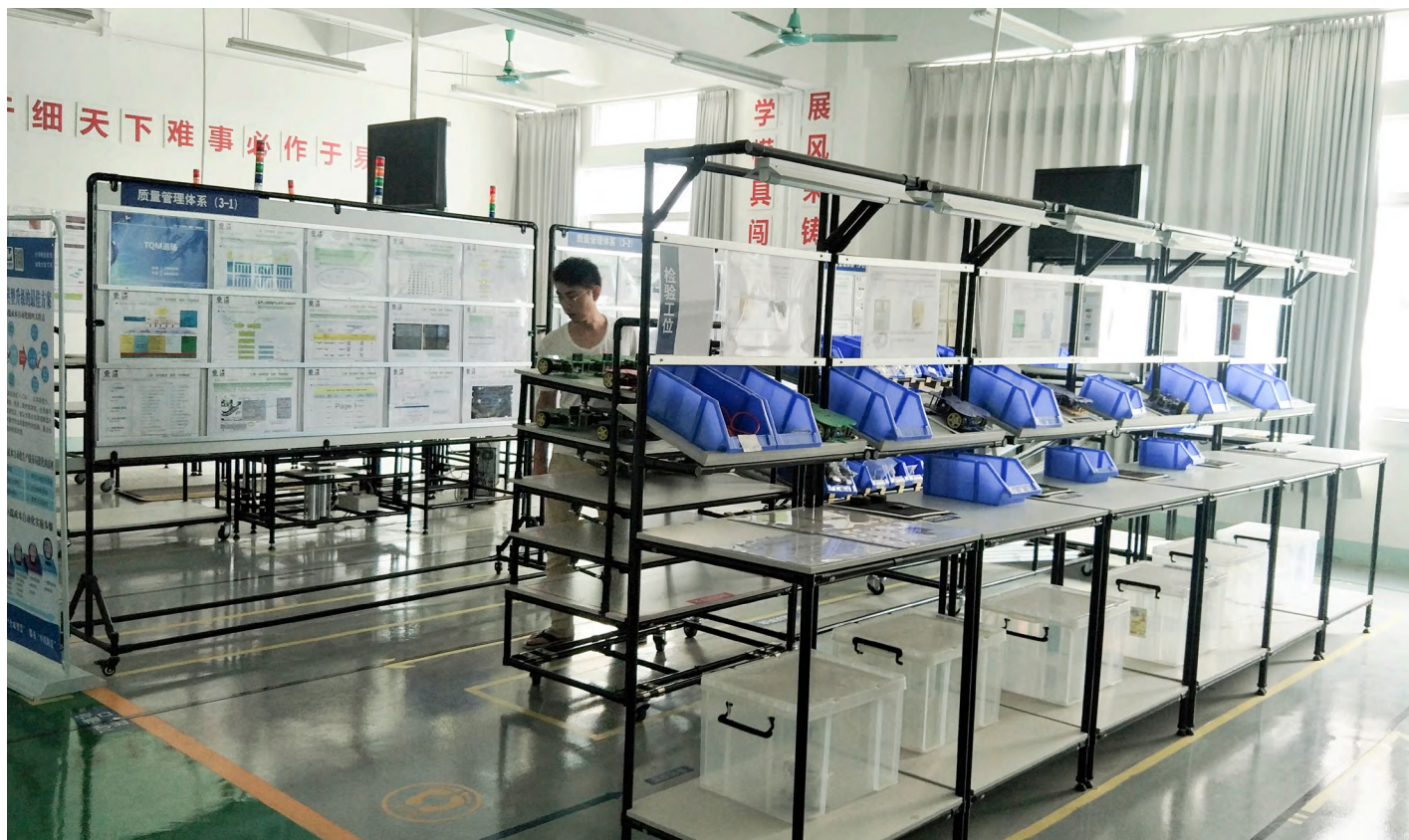
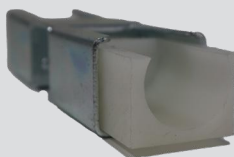



# ROLLER TRACKS 滑轨



## SERIES 系列

35 series

40 series

60 series

72 series

85 series

### ※COLOR 颜色

	white	WH
	black	BK
	esd black	EBK
	yellow	YE
	gray	GR

### ※LENGTH 长度

4000mm  
Other lengths can also be customized,  
MOQ=1000pcs

### ※WHEEL TYPE 轮子种类



TAPER TYPE  
鼓轮

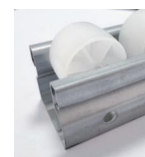

FLAT TYPE  
平轮

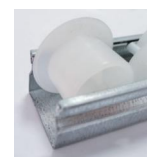

FLANGE TYPE  
挡边轮

### ※MATERIAL 材质

steel 铁  
aluminum 铝材质



## STEEL ROLLER TRACKS 铁滑轨

Series 系列	Item No. 产品名	Main frame material 主框架 材料	High (mm) 总高	slot High (mm) 槽高	Groove width (mm) 槽宽	Roller Diameter (mm) 轮径	Wheel width (mm) 轮宽	wheels distance (mm) 轮距	Roller Pitch (mm) 销钉 直径	weight kg/m 每米 重量	standard length (m) 标准 长度
35 Series	RTS-35A	steel	35	26.5	35	31	24	34	3	0.78	4
40 series	RTS-40A	steel	43	32	40	31	21.5	36	4	1.1	4
	RTS-40B	steel	43	32	40	31	21.5	36	4	1.07	4
	RTS-40C	steel	44	32	40	33.5	24	37	4	1.17	4
	RTS-40D	steel	44	32	40	33.5	24	37	4	1.15	4
	RTS-47A	steel	52	32	40	49	25	50	4	1.1	4
	RTS-48A	steel	44.5	32	40	34	26.5	25	4	1.2	4
	RTS-48B	steel	49	32	40	43	24	50	4	4.5	4
	RTS-48C	steel	53	33	40	51	17	67	4	1.4	4
60 Series	RTS-60A	steel	27	25	60	15	42	17	4	1.2	4
	RTS-60B	steel	35	33	60	30	42	37	5	1.35	4
85 Series	RTS-85A	steel	49	34	85	43	53	49	5	2.3	4
	RTS-85B	steel	44	33	85	34	68.5	25	5	3.3	4

## ALUMINUM ROLLER TRACKS 铝滑轨

Series 系列	Item No. 产品名	Main frame material 主 框架 材料	High (mm) 总高	slot High (mm) 槽高	Groove width (mm) 槽宽	Roller Diameter (mm) 轮径	Wheel width (mm) 轮宽	wheels distance (mm) 轮距	Roller Pitch (mm) 销钉 直径	weight kg/m 每米 重量	standard length(m) 标准 长度
40 series	RTA-40A	Aluminum	42.5	35	40	33	20	41	4	0.7	4
	RTA-40B	Aluminum	38.5	35	40	28	28	45.5	4	0.75	4
	RTA-40C	Aluminum	51	35	40	33	20	41	4	0.8	4
	RTA-47A	Aluminum	42.5	35	40	33	20	41	4	0.8	4
	RTA-47B	Aluminum	38.5	35	40	28	22	45.5	4	0.6	4
60 series	RTA-60	Aluminum	42	35	60	30	44	41	4	1.22	4
72 series	RTA-72	Aluminum	42	35	72	34	54	45	5	1.25	4
85 series	RTA-85	Aluminum	42	35	85	38	64	49	5	1.56	4

# ROLLER PLACON 滑轨

ROLLER PLACON 滑轨

## STEEL ROLLER PLACON 铁滑轨

RTS-35A

COLOR: ● WH ● YE ● ESK ○ GR

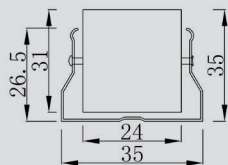

L.W:4000mm.35mm  
Weight:0.78kg/m

RTS-40A (taper type)

COLOR: ● WH ● YE ● ESK ○ GR

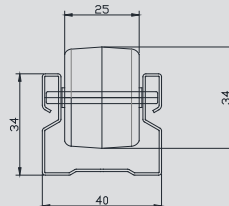

L.W:4000mm.40mm  
Weight:1.1kg/m

RTS-40B (flat type)

COLOR: ● WH ● YE ● ESK ○ GR

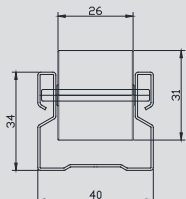

L.W:4000mm.40mm  
Weight:1.1kg/m

RTS-40C

COLOR: ● WH ● YE ● ESK ○ GR

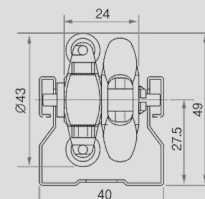

L.W:4000mm.40mm  
Weight:1.5kg/m

RTS-40D

COLOR: ● WH ● YE ● ESK ○ GR

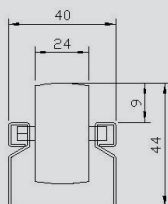

L.W:4000mm.40mm  
Weight:1.23kg/m

RTS-47A

COLOR: ● WH ● YE ● ESK ○ GR

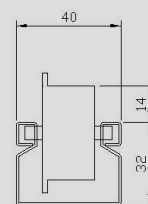

L.W:4000mm.40mm  
Weight:1.32kg/m

RTS-48A

COLOR: ● WH ● YE ● ESK ○ GR

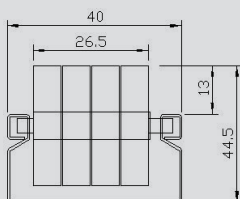
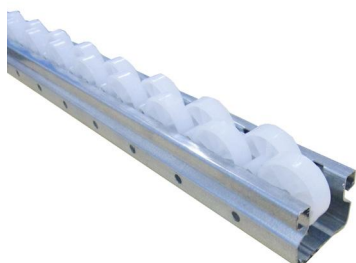

L.W:4000mm.40mm  
Weight:1.36kg/m

RTS-48B

COLOR: ● WH ● YE ● ESK ○ GR

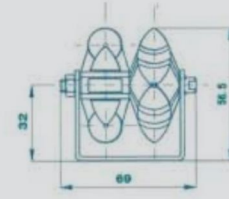
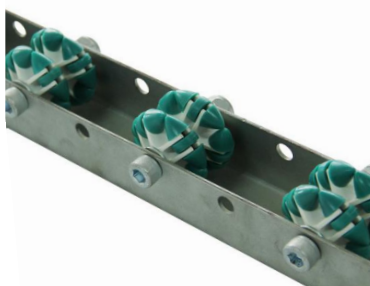

L.W:4000mm.35mm  
Weight:0.78kg/m

RTS-48C

COLOR: ● WH ● YE ● ESK ○ GR

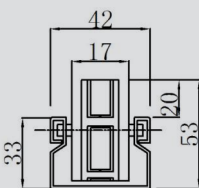

L:1000mm  
Weight:1.4kg/m

RTS-60A

COLOR: ● WH ● YE ● ESK ○ GR

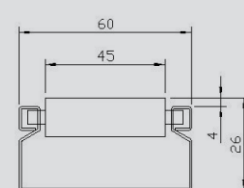

L.W:4000mm.60mm  
Weight:1.35kg/m

## STEEL ROLLER PLACON 铁滑轨

RTS-60B

COLOR: ● WH ● YE ● ESK ○ GR

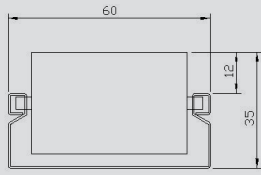

L.W:4000mm.60mm  
Weight:1.42kg/m

RTS-85A

COLOR: ● WH ● YE ● ESK ○ GR

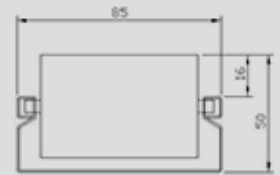
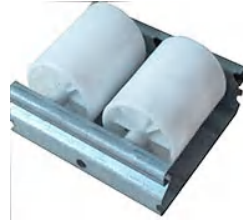

L.W:4000mm.85mm  
Weight:1.5kg/m

RTS-85B

COLOR: ● WH ● YE ● ESK ○ GR

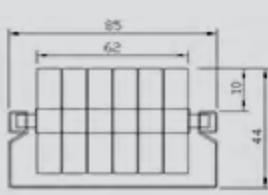

L.W:4000mm.85mm  
Weight:1.8kg/m

ROLLER PLACON 滑轨





## ALUMINUM ROLLER PLACON 铝滑轨

RTA-40A

COLOR: ● WH ● YE ● ESK ○ GR

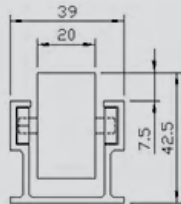

L.W:4000mm.40mm  
Weight:0.5kg/m

RTA-40B

COLOR: ● WH ● YE ● ESK ○ GR

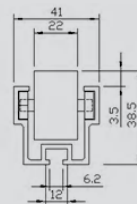

L.W:4000mm.40mm  
Weight:0.5kg/m

RTA-40C

COLOR: ● WH ● YE ● ESK ○ GR

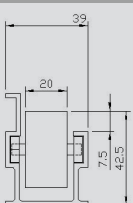

L.W:4000mm.40mm  
Weight:0.8kg/m

RTA-47A

COLOR: ● WH ● YE ● ESK ○ GR

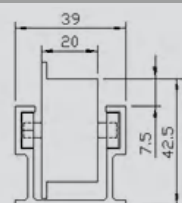

L.W:4000mm.40mm  
Weight:0.8kg/m

RTA-47B

COLOR: ● WH ● YE ● ESK ○ GR

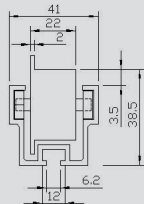

L.W:4000mm.40mm  
Weight:0.6kg/m

RTA-60A

COLOR: ● WH ● YE ● ESK ○ GR

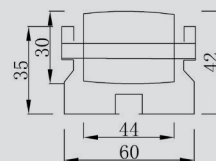

L.W:4000mm.60mm  
Weight:1.22kg/m

RTA-72A

COLOR: ● WH ● YE ● ESK ○ GR

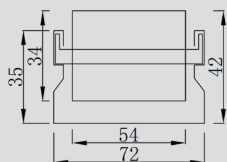

L.W:4000mm.72mm  
Weight:1.25kg/m

RTA-85A

COLOR: ● WH ● YE ● ESK ○ GR

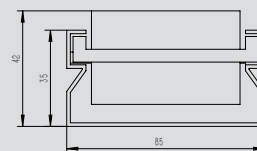

L.W:4000mm.85mm  
Weight:1.65kg/m

# MOUNTING BRACKETS 滑轨接头

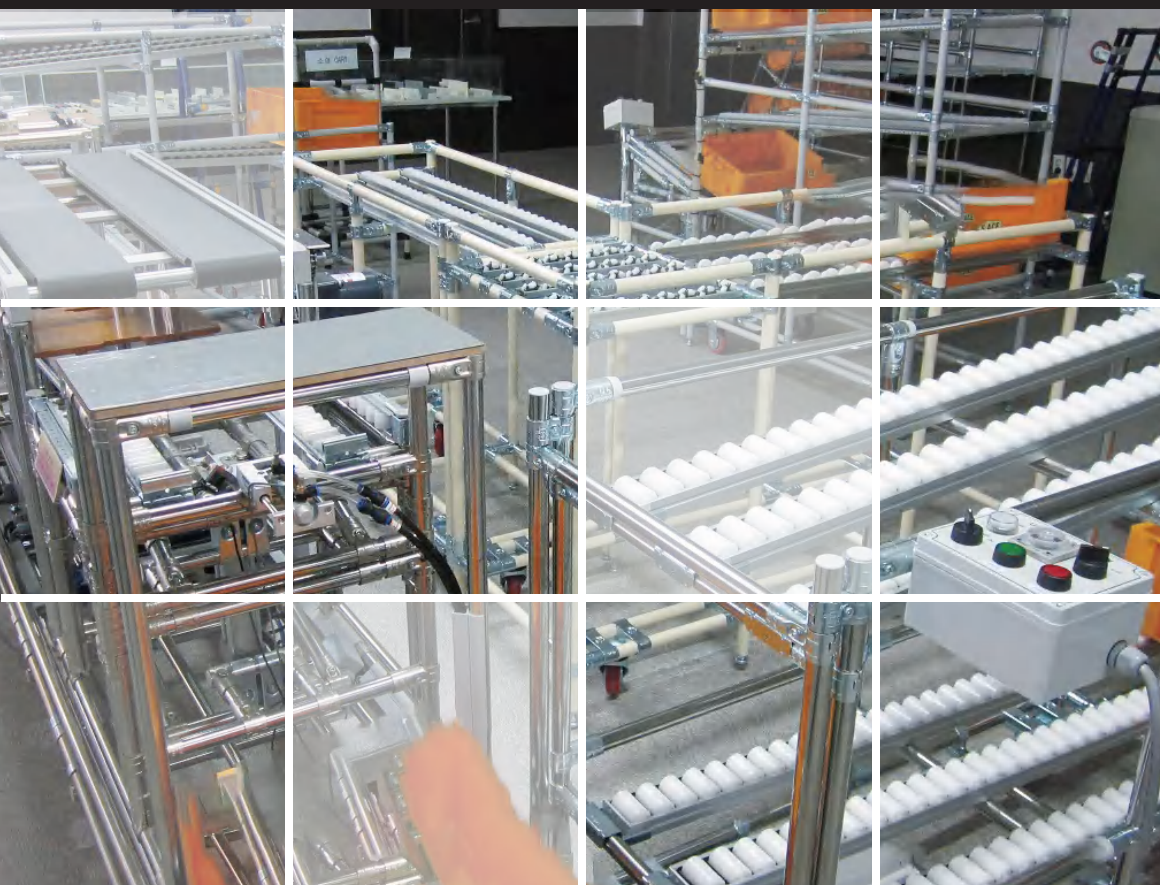

## SERIES 系列

35 series

40 series

60 series

72 series

85 series

### ※ROLLER COLOR 颜色

	ZINC	ZN
	NICKEL	NI
	CHROME	CN

### ※COLOUR 颜色 ● ZINC ○ NICKEL ○ CHROME



Zinc 蓝锌



Nickel 镀镍



Chrome 镀铬

### ※PRODUCT STANDARDS 产品标准

A.welding 焊接

B.Perforated tapping 带孔带牙

## BRAKE PAD 刹车片

**RT-B-40**      COLOR:  ZN



Weight: 45g  
Package: 200pcs

**RT-B-60**      COLOR:  ZN



Weight: 65g  
Package: 200pcs

**RT-B-72**      COLOR:  ZN



Weight: 185g  
Package: 150pcs

**RT-B-85**      COLOR:  ZN



Weight: 115g  
Package: 100pcs

## 35 SERIES 用于 35 系列的铁滑轨

**RTJ-2035C1**      COLOR:  ZN     NI     CN

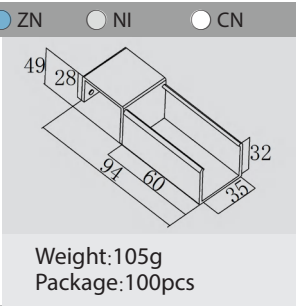
Weight: 105g  
Package: 100pcs

**RTJ-2035C2**      COLOR:  ZN     NI     CN

Weight: 115g  
Package: 100pcs

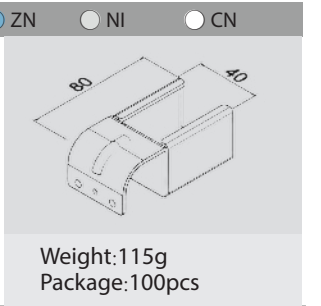
**RTJ-2035CD**      COLOR:  ZN     NI     CN



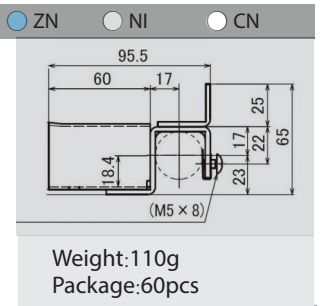

Weight: 110g  
Package: 60pcs

**RTJ-2035D**      COLOR:  ZN     NI     CN

Weight: 110g  
Package: 60pcs

**RTJ-2035D1**      COLOR:  ZN     NI     CN

Weight: 110g  
Package: 60pcs

**RTJ-2035DW**      COLOR:  ZN     NI     CN

Weight: 110g  
Package: 50pcs

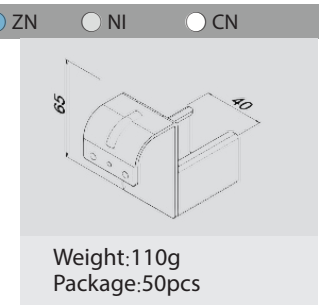

**RTJ-2035E** COLOR:  ZN  NI  CN

Weight:125g  
Package:50pcs

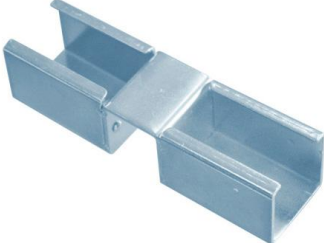
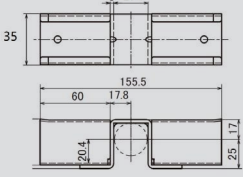
**RTJ-2035U** COLOR:  ZN  NI  CN

Weight:110g  
Package:50pcs

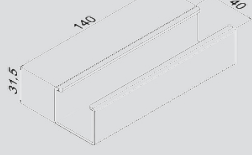
FOR 40 SERIES STEEL PLACON 用于 40 系列的铁滑轨

**RTJ-2040C** COLOR:  ZN  NI  CN

Weight:115g  
Package:100pcs

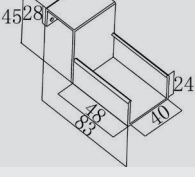
**RTJ-2040D** COLOR:  ZN  NI  CN

Weight:135g  
Package:100pcs

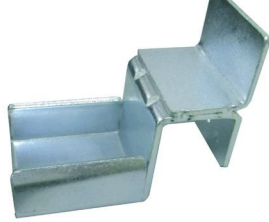
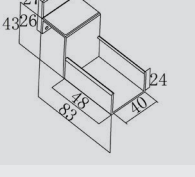
**RTJ-2040DW** COLOR:  ZN  NI  CN

Weight:125g  
Package:50pcs

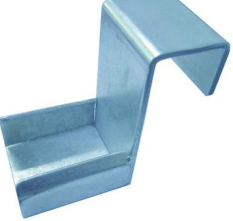
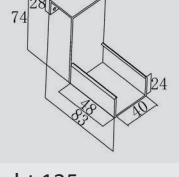
**RTJ-2040E** COLOR:  ZN  NI  CN

Weight:140g  
Package:50pcs

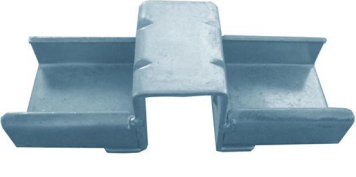
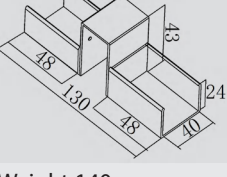
**RTJ-2040P** COLOR:  ZN  NI  CN

Weight:125g  
Package:50pcs

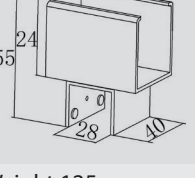
**RTJ-2040U** COLOR:  ZN  NI  CN



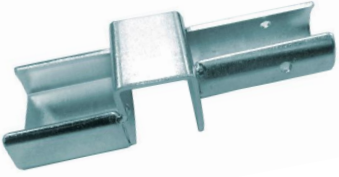
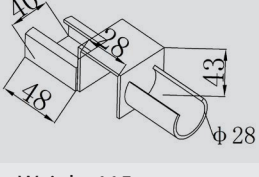

Weight:115g  
Package:50pcs

**RTJ-2040EF** COLOR:  ZN  NI  CN

Weight:115g  
Package:50pcs

**RTJ-2040EP** COLOR:  ZN  NI  CN

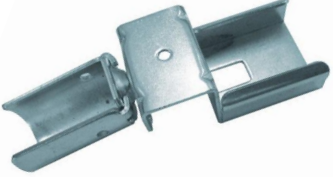
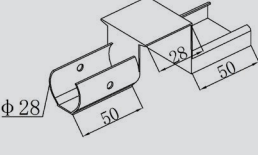
Weight:140g  
Package:25pcs

## FOR 40 SERIES STEEL PLACON

## 用于 40 系列的铁滑轨

RTJ-2040EE

COLOR:  ZN  NI  CN

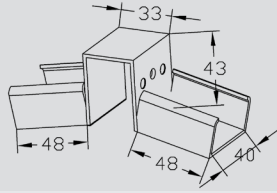
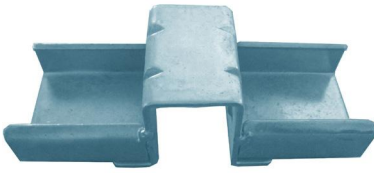

Weight:175g  
Package:50pcs

RTJ-2040CD

COLOR:  ZN  NI  CN

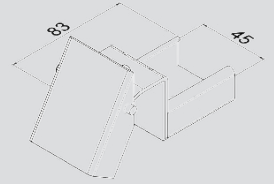

Weight:175g  
Package:50pcs

RTJ-2040CP

COLOR:  ZN  NI  CN

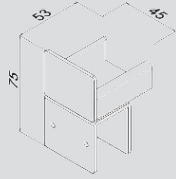

Weight:175g  
Package:50pcs

RTJ-2044C

COLOR:  ZN  NI  CN



Weight:115g  
Package:100pcs

RTJ-2044D

COLOR:  ZN  NI  CN

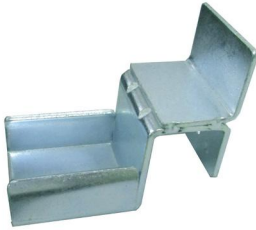

Weight:135g  
Package:100pcs

RTJ-2044DW

COLOR:  ZN  NI  CN



Weight:125g  
Package:50pcs





FOR 40 SERIES ALUMINUM PLACON 用于 40 系列的铝滑轨

RTJ-2040C1

COLOR:  ZN  NI  CN

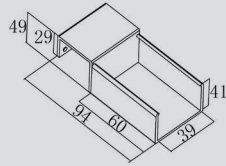
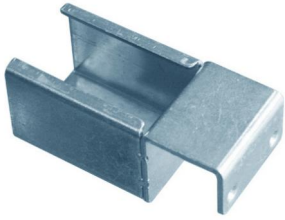

Weight: 120g  
Package: 100pcs

RTJ-2040D1

COLOR:  ZN  NI  CN

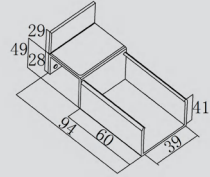
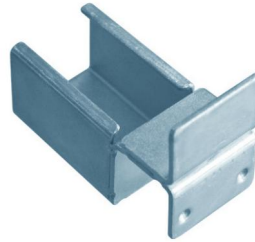

Weight: 135g  
Package: 50pcs

RTJ-2040DW1

COLOR:  ZN  NI  CN

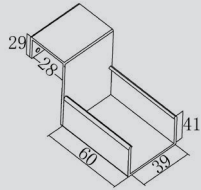
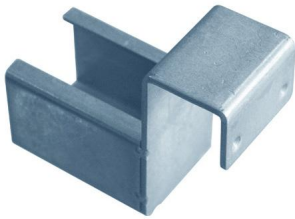

Weight: 125g  
Package: 50pcs

RTJ-2040E1

COLOR:  ZN  NI  CN

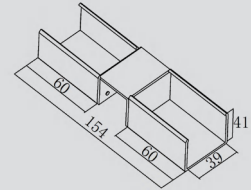
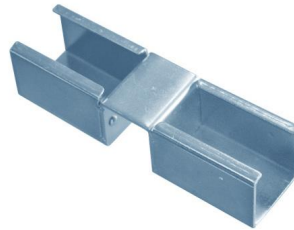

Weight: 248g  
Package: 25pcs

RTJ-2040P1

COLOR:  ZN  NI  CN

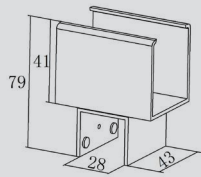
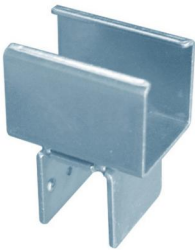

Weight: 125g  
Package: 50pcs

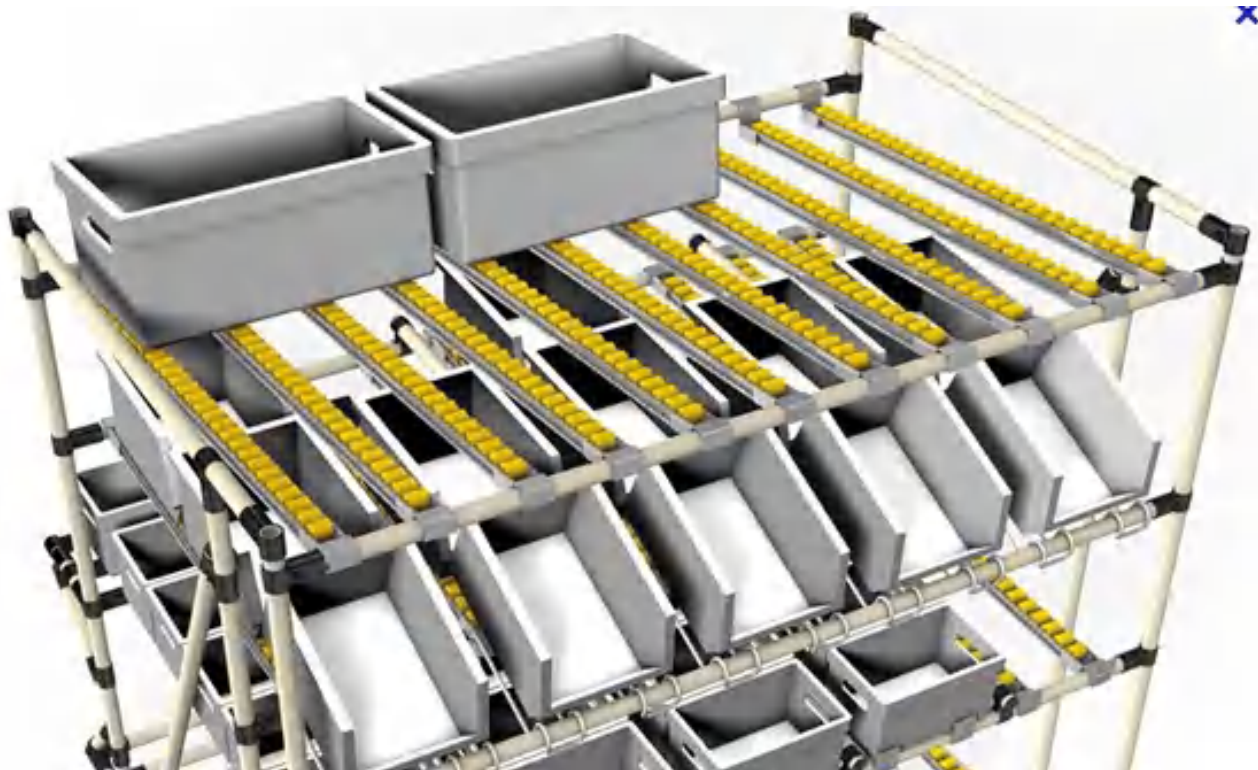



## 60 SERIES 用于 60 系列的铁滑轨

RTJ-2060C-A

COLOR:  ZN  NI  CN

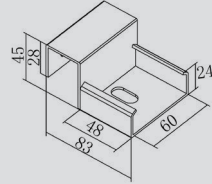
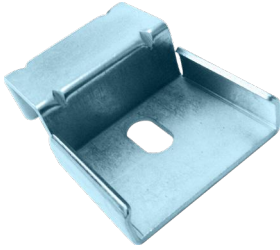

Weight: 175g  
Package: 50pcs

RTJ-2060C-B

COLOR:  ZN  NI  CN

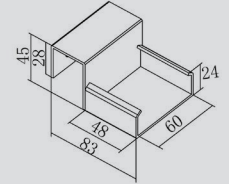

Weight: 170g  
Package: 50pcs

RTJ-2060D-A

COLOR:  ZN  NI  CN

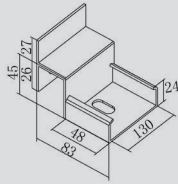
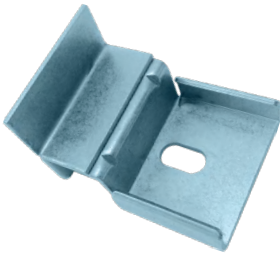

Weight: 190g  
Package: 25pcs

RTJ-2060D-B

COLOR:  ZN  NI  CN

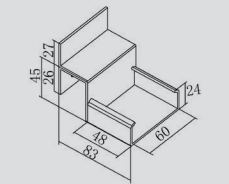
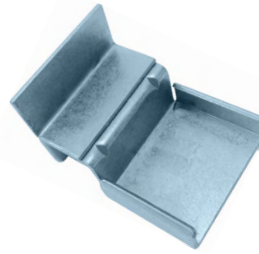

Weight: 190g  
Package: 50pcs

RTJ-2060DW-A

COLOR:  ZN  NI  CN

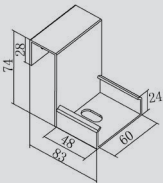
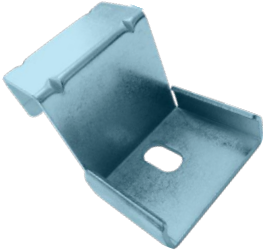

Weight: 180g  
Package: 50pcs

RTJ-2060DW-B

COLOR:  ZN  NI  CN

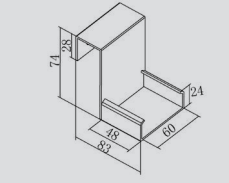

Weight: 180g  
Package: 50pcs

RTJ-2060E-A

COLOR:  ZN  NI  CN

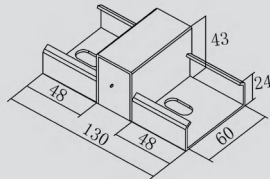
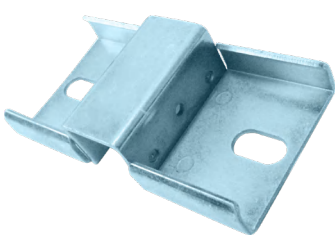

Weight: 290g  
Package: 25pcs

RTJ-2060E-B

COLOR:  ZN  NI  CN

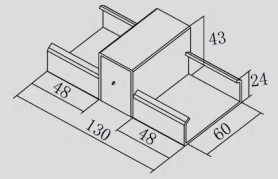

Weight: 290g  
Package: 25pcs

RTJ-2060P-A

COLOR:  ZN  NI  CN

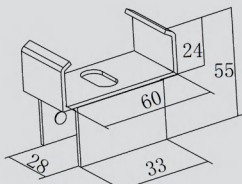
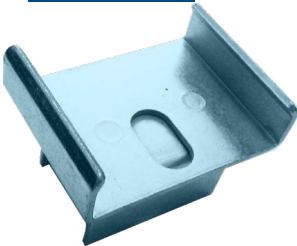

Weight: 160g  
Package: 50pcs

RTJ-2060P-B

COLOR:  ZN  NI  CN

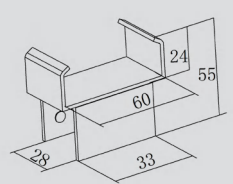
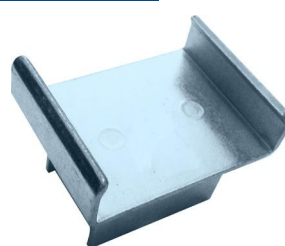

Weight: 160g  
Package: 50pcs

72 SERIES 72 系列

RTJ-2072C

COLOR:  ZN  NI  CN

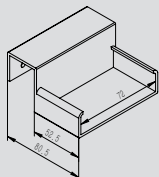
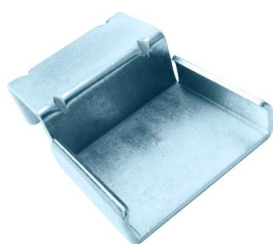

Weight:170g  
Package:50pcs

RTJ-2072D

COLOR:  ZN  NI  CN

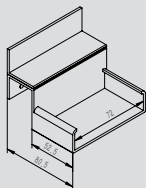

Weight:200g  
Package:25pcs

RTJ-2072DW

COLOR:  ZN  NI  CN

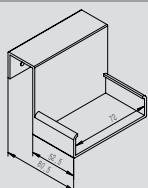

Weight:190g  
Package:50pcs

RTJ-2072E

COLOR:  ZN  NI  CN

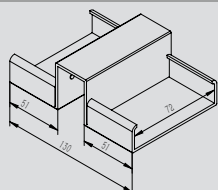

Weight:290g  
Package:25pcs

RTJ-2072P

COLOR:  ZN  NI  CN

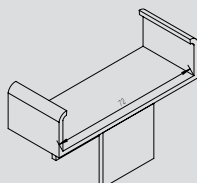

Weight:160g  
Package:50pcs

85 SERIES 85 系列

RTJ-2085C

COLOR:  ZN  NI  CN

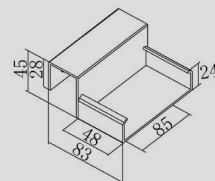

Weight:180g  
Package:50pcs

RTJ-2085D

COLOR:  ZN  NI  CN

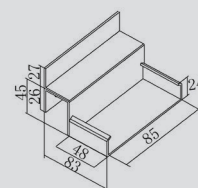
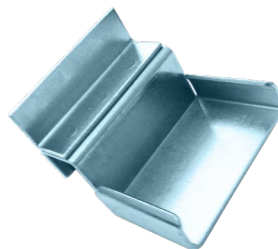

Weight:200g  
Package:25pcs

RTJ-2085DW

COLOR:  ZN  NI  CN

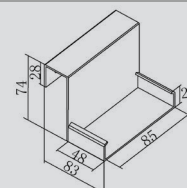
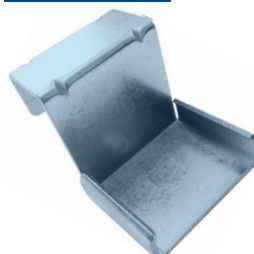

Weight:190g  
Package:50pcs

RTJ-2085E

COLOR:  ZN  NI  CN

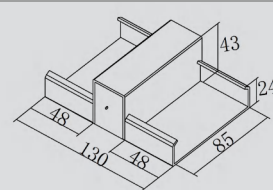
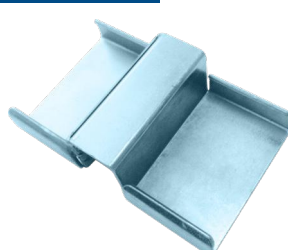

Weight:300g  
Package:25pcs

RTJ-2085P

COLOR:  ZN  NI  CN

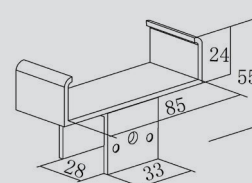

Weight:160g  
Package:50pcs

## SLIDE PIPE BRACKET 滑动管接头

SLPJ-CF

COLOR:  ZN  NI  CN

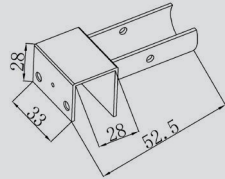
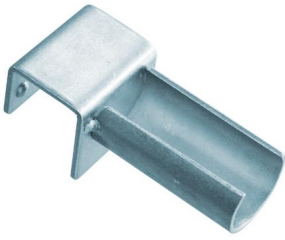

Weight:150g  
Package:50pcs

SLPJ-DF

COLOR:  ZN  NI  CN

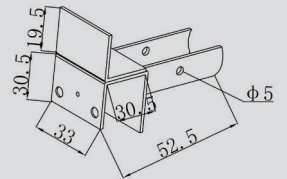

Weight:250g  
Package:50pcs

SLPJ-WF

COLOR:  ZN  NI  CN

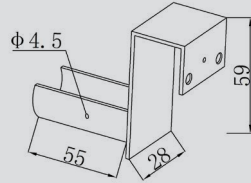

Weight:180g  
Package:50pcs

SLPJ-EF

COLOR:  ZN  NI  CN

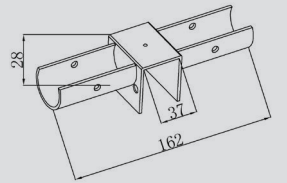
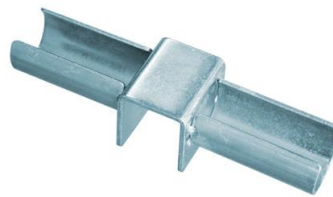

Weight:220g  
Package:25pcs

SLPJ-FF

COLOR:  ZN  NI  CN

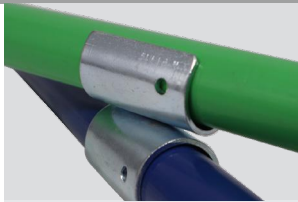

Weight:140g  
Package:50pcs

SLPJ-PF

COLOR:  ZN  NI  CN

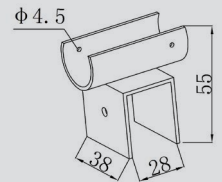

Weight:150g  
Package:50pcs





SLIDE PIPE BRACKET FOR 28.6 滑动管接头 - 配 28.6 管

S-CF

COLOR:  ZN  NI  CN

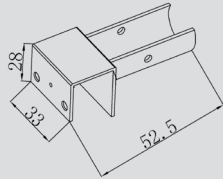

Weight:150g  
Package:50pcs

S-DF

COLOR:  ZN  NI  CN

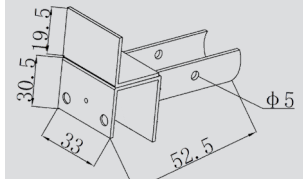

Weight:250g  
Package:50pcs

S-WF

COLOR:  ZN  NI  CN

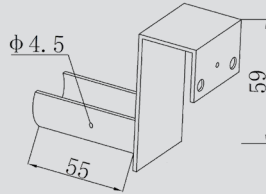

Weight:180g  
Package:50pcs

S-EF

COLOR:  ZN  NI  CN

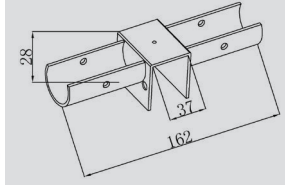

Weight:220g  
Package:25pcs

S-FF

COLOR:  ZN  NI  CN

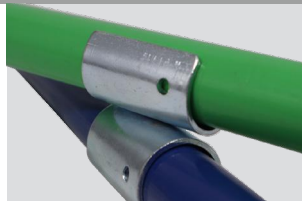

Weight:140g  
Package:50pcs

S-PF

COLOR:  ZN  NI  CN

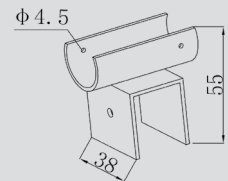
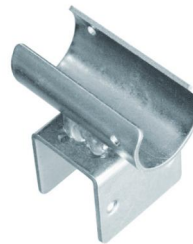

Weight:150g  
Package:50pcs



# ACCESSORIES 配件



## CASTER 脚轮

## 01 FIXED SERIES 平板固定脚轮系列

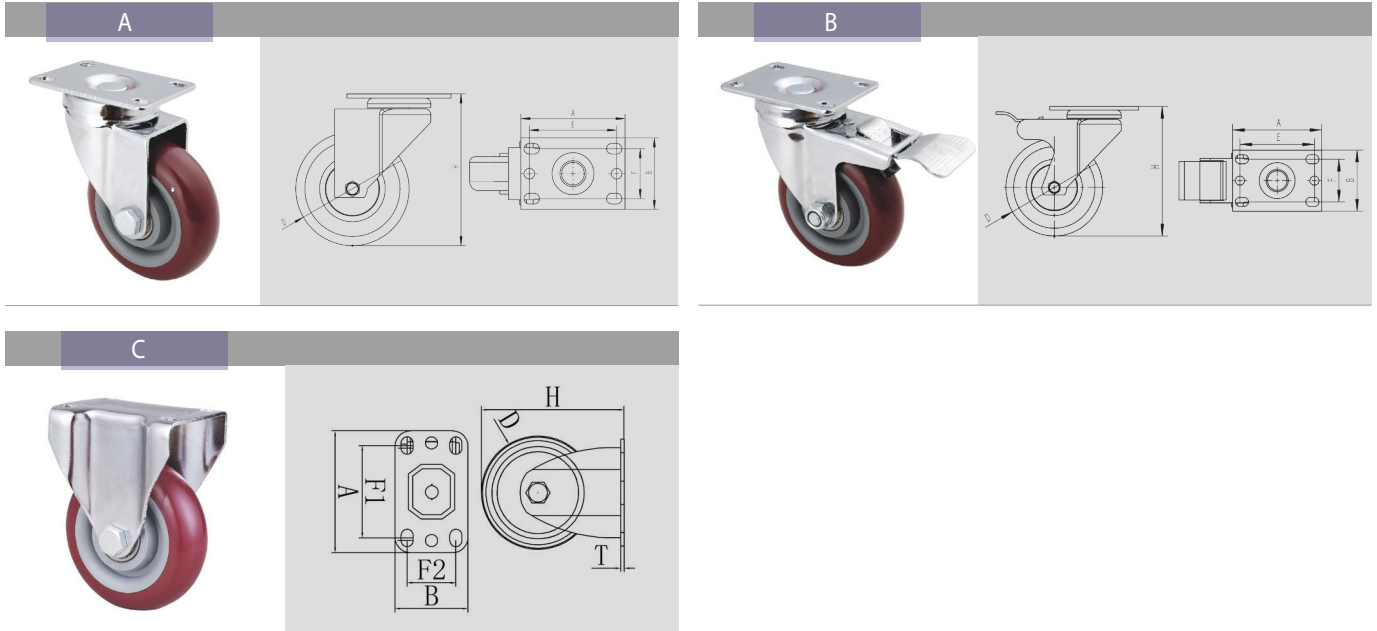

Flat plate fixed Series 固定脚轮	Wheel Dia 轮径 (inch)	D 轮径 (mm)	A*B 底板尺寸	Material 轮子材质	Frame Material 支架材质	Offset DistancePIA 偏心距 (mm)	Loading 承重 (N)	H 高度 (mm)	Weight 单重 (g)	Package 每箱 (pcs)
WJ-301A	3"	75mm	70*60	TPR/PU/Rubber	steel	35	800	95	630	50
WJ-301A-ESD	3"	75mm	70*60	TPR/Rubber	steel	35	800	95	630	50
WJ-301B	3"	75mm	70*60	TPR/PU/Rubber	steel	35	800	95	730	50
WJ-301B-ESD	3"	75mm	70*60	TPR/Rubber	steel	35	800	95	730	50
WJ-301C	3"	75mm	70*60	TPR/PU/Rubber	steel	/	800	95	450	50
WJ-301C-ESD	3"	75mm	70*60	TPR/Rubber	steel	/	800	95	450	50
WJ-401A	4"	100mm	90*100	TPR/PU/Rubber	steel	32	1200	132	740	40
WJ-401A-ESD	4"	100mm	90*100	TPR/Rubber	steel	32	1200	132	740	40
WJ-401B	4"	100mm	90*100	TPR/PU/Rubber	steel	32	1200	132	910	40
WJ-401B-ESD	4"	100mm	90*100	TPR/Rubber	steel	32	1200	132	910	40
WJ-401C	4"	100mm	90*100	TPR/PU/Rubber	steel	/	1200	132	550	40
WJ-401C-ESD	4"	100mm	90*100	TPR/Rubber	steel	/	1200	132	550	40
WJ-501A	5"	125mm	120*110	TPR/PU/Rubber	steel	32	1600	190	900	30
WJ-501A-ESD	5"	125mm	120*110	TPR/Rubber	steel	32	1600	190	900	30
WJ-501B	5"	125mm	120*110	TPR/PU/Rubber	steel	32	1600	190	1050	30
WJ-501B-ESD	5"	125mm	120*110	TPR/PU/Rubber	steel	32	1600	190	1050	30
WJ-501C	5"	125mm	120*110	TPR/Rubber	steel	/	1600	190	750	30
WJ-501C-ESD	5"	125mm	120*110	TPR/PU/Rubber	steel	/	1600	190	750	30



## CASTER 脚轮

### 02 INSERTION SERIES 插杆脚轮系列

ACCESSORIES 配件

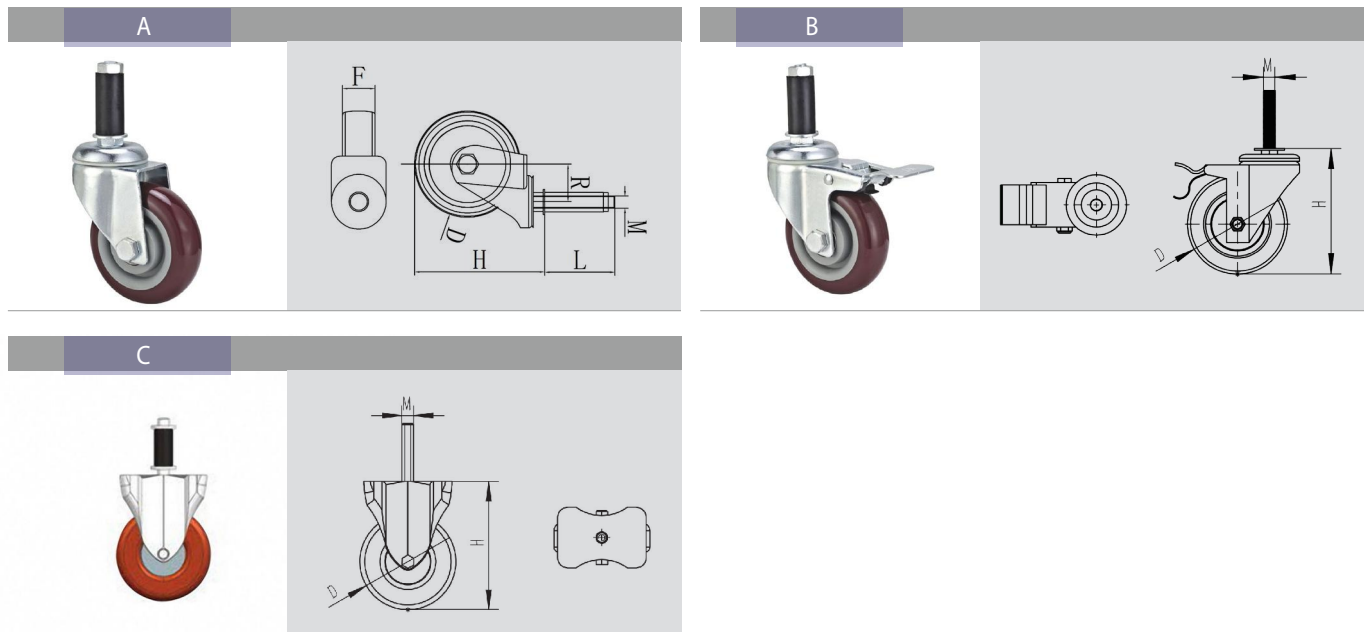

Insertion Caster Series 插杆脚轮	Wheel Dia 轮径 (inch)	D 轮径 (mm)	T 丝杆外径	Material 轮子材质	Frame Material 支架材质	Offset Distance PIA 偏心距 (mm)	Loading 承重 (N)	H 高度 (mm)	Weight 单重 (g)	Package 每箱 (pcs)
WJ-202A	2"	50mm	M12*60	TPR/PU/Rubber	steel	22	300	67	280	100
WJ-202A-ESD	2"	50mm	M12*60	TPR/Rubber	steel	22	300	67	280	100
WJ-202B	2"	50mm	M12*60	TPR/PU/Rubber	steel	22	300	67	300	100
WJ-202B-ESD	2"	50mm	M12*60	TPR/Rubber	steel	22	300	67	300	100
WJ-202C	2"	50mm	M12*60	TPR/PU/Rubber	steel	/	300	67	280	100
WJ-202C-ESD	2"	50mm	M12*60	TPR/Rubber	steel	/	300	67	280	100
WJ-302A	3"	75mm	M12*60	TPR/PU/Rubber	steel	35	500	95	480	50
WJ-302A-ESD	3"	75mm	M12*60	TPR/Rubber	steel	35	500	95	480	50
WJ-302B	3"	75mm	M12*60	TPR/PU/Rubber	steel	35	500	95	580	50
WJ-302B-ESD	3"	75mm	M12*60	TPR/Rubber	steel	35	500	95	580	50
WJ-302C	3"	75mm	M12*60	TPR/PU/Rubber	steel	/	500	95	450	50
WJ-302C-ESD	3"	75mm	M12*60	TPR/Rubber	steel	/	500	95	450	50
WJ-402A	4"	100mm	M12*60	TPR/PU/Rubber	steel	32	600	132	630	40
WJ-402A-ESD	4"	100mm	M12*60	TPR/Rubber	steel	32	600	132	630	40
WJ-402B	4"	100mm	M12*60	TPR/PU/Rubber	steel	32	600	132	780	40
WJ-402B-ESD	4"	100mm	M12*60	TPR/Rubber	steel	32	600	132	780	40
WJ-402C	4"	100mm	M12*60	TPR/PU/Rubber	steel	/	600	132	620	40
WJ-402C-ESD	4"	100mm	M12*60	TPR/Rubber	steel	/	600	132	620	40

## CASTER 脚轮

## 03 BUSHING SERIES 螺杆插入式脚轮系列

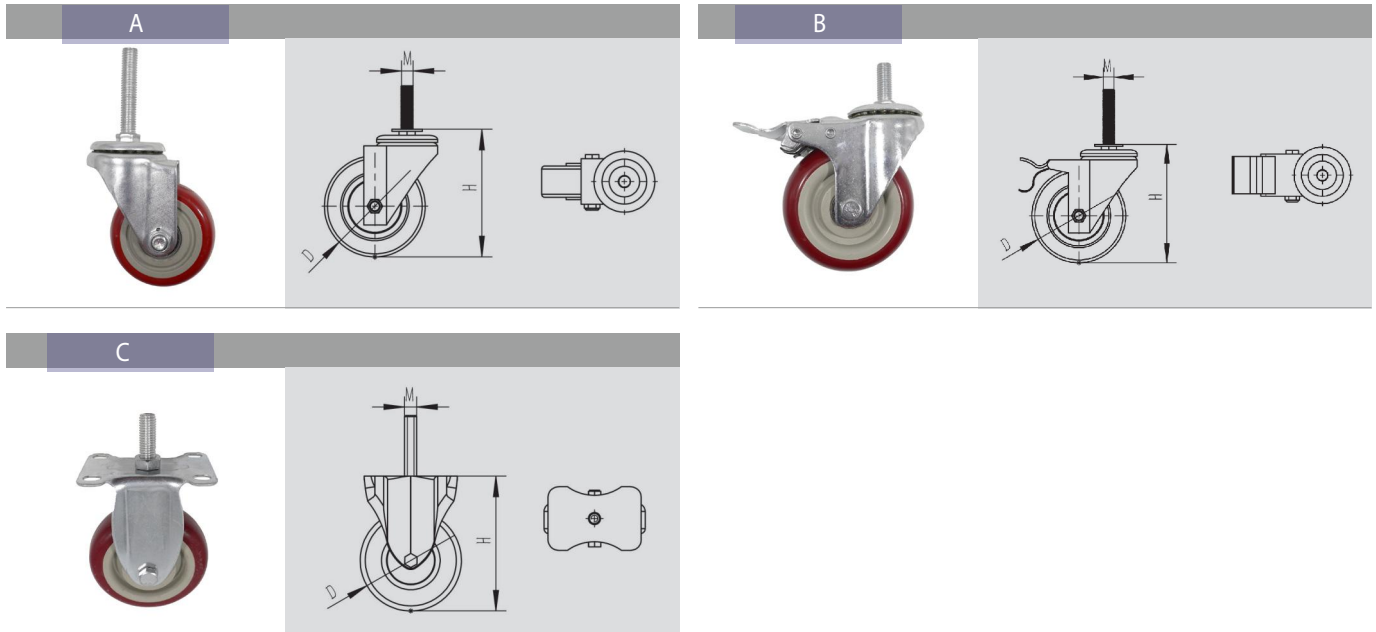

Bushing Caster 螺杆插入式	Wheel Dia 轮径 (inch)	D 轮径 (mm)	T 丝杆外径	Material 轮子材质	Frame Material 支架材质	Offset DistancePIA 偏心距 (mm)	Loading 承重 (N)	H 高度 (mm)	Weight 单重 (g)	Package 每箱 (pcs)
WJ-203A	2"	50mm	M12*35	TPR/PU/Rubber	steel	22	300	67	280	100
WJ-203A-ESD	2"	50mm	M12*35	TPR/Rubber	steel	22	300	67	280	100
WJ-203B	2"	50mm	M12*35	TPR/PU/Rubber	steel	22	300	67	300	100
WJ-203B-ESD	2"	50mm	M12*35	TPR/Rubber	steel	22	300	67	300	100
WJ-203C	2"	50mm	M12*35	TPR/PU/Rubber	steel	/	300	67	280	100
WJ-203C-ESD	2"	50mm	M12*35	TPR/Rubber	steel	/	300	67	280	100
WJ-303A	3"	75mm	M12*35	TPR/PU/Rubber	steel	35	500	95	480	50
WJ-303A-ESD	3"	75mm	M12*35	TPR/Rubber	steel	35	500	95	480	50
WJ-303B	3"	75mm	M12*35	TPR/PU/Rubber	steel	35	500	95	580	50
WJ-303B-ESD	3"	75mm	M12*35	TPR/Rubber	steel	35	500	95	580	50
WJ-303C	3"	75mm	M12*35	TPR/PU/Rubber	steel	/	500	95	450	50
WJ-303C-ESD	3"	75mm	M12*35	TPR/Rubber	steel	/	500	95	450	50
WJ-403A	4"	100mm	M12*35	TPR/PU/Rubber	steel	32	600	132	630	40
WJ-403A-ESD	4"	100mm	M12*35	TPR/Rubber	steel	32	600	132	630	40
WJ-403B	4"	100mm	M12*35	TPR/PU/Rubber	steel	32	600	132	780	40
WJ-403B-ESD	4"	100mm	M12*35	TPR/Rubber	steel	32	600	132	780	40
WJ-403C	4"	100mm	M12*35	TPR/PU/Rubber	steel	/	600	132	620	40
WJ-403C-ESD	4"	100mm	M12*35	TPR/Rubber	steel	/	600	132	620	40

## Adjust Accessory Type | 脚杯附件类

### 28AD-8A

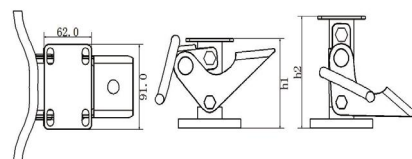

Item No 型号	specification 规格	Frame Material 支架材质	A*B 底板尺寸	H1高度 (mm)	H2 伸展后高度 (mm)	Loading 承重 (N)	weight 重量 (KG)
28AD-8A-3	3"	steel	62*91	96	120	80kg	1.4kg
28AD-8A-4	4"	steel	62*91	125	151	100kg	1.6kg
28AD-8A-5	5"	steel	62*91	154	180	120kg	1.8kg



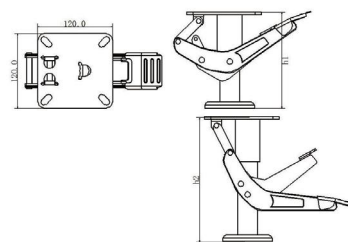







### 28AD-8B

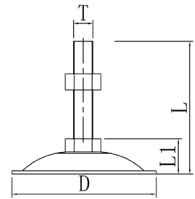

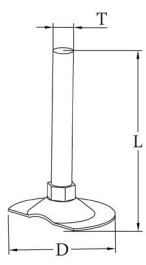

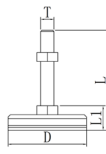
Item No 型号	specification 规格	Frame Material 支架材质	A*B 底板尺寸	H1高度 (mm)	H2 伸展后高度 (mm)	Loading 承重 (N)	weight 重量 (KG)
28AD-8B-5	5"	steel	120*120	154	180	150KG	1.8kg
28AD-8B-6	6"	steel	120*120	170	200	200KG	2.2kg

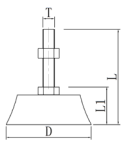

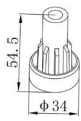



## ADJUST 脚杯

Series 系列	Code 型号	D/ 直径 (mm)	Hight 高度 /L (mm)	Stem Diameter 丝杆外径 (t)	Picture 图片	Drawing 图纸
Small-Type 小型	SPB28E-10(SP30E-10)	28(30)	/	M10		SPB28E = 28MMTUBE SP30E = 28.6MMTUBE
	SPB28E-12(SP30E-12)	28(30)	/	M12		
	SPB28E- 1/2(SP30E-1/2)	28(30)	/	1/2"		
	SPB28E- 3/8(SP30E-3/8)	28(30)	/	3/8"		
	ADP3-34	34	/	/		
	ADP3-52	52	/	/		
Normal-Type 标准型	AD3-3850-10	38	50	M10		
	AD3-3850- 3/8	38	50	3/8"		
	AD3-3880-10	38	80	M10		
	AD3-3880- 3/8	38	80	3/8"		
	AD3-5050-10	50	50	M10		
	AD3-5050- 3/8	50	50	3/8"		
	AD3-50100-12	50	100	M12		
	AD3-50100- 1/2	50	100	1/2"		
	AD3-50100- 5/8	50	100	5/8"		
	AD4-3850-10	38	50	M10		
	AD4-3850- 3/8	38	50	3/8"		
	AD4-3880-10	38	80	M10		
	AD4-3880- 3/8	38	80	3/8"		
	AD4-5050-10	50	50	M10		
	AD4-5050- 3/8	50	50	3/8"		
	AD4-50100-12	50	100	M12		
	AD4-50100- 1/2	50	100	1/2"		
	AD4-50100- 5/8	50	100	5/8"		
Rubber-Type ESD BLACK 橡胶型 ESD 黑色	AD5-3850-10	38	50	M10		
	AD5-3880-10	38	80	M10		
	AD5-38100-10	38	100	M10		
	AD5-5080-10	50	80	M10		
	AD5-3880-12	38	100	M12		
Rubber Pad-Type ESD BLACK 橡胶垫型 ESD 黑色	AD6-3260-10	32	60	M10		
	AD6-3560-10	35	60	M10		
	AD6-5460-10	54	60	M10		
	AD6-5460-12	54	60	M12		
Adjust accessories 脚杯附件	WA-AD5-10	/	/	M10		
	WA-AD5-12	/	/	M12		
	WA-AD5- 1/2	/	/	1/2"		
	WA-AD5- 3/8	/	/	3/8"		

## BUSHING NUT 铜套螺母

Part Number	Photo	Classification	Application	Diameter 孔径	QTY(pcs) 数量	Color 颜色
SPB2807-10 (SPB3007-10)		Stainless pipe	28*0.7 (28.6*0.7)	M10	200	ZINC
SPB2807-12 (SPB3007-12)			28*0.7(28.6*0.7)	M12	200	ZINC
SPB2807- 1/2 (SPB3007- 1/2)			28*0.7 (28.6*0.7)	1/2"	200	ZINC
SPB2807- 3/8 (SPB3007- 3/8)			28*0.7(28.6*0.7)	3/8"	200	ZINC
SPB2807- 5/8 (SPB3007- 5/8)			28*0.7 (28.6*0.7)	5/8"	200	ZINC
SPB2810- 10 (SPB3010-10)		Stainless pipe	28*1.0 (28.6*1.0)	M10	200	ZINC
SPB2810-12 (SPB3010-12)			28*1.0 (28.6*1.0)	M12	200	ZINC
SPB2810-1/2 (SPB3010- 1/2)			28*1.0 (28.6*1.0)	1/2"	200	ZINC
SPB2810- 3/8 (SPB3010- 3/8)			28*1.0 (28.6*1.0)	3/8"	200	ZINC
SPB2810- 5/8 (SPB3010- 5/8)			28*1.0 (28.6*1.0)	5/8"	200	ZINC
SPB2812- 10 (SPB3012-10)		Stainless pipe	28*1.2 (28.6*1.2)	M10	200	ZINC
SPB2812-12 (SPB3012-12)			28*1.2 (28.6*1.2)	M12	200	ZINC
SPB2812-1/2 (SPB3012- 1/2)			28*1.2 (28.6*1.2)	1/2"	200	ZINC
SPB2812- 3/8 (SPB3012- 3/8)			28*1.2 (28.6*1.2)	3/8"	200	ZINC
SPB2812- 5/8 (SPB3012- 5/8)			28*1.2 (28.6*1.2)	5/8"	200	ZINC

## BUSHING NUT 铜套螺母

Part Number	Photo	Classification	Application	Diameter 孔径	QTY(pcs) 数量	Color 颜色
CPB2807-10 (CPB3007-10)		Coated pipe	28*0.7 (28.6*0.7)	M10	200	ZINC
CPB2807-12 (CPB3007-12)			28*0.7 (28.6*0.7)	M12	200	ZINC
CPB2807- 1/2 (CPB3007-1/2)			28*0.7 (28.6*0.7)	1/2"	200	ZINC
CPB2807- 3/8 (CPB3007-3/8)			28*0.7 (28.6*0.7)	3/8"	200	ZINC
CPB2807- 5/8 (CPB3007-5/8)			28*0.7 (28.6*0.7)	5/8"	200	ZINC
CPB2810-10 (CPB3010-10)		Coated pipe	28*1.0 (28.6*1.0)	M10	200	ZINC
CPB2810-12 (CPB3010-12)			28*1.0 (28.6*1.0)	M12	200	ZINC
CPB2810-1/2 (CPB3012-1/2)			28*1.0 (28.6*1.0)	1/2"	200	ZINC
CPB2810- 3/8 (CPB3010-3/8)			28*1.0 (28.6*1.0)	3/8"	200	ZINC
CPB2810- 5/8 (CPB3010-5/8)			28*1.0 (28.6*1.0)	5/8"	200	ZINC
CPB2812- 10 (CPB3012-10)		Coated pipe	28*1.2 (28.6*1.2)	M10	200	ZINC
CPB2812-12 (CPB3012-12)			28*1.2 (28.6*1.2)	M12	200	ZINC
CPB2812-1/2 (CPB3012-1/2)			28*1.2 (28.6*1.2)	1/2"	200	ZINC
CPB2812- 3/8 (CPB3012-3/8)			28*1.2 (28.6*1.2)	3/8"	200	ZINC
CPB2812- 5/8 (CPB3012-5/8)			28*1.2 (28.6*1.2)	5/8"	200	ZINC
CPB2815- 10 (CPB3015-10)		Coated pipe	28*1.5 (28.6*1.5)	M10	200	ZINC
CPB2815-12 (CPB3015-12)			28*1.5 (28.6*1.5)	M12	200	ZINC
CPB2815-1/2 (CPB3015-1/2)			28*1.5 (28.6*1.5)	1/2"	200	ZINC
CPB2815- 3/8 (CPB3015-3/8)			28*1.5 (28.6*1.5)	3/8"	200	ZINC
CPB2815- 5/8 (CPB3015-5/8)			28*1.5 (28.6*1.5)	5/8"	200	ZINC
CPB2820- 10 (CPB3020-10)		Coated pipe	28*2.0 (28.6*2.0)	M10	200	ZINC
CPB2820-12 (CPB3020-12)			28*2.0 (28.6*2.0)	M12	200	ZINC
CPB2820-1/2 (CPB3020-1/2)			28*2.0 (28.6*2.0)	1/2"	200	ZINC
CPB2820- 3/8 (CPB3020-3/8)			28*2.0 (28.6*2.0)	3/8"	200	ZINC
CPB2820- 5/8 (CPB3020-5/8)			28*2.0 (28.6*2.0)	5/8"	200	ZINC



PLASTIC STRIP 塑胶条

JP-A-30

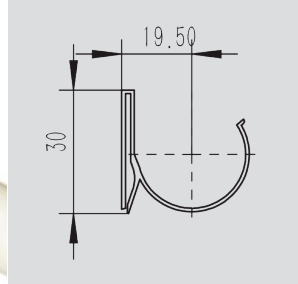

JP-A-50

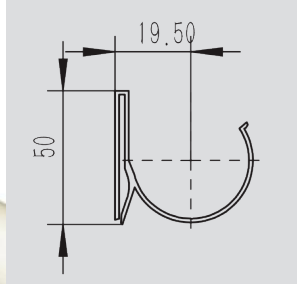

JP-B1

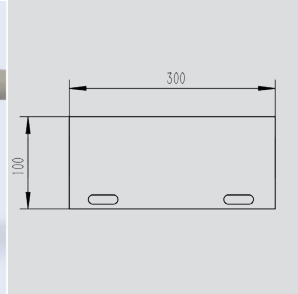

JP-B2

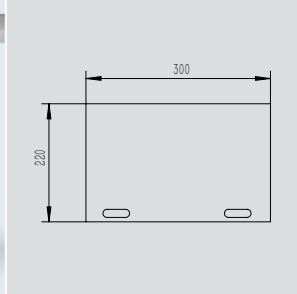

JP-B3

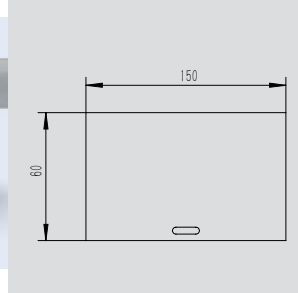
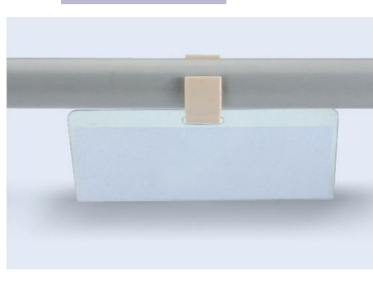

JP-B4

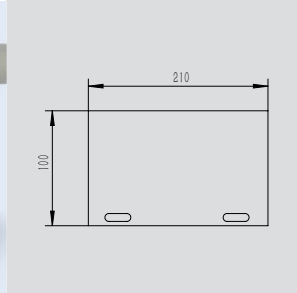

JP-B5

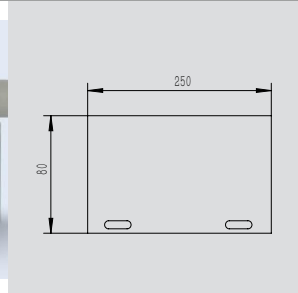
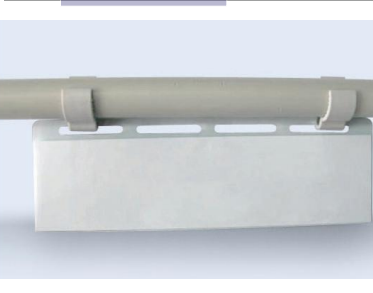

JP-C1

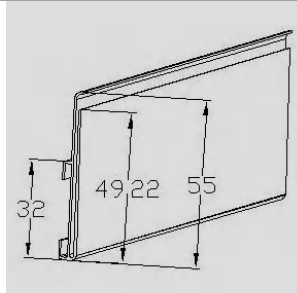
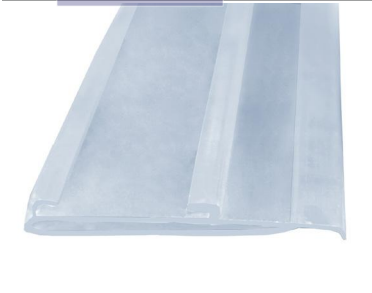

JP-C2

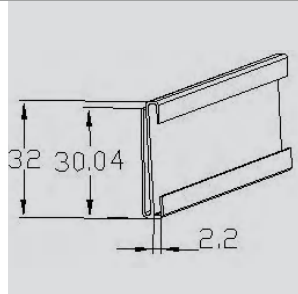

JP-D1-35

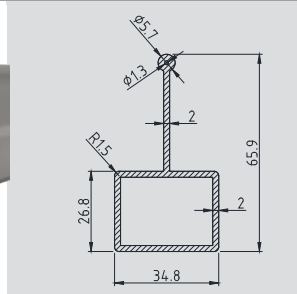

for 35 series roller track

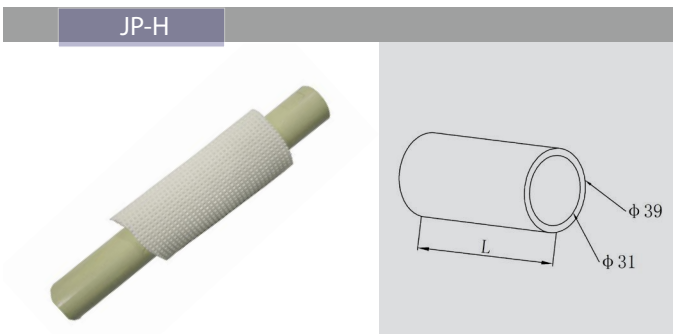
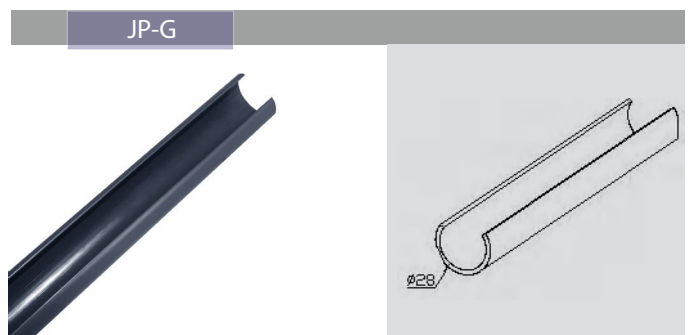
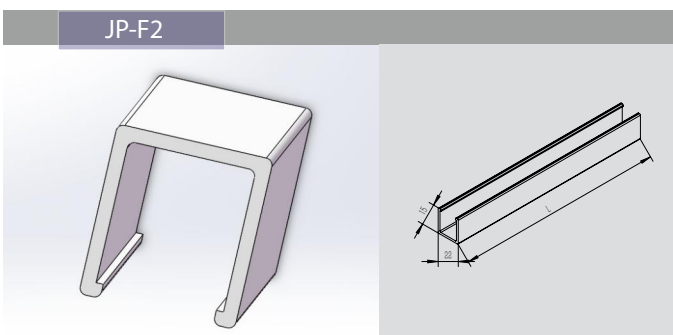
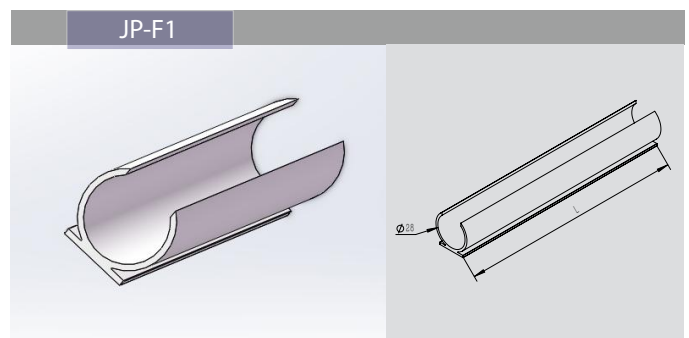
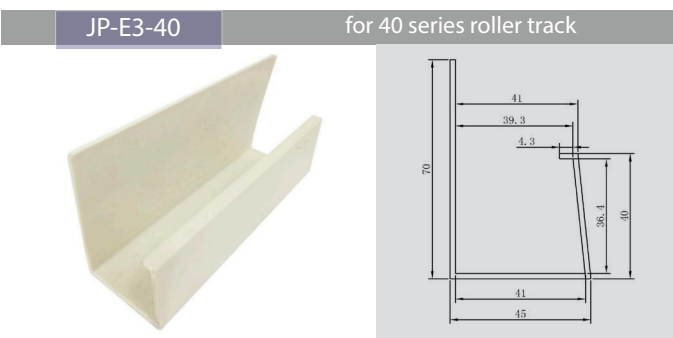
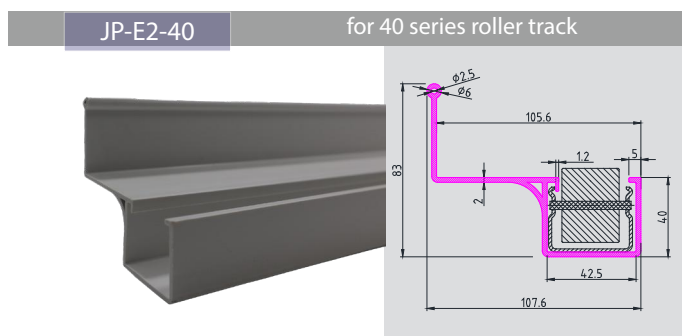
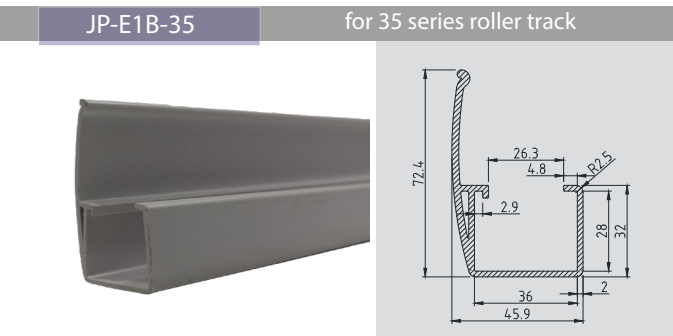
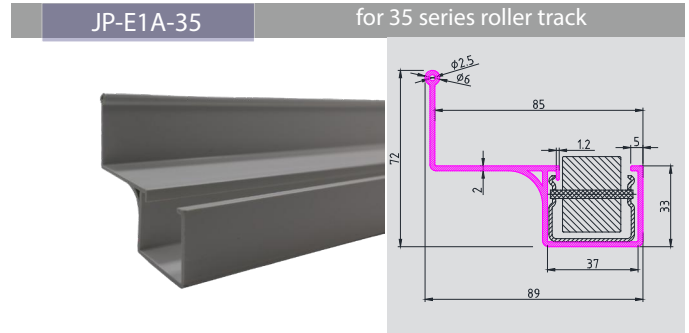
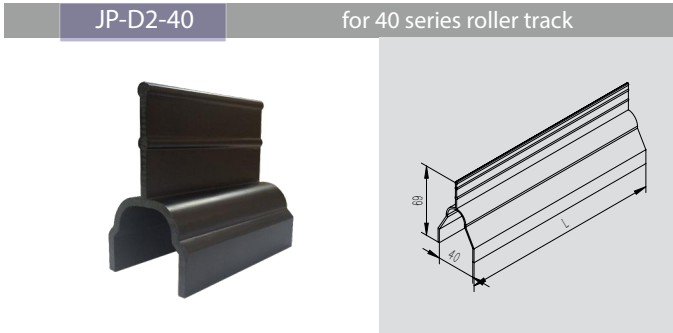

PLASTIC STRIP 塑胶条

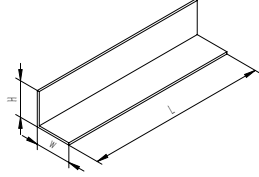

PLASTIC STRIP 塑胶条

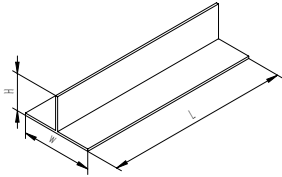
Series 系列	Code 型号	Hight 高度 / L (mm)	Width/ 宽度 W (mm)	Picture 图片	Drawing 图纸
L-type L 型	JP-L1	35	35		
	JP-L2	35	40		
	JP-L3	30	50		
	JP-L4	50	60		
	JP-L5	50	75		
	JP-L6	50	100		
	JP-L7	80	90		
T-type T 型	JP-T1	50	100		
	JP-T2	100	60		





METAL ACCESSORIES 五金配件

WA-1000A

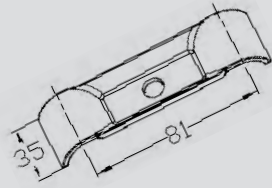
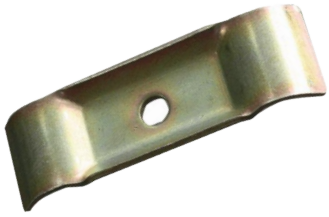

WA-1000A1

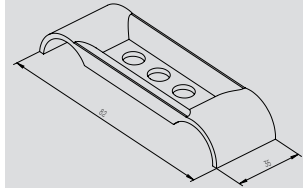

WA-1000B

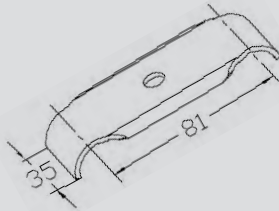

WA-1000B1

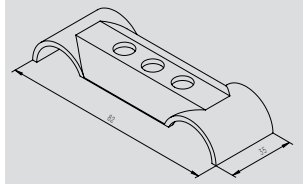

WA-1000C

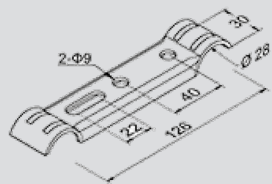

WA-1000C1

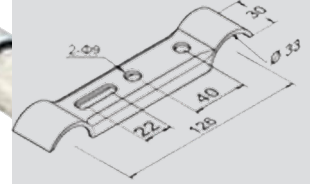

WA-1000D

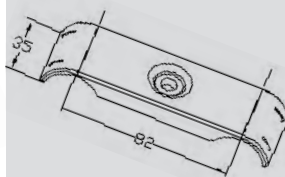

WA-1000D1

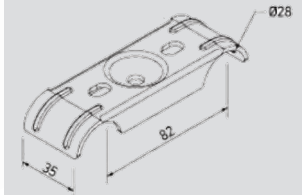

WA-1008A

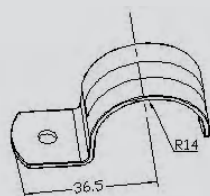

WA-1008B

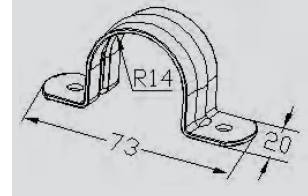

METAL ACCESSORIES 五金配件

WA-1008C

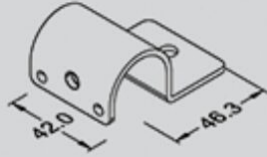
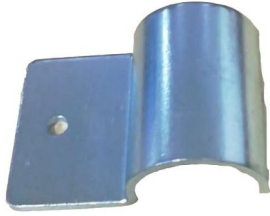

WA-1008D

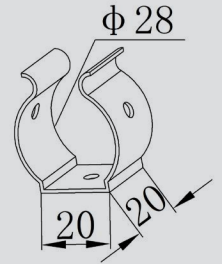

WA-1

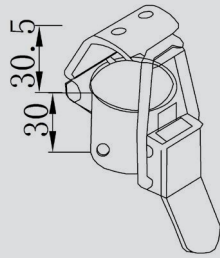

WA-2

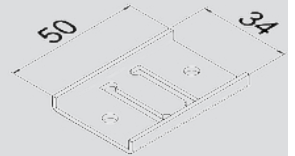

WA-3A

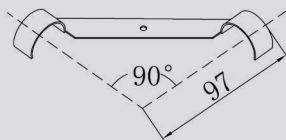

WA-4

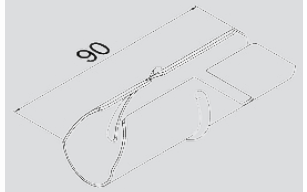

For Thickness 0.7/1.0/1.2mm

WA-5A

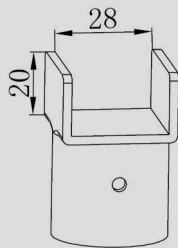

WA-5B

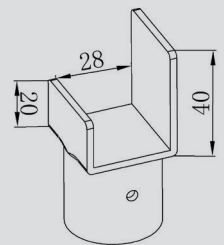

WA-5C

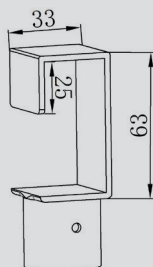

WA-6

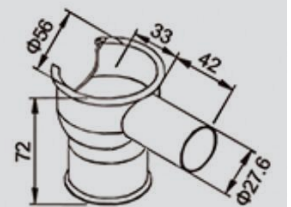

METAL ACCESSORIES 五金配件

WA-7

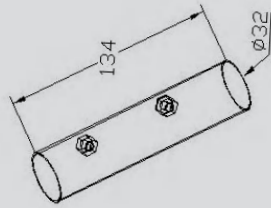

WA-8

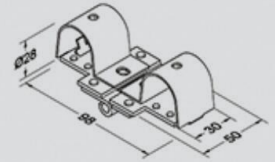

WA-9

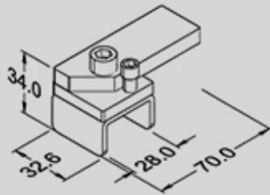

WA-L

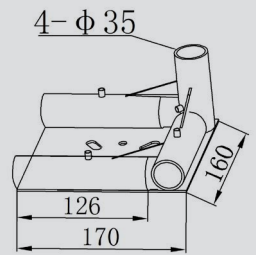

WA-LR

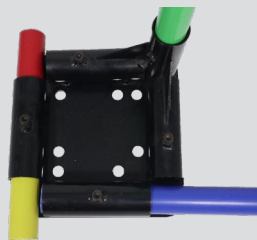

WA-T

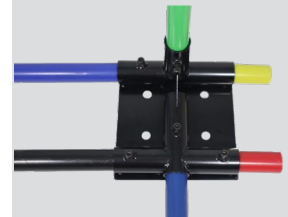

WA-R

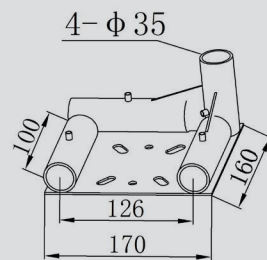

WA-P1

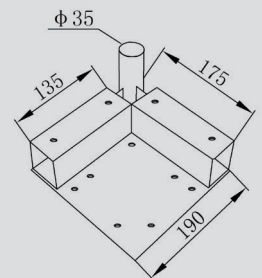

WA-P2

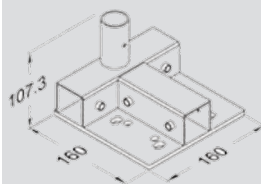

WA-P3

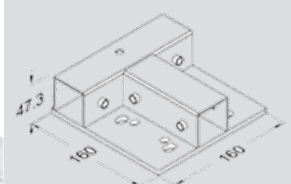

METAL ACCESSORIES 五金配件

WA-Y

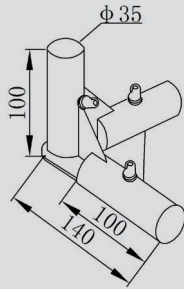

WA-F

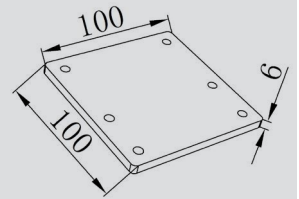

WA-1005A



WA-1005B



WA-1005C

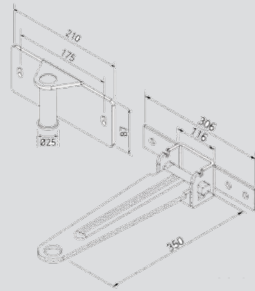

WA-1005D

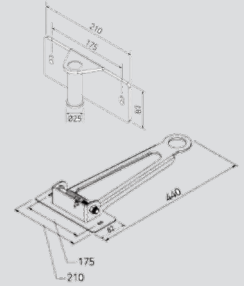
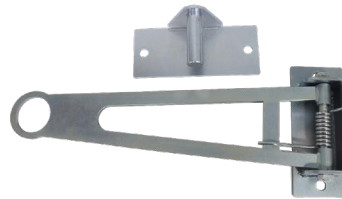

WA-1006

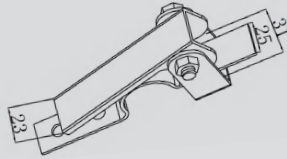

WA-1009

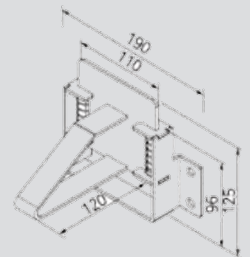

WA-1012A

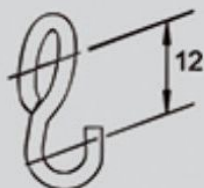

WA-1012B





METAL ACCESSORIES 五金配件

WA-1012C



WA-1012D

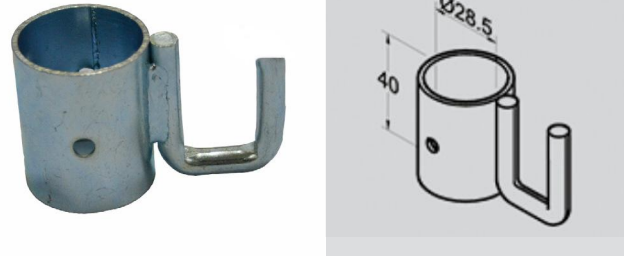

WA-1012E

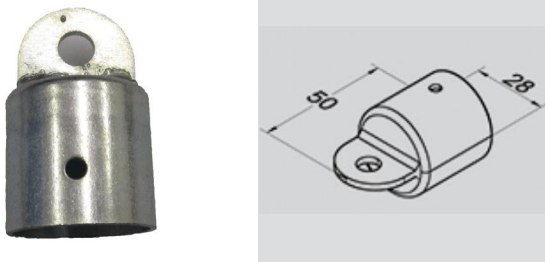

WA-1012F

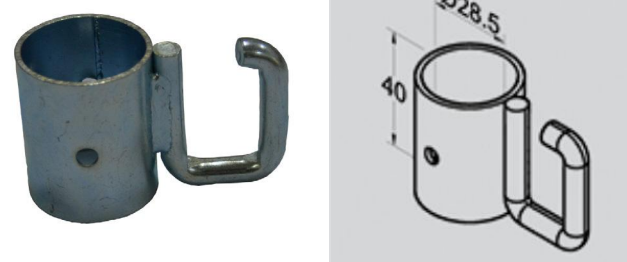

WA-1012G



WA-1012H

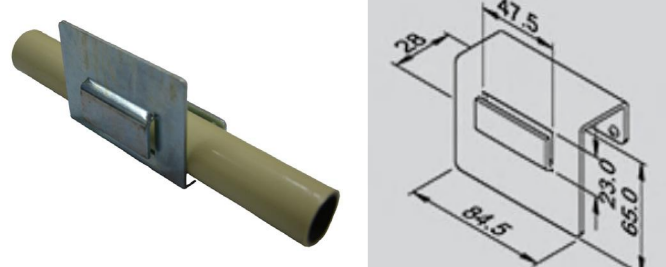

WA-HK200

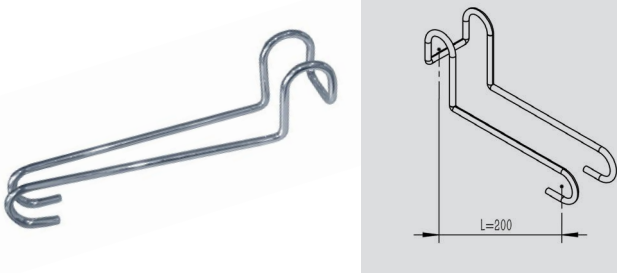

WA-HK300

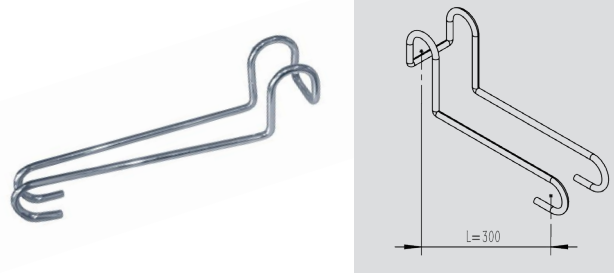

WA-HK400

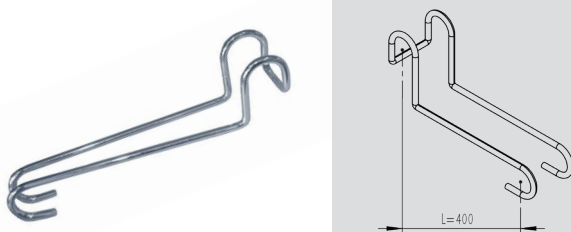

WA-AD1

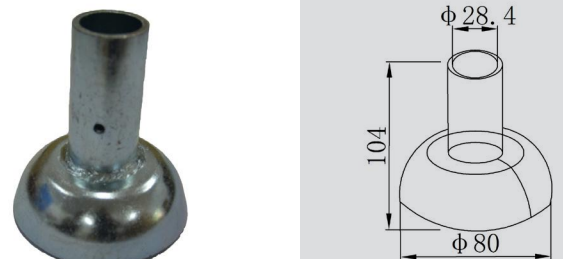

METAL ACCESSORIES 五金配件

WA-AD2

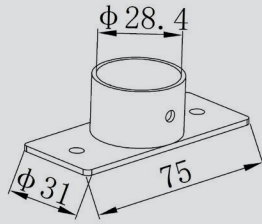

WA-AD3

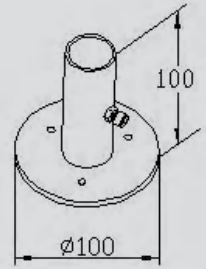

WA-AD4

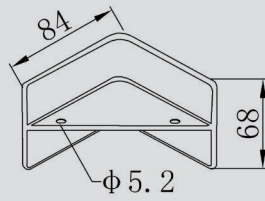

PLASTIC FOOT COVER 塑料脚套



CAP 封盖

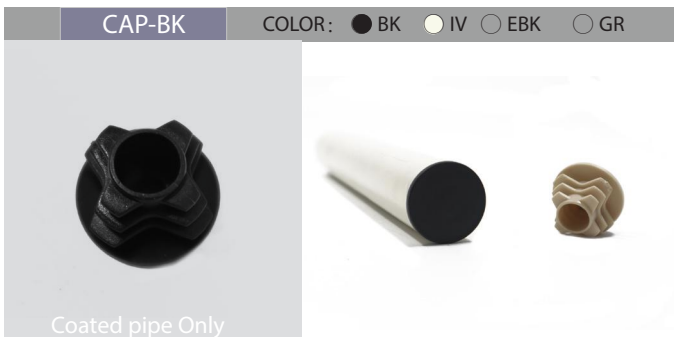

## BOLT AND NUT 螺丝螺母

TYPE 类型	PART NO 型号	ITEM 名称	SPEC 规格	COLOR 颜色	USAGE 搭配使用
	TN06B	T-NUT	M6	BLACK	METAL JOINT
	TN06W		M6	ZINC	
	NN08W	NYLON NUT	M8	ZINC	M8 BOLT
	N08W	NUT	M8	ZINC	M8 BOLT
	PW08W	FLAT WASHER	M8	ZINC	M8 BOLT
	B0610B	M6X10	M6	BLACK	METAL JOINT
	B0610W	M6X10	M6	ZINC	
	B0625B	M6X25	M6	BLACK	
	B0625W	M6X25	M6	ZINC	
	B0628B	M6X28	M6	BLACK	
	B0628W	M6X28	M6	ZINC	
	B0630B	M6X30	M6	BLACK	
	B0630W	M6X30	M6	ZINC	
	B0835W	M8X35	M8	WHITE	CASTER
	B0840W	M8X40	M8	WHITE	
	B0850W	M8X50	M8	WHITE	
	BH0625B	M6X25	M6	BLACK	METAL JOINT
	BH0625W	M6X25	M6	ZINC	
	BH0628B	M6X28	M6	BLACK	
	BH0628W	M6X28	M6	ZINC	
	BH0630B	M6X30	M6	BLACK	
	BH0630W	M6X30	M6	ZINC	



APPLICATION 应用案例



001 不锈钢流利货架



002 移动式物料架

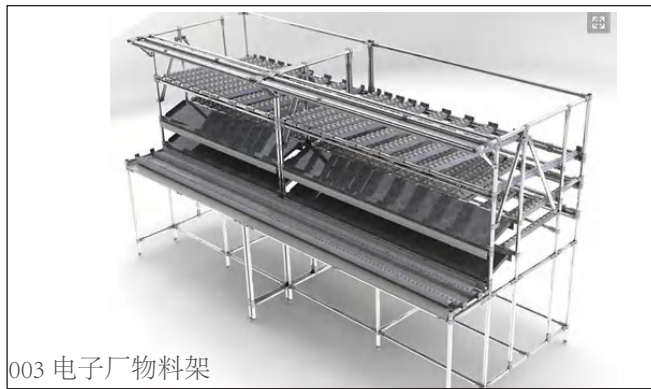

003 电子厂物料架

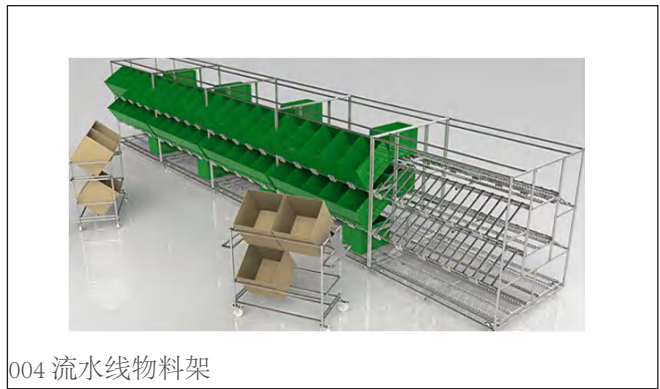

004 流水线物料架



005 电商打包台

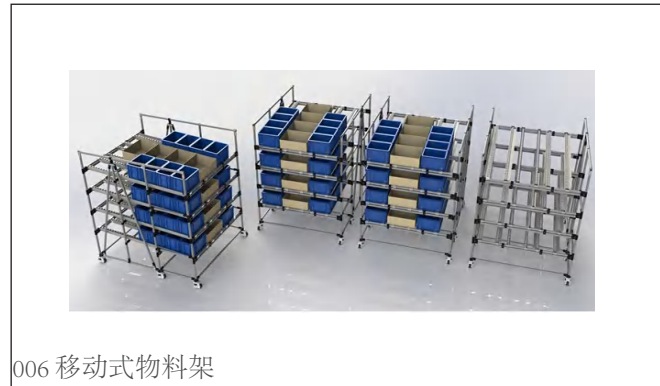

006 移动式物料架

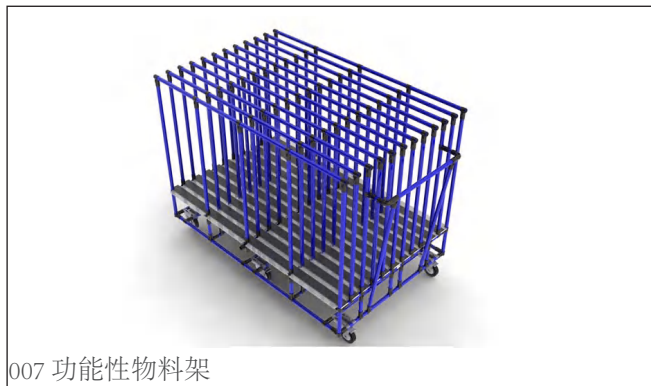

007 功能性物料架

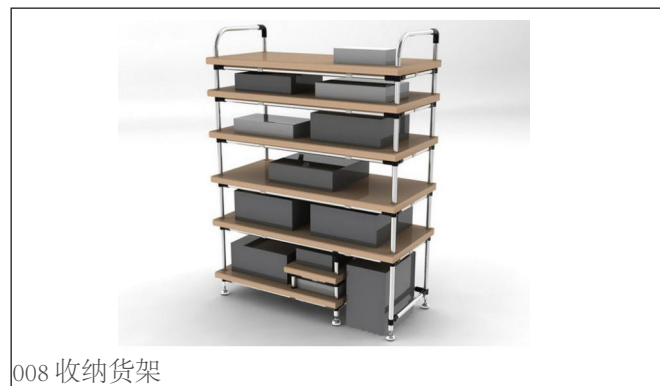

008 收纳货架

APPLICATION 应用案例



009 防静电手推车



010 双层手推车



011 工作台



012 流水线工作台



013 移动式货架



014 标准工作台



015 标准工作台



016 面具货架

# APPLICATION 应用案例

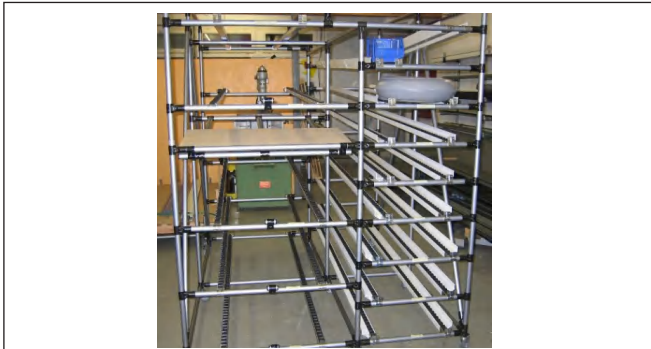

017 打包台货架



018 货架



019 工作台



020 物料架



021 物料架



022 物料架



023 物料架



024 精益管货架



### BENDING STRENGTH FOR ROLLER TRACK

Unit :kgf

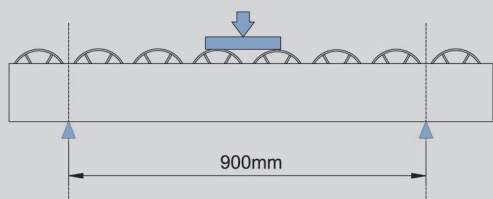

**Test Condition**

1. Test Speed : 5mm / min
2. Temperature : 23℃

Model	Load
35 Series	80
40 Series	150
60 Series	100
70 Series	200
85 Series	300

### COMPRESSION STRENGTH OF WHEEL SUBASSEMBLY

Unit :kgf

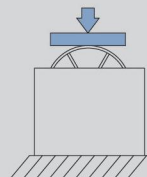

**Test Condition**

1. Test Speed : 5mm / min
2. Temperature : 23℃

Model	Load
35 Series	100
40 Series	150
60 Series	200
70 Series	200
85 Series	300

### ANGLE RECOMMENDED FOR CONSISTENT

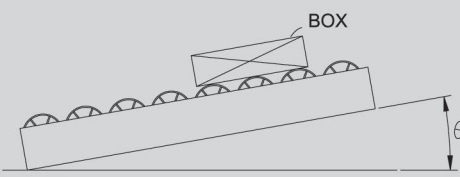

**Test Condition**

1. Box Weight : 0.75kg
2. Temperature : 23℃

Model	Angle( $\theta$ )
35 Series	1.45
40 Series	1.66
60 Series	1.62
70 Series	1.58
85 Series	1.38

### BENDING STRENGTH FOR PIPE

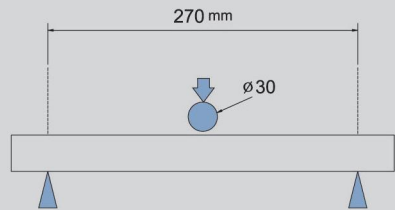

**Test Condition**

1. Test Speed : 5mm / min
2. Temperature : 23℃

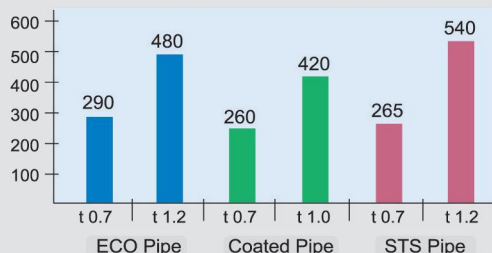

Spec. of Pipe	Eco Pipe	Coated Pipe	STS Pipe
∅ 28×t 0.7	290	260	265
∅ 28×t 1.0	-	420	-
∅ 28×t 1.2	480	-	540



## HOLDING FORCE

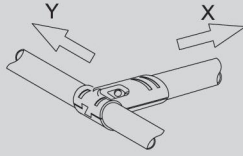

### Test Condition

1. Test Speed : 5mm / min
2. Temperature : 23°C

Classification	Coated Pipe		Stainless Steel Pipe	
	Ø28 x t0.7	Ø28 x t1.0	Ø28 x t0.7	Ø28 x t1.2
Direction : X	More Than 80kg	More Than 80kg	More Than 80 kg	More Than 80 kg
Direction : Y	More Than 80kg	More Than 80kg	More Than 80 kg	More Than 80 kg

## DETERMINING STANDARD PIPE LENGTH

### | Metal Joint |

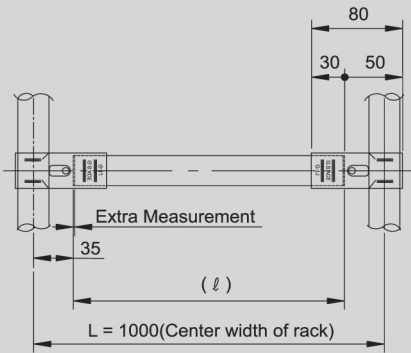

$$\ell = 1000 - (70+2) = 928(\text{mm})$$

#### Case of Ø28mm

1000mm	Center Measurement (L)
-70mm	Pipe Length Inside Joint (35mm x 2)
-2mm	Extra Measurement (2mm~5mm)
928mm	Pipe Length ( ℓ )

### | Plastic Joint |

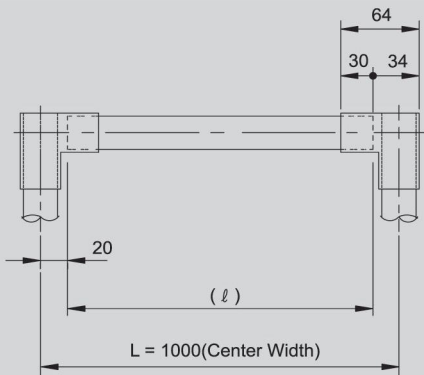









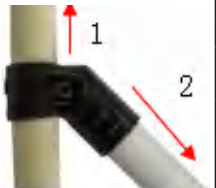

$$\ell = 1000 - (40+2) = 958(\text{mm})$$

#### Case of Ø28mm

1000mm	Center Measurement (L)
-40mm	Pipe Length Inside Joint (20mm x 2)
-2mm	Extra Measurement (2mm~5mm)
958mm	Pipe Length ( ℓ )

Photo	Test photo	Screw torque test photo	NO	Standard Test Data			My company
				Length drawing (mm)	Drawing Speed (mm/min)	Screw strength (N.M)	Drawing strength (kgf)
			1	10	50	10	85.5
						15	126.3
			2			10	167.8
						15	243.8
			1	10	20	10	80.2
						15	98.0
			2			10	91.0
						15	114.0
			3			10	132.4
						15	167.7
			1	10	50	10	280.0
						15	364.0
			2			10	116.0
						15	134.0
			3			10	105.0
						15	135.0
			4			10	98.0
						15	98.0
			1	10	50	10	282.0
						15	310.0
			2			10	71.0
						15	110.0
			3			10	87.0
						15	95.0
			1	10	10	9	77.0
			2			9	57.0

Photo	Test photo	Screw torque test photo	NO	Standard Test Data			My company
				Length drawing (mm)	Drawing Speed (mm/min)	Screw strength (N.M)	Drawing strength (kgf)
			1	10	50	10	21.0
						15	56.0
			2			10	150.0
						15	108.0
			1	10	50	10	163.0
						15	136.0
			2			10	107.0
						15	107.0
			1	10	50	9	79.0
			1	10	50	10	37.0
						15	32.0
			2			10	29.0
						15	60.0





E-mail: [info@wj-lean.com](mailto:info@wj-lean.com)  
<http://www.wj-lean.com>  
<http://www.lean-industech.com>

---

### 东莞总部

Dongguan Headquarter

地址: 东莞市大岭山镇连圩工业路3号

Address: No.3, Lianwei Industrial Road, Dalingshan Town, Dongguan City, Guangdong Province

电话(Tel): (86) 769 8188 2709

---

### 深圳分部

Shenzhen Branch

地址: 深圳市宝安区松岗镇松明大道星河雅苑503室

Address: 503room Xinghe Yayuan, Songming Avenue, Songgang Town, Baoan District, Shenzhen

电话(Tel): (86) 755 3394 0262

---

### 岳阳分部

Yueyang Branch

地址: 湖南省岳阳市岳阳楼区望岳路向东100米

Address: 100 meters east of Wangyue Road, Yueyang Lou District, Yueyang City, Hunan Province

电话(Tel): (86) 730 8516 771

---