



扫一扫关注唯杰精益

## 唯杰自动化设备科技(东莞市)有限公司

WJ-LEAN TECHNOLOGY COMPANY LIMITED

### 东莞总部 DONGGUAN HEADQUARTER

地址：东莞市大岭山镇石大路大岭山段609号

Address: No. 609, Dalingshan Section, Shida Road, Dalingshan Town, Dongguan City, Guangdong Province, China

电话 (Tel) : (86)0769-81882709

## 深圳市杰尤精密压铸科技有限公司

SHENZHEN JIEYOU PRECISION DIE CASTING TECHNOLOGY CO., LTD

### 深圳分部 SHENZHEN BRANCH

地址：深圳市宝安区松岗镇松明大道星河雅苑503室

Address: 503 Room Xinghe Yayuan, Songming Avenue, Songgang Town, Baoan District, Shenzhen China

电话 (Tel) : (86)0755-33940262



November 2023年11月



ALUMINUM  
TUBE SYSTEM  
KARAKURI SYSTEM  
**铝管系列**  
简易自动化方案

唯杰自动化设备科技(东莞市)有限公司  
WJ-LEAN TECHNOLOGY COMPANY LIMITED

# 目录

# CONTENTS

**唯杰精益** WJ-LEAN TECHNOLOGY COMPANY LIMITED

唯杰自动化设备科技有限公司是一家专注于工业建设及其技术解决方案的有限公司。公司总部位于广东东莞，市场布局覆盖全球，在全球多个国家设有综合服务机构。产品广泛应用于机械框架结构及各类零件连接，工业流水线和传送带，小型机动设备及非标机电设备，工业检验检测及安全防护设备。包含电子、汽车零部件装配生产线，家电、化工、家具广告、医疗食品、清洁设备等领域。直至2020年，唯杰已向全世界提供超过上千种产品。

我们使用高度可调节机制和执行器以及其他必要的解决方案来交付功能齐全的产品。公司具备所有的行业产品系统，包括不限于MB工业铝型材装配系统，精益生产系统、线性模组系统、工作台系统及小型梯建平台系统。为精益生产自动化、人体工学和未来智能制造提供先进的解决方案。

WJ-LEAN Technology Company Limited is a focusing on industrial construction and its technical solutions. The company is headquartered in Dongguan, Guangdong, with a global market layout and comprehensive service agencies in many countries. Products are widely used in mechanical frame structure and various parts connection, industrial assembly line and conveyor belt, small motor equipment and non-standard mechanical and electrical equipment, industrial inspection and testing and safety protection equipment. Including electronics, auto parts assembly lines, home appliances, chemicals, furniture advertising, medical food, cleaning equipment and other fields. By 2020, WJ-LEAN has provided more than a thousand products to the world.

We use highly adjustable mechanisms and actuators as well as other necessary solutions to deliver fully functional products. The company has all industry product systems, including but not limited to MB industrial aluminum profile assembly system, lean production.



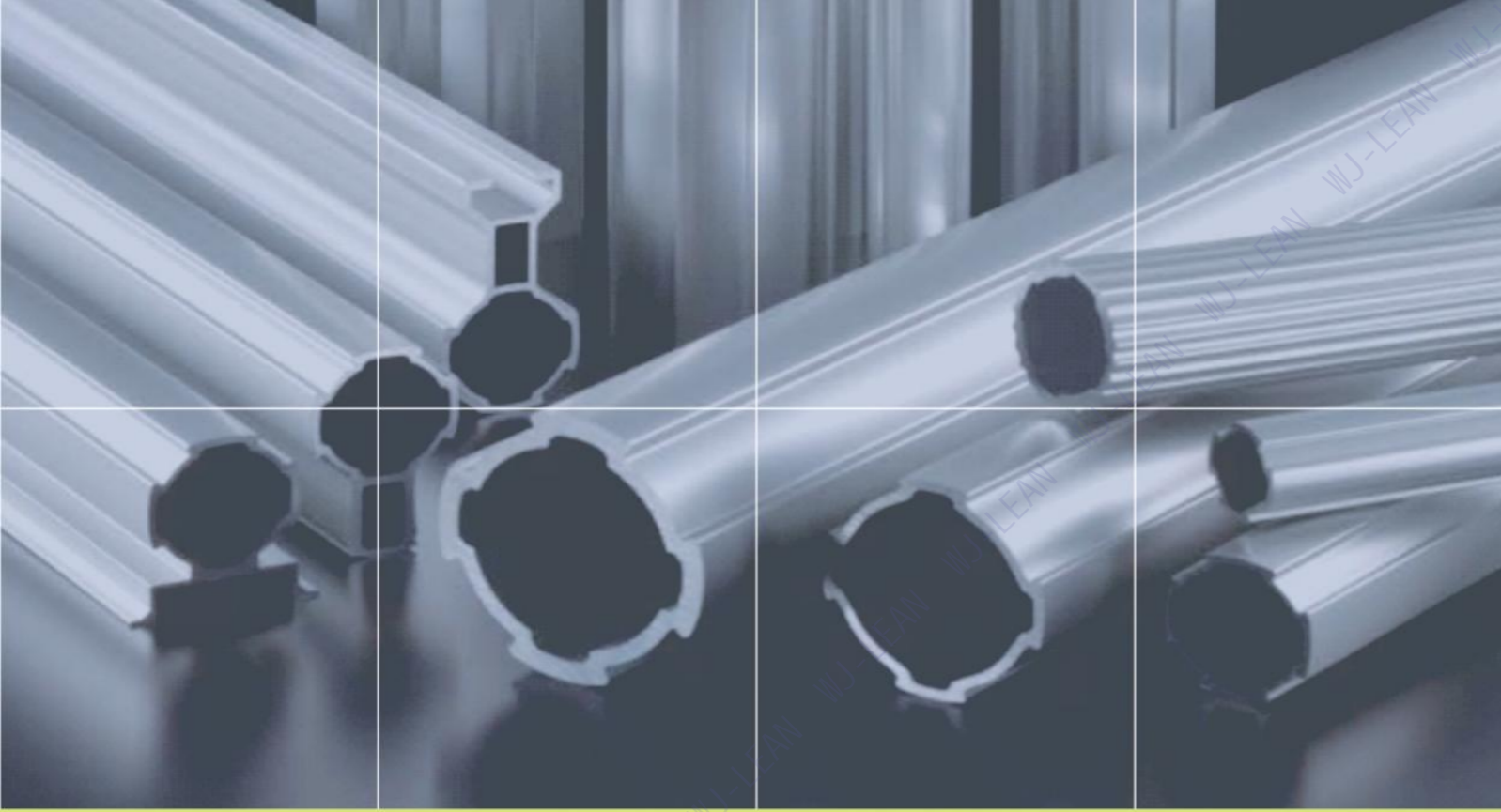

<b>01</b>	<b>ALUMINUM PIPE</b> 铝管	<b>03</b>
<b>02</b>	<b>PLASTIC CAP</b> 塑胶封盖	<b>09</b>
<b>03</b>	<b>ALUMINUM JOINT</b> 铝接头	<b>12</b>
<b>04</b>	<b>CASTER</b> 脚轮	<b>26</b>
<b>05</b>	<b>ALUMINUM ROLLER TRACKS</b> 铝滑轨	<b>31</b>
<b>06</b>	<b>ADJUST ACCESSORY TYPE</b> 脚杯附件类	<b>33</b>
<b>07</b>	<b>MOVABLE ACCESSORIES</b> 可动类配件	<b>38</b>
<b>08</b>	<b>ACCESSORY FOR ALUMINUM TUBE</b> 铝管附件	<b>52</b>
<b>09</b>	<b>PLASTIC GUIDE</b> 塑胶条	<b>55</b>
<b>10</b>	<b>19 SERIES</b> 19系列	<b>59</b>
<b>11</b>	<b>43 SERIES</b> 43系列	<b>64</b>
<b>12</b>	<b>TECHNICAL DATA</b> 技术数据	<b>67</b>











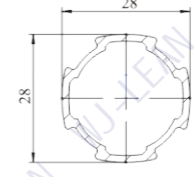

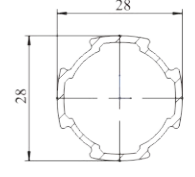
# 01 ALUMINUM PIPE

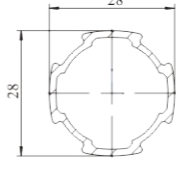
## 鋁管

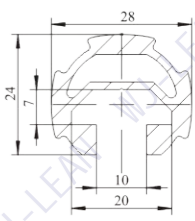
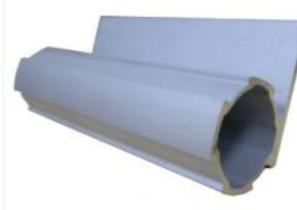
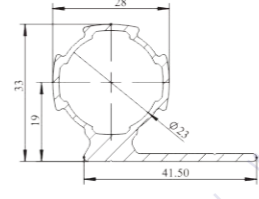
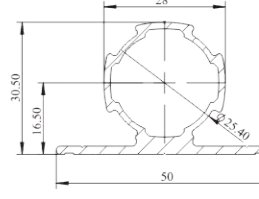
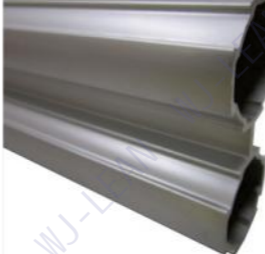
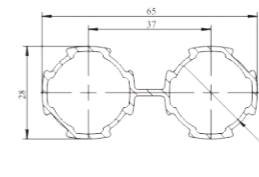
Series系列	Roller Color颜色	Material材质	Length长度
 28mm series	 SL silve 银白	6063T5 ESD 防静电	Standard Length: L=4000mm Or L=6000mm  Other Lengths Can Also Be Customized, Moq=1000pcs
	 YE yellow 黄色		
	 BK black 黑色		

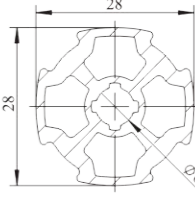
Tube 常见款	AP-28A-1.2	AP-28A-1.5	AP-28A-1.7	AP-28B	AP-28C	AP-28D	AP-28E	AP-28F
	  <p>T=1.2</p> <p>Material 6063T5 Weight 0.34kg/m Length 4/6 Meters</p>	  <p>T=1.5</p> <p>Material 6063T5 Weight 0.42kg/m Length 4/6 Meters</p>	  <p>T=1.7</p> <p>Material 6063T5 Weight 0.45kg/m Length 4/6 Meters</p>	  <p>Material 6063T5 Weight 0.72kg/m Length 4/6 Meters</p>	  <p>Material 6063T5 Weight 0.65kg/m Length 4/6 Meters</p>	  <p>Material 6063T5 Weight 0.57kg/m Length 4/6 Meters</p>	  <p>Material 6063T5 Weight 0.66kg/m Length 4/6 Meters</p>	  <p>Material 6063T5 Weight 0.67kg/m Length 4/6 Meters</p>

Tube 常见款

**AP-28G** SL

Material: 6063T5  
Weight: 0.72kg/m  
Length: 4/6 Meters

**AP-28H** SL

Material: 6063T5  
Weight: 0.4kg/m  
Length: 4/6 Meters

**AP-28I** SL

Material: 6063T5  
Weight: 0.5kg/m  
Length: 4/6 Meters

**AP-28J** SL

Material: 6063T5  
Weight: 1.02kg/m  
Length: 4/6 Meters

**AP-28K** SL

Material: 6063T5  
Weight: 0.53kg/m  
Length: 4/6 Meters

Tube 常见款

**AP-28L1** SL T=1.0MM

Material: 6063T5  
Weight: 0.379kg/m  
Length: 4/6 Meters

**AP-28L2** SL T=1.2MM

Material: 6063T5  
Weight: 0.446kg/m  
Length: 4/6 Meters

**AP-28L3** SL T=2.0MM

Material: 6063T5  
Weight: 0.49kg/m  
Length: 4/6 Meters

**AP-28M** SL

Material: 6063T5  
Weight: 0.37kg/m  
Length: 4/6 Meters

**AP-28N** SL

Material: 6063T5  
Weight: 0.48kg/m  
Length: 4/6 Meters



Profile 型材类

**AF-001** SL

Material 6063T5  
Weight 0.46kg/m  
Length 4/6 Meters

**AF-002** SL

Material 6063T5  
Weight 0.62kg/m  
Length 4/6 Meters

**AF-003** SL

Material 6063T5  
Weight 1.85 kg/m  
Length 4/6 Meters

**AF-004** SL

Material 6063T5  
Weight 1.49kg/m  
Length 4/6 Meters

**AF-005A** SL

Material 6063T5  
Weight 1.95kg/m  
Length 4/6 Meters

**AF-005B** SL

Material 6063T5  
Weight 1.49kg/m  
Length 4/6 Meters

Profile 型材类

**AF-006** SL

Material 6063T5  
Weight 0.46kg/m  
Length 4/6 Meters

**AF-007** SL

Material 6063T5  
Weight 0.2kg/m  
Length 4/6 Meters

**AF-008** SL

Material 6063T5  
Weight 0.32kg/m  
Length 4/6 Meters

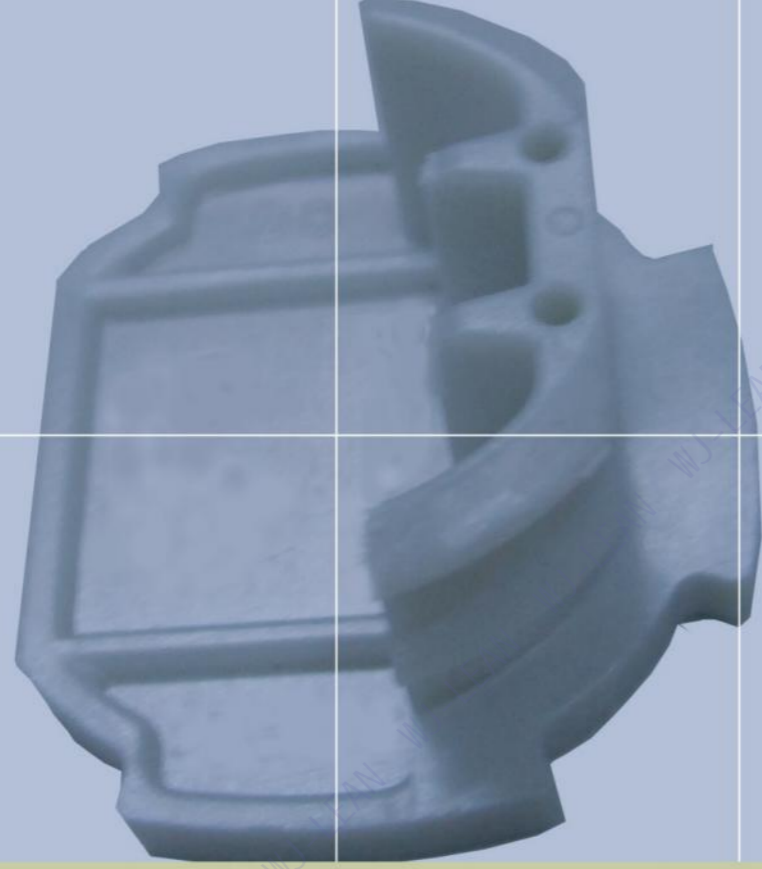

# 02 PLASTIC CAP

## 塑膠封蓋

Roller Color颜色
<span style="color: red;">●</span> EB ESD BLACK防静电黑
<span style="color: gray;">●</span> GR GRAY灰色
<span style="color: black;">●</span> BK BLACK黑色

Material材质
plastic 塑胶

Plastic Cap 塑胶封盖

**28C-1A** ● EB ● GR ● BK

Weight 0.003 kg Package 1000 pcs

**28C-1B** ● EB ● GR ● BK

Weight 0.002 kg Package 1000 pcs

**28C-2A** ● EB ● GR ● BK

Weight 0.005 kg Package 500 pcs

**28C-2B (ADP1)** ● EB ● GR ● BK

Weight 0.018 kg Package 200 pcs

**28C-3** ● EB ● GR ● BK

Weight 0.003 kg Package 500 pcs

**28C-4** ● EB ● GR ● BK

Weight 0.001 kg Package 2000 pcs

**28C-5A** ● EB ● GR ● BK

Weight 0.006 kg Package 1000 pcs

**28C-5B** ● EB ● GR ● BK

Weight 0.008 kg Package 1000 pcs



Plastic Cap 塑胶封盖

**28C-5C** ● EB ● GR ● BK

Weight 0.008 kg Package 1000 pcs

**28C-5D** ● EB ● GR ● BK

Weight 0.008 kg Package 1000 pcs

**28C-6A** ● EB ● GR ● BK

Weight 0.007 kg Package 500 pcs

**28C-6B** ● EB ● GR ● BK

Weight 0.005 kg Package 500 pcs

**28C-7** ● EB ● GR ● BK

Weight 0.006 kg Package 500 pcs



# 03 ALUMINUM JOINT

## 鋁接頭

Series系列	Roller Color颜色	Material材质	Length长度
<p>28mm series</p>	<p>SL silve 银白</p>	6063T5	<p>Extrusion 挤出</p> <hr/> <p>Die-casting 压铸</p>

Aluminum Joint 铝接头

28J-1



Weight 0.056 kg Package 180 pcs

28J-1A-1.2

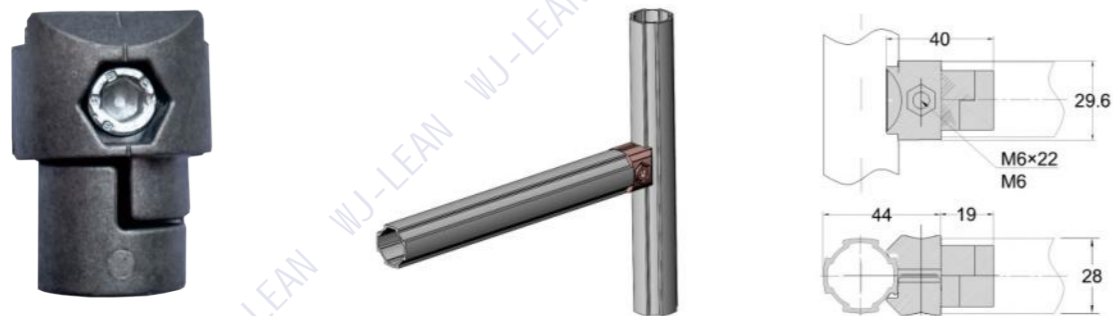

Weight 0.056 kg Package 250 pcs

28J-1A-1.7

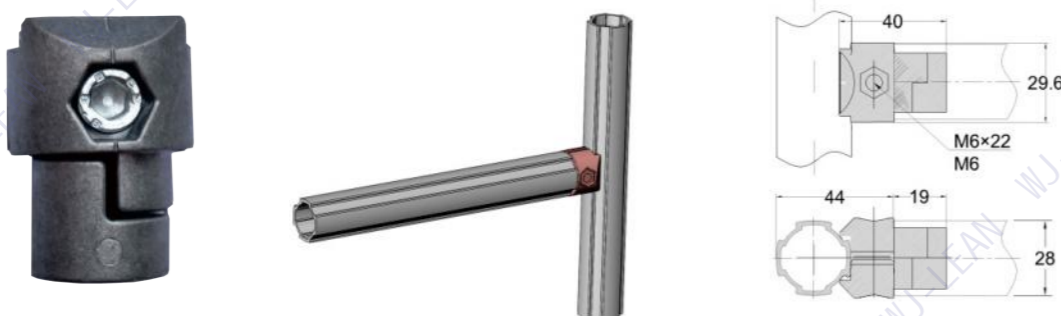

Weight 0.056 kg Package 250 pcs

28J-1B-1.2

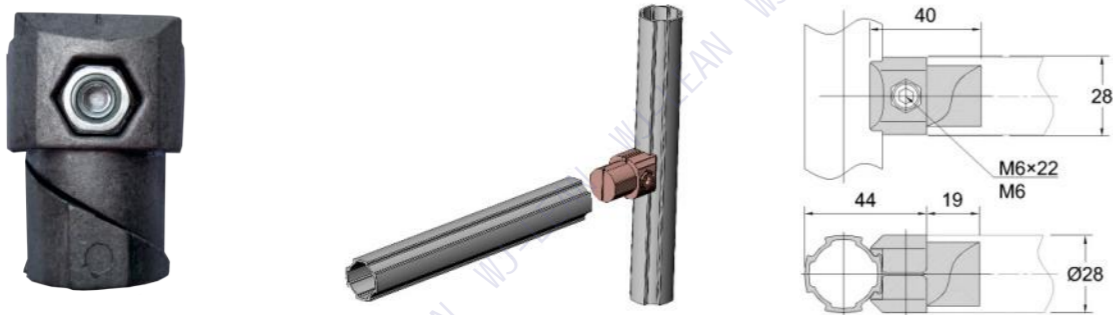

Weight 0.048 kg Package 250 pcs

Aluminum Joint 铝接头

28J-1B-1.7



Weight 0.048 kg Package 250 pcs

28J-2

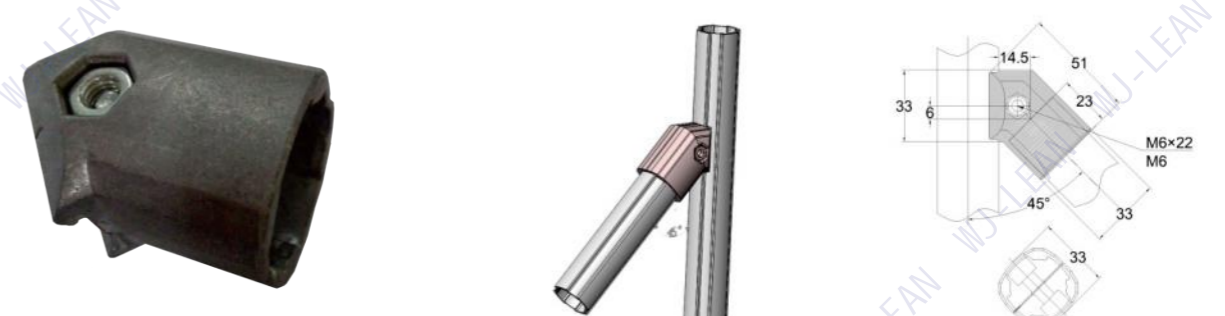

Weight 0.058 kg Package 150 pcs

28J-2A



Weight 0.052 kg Package 250 pcs

28J-3

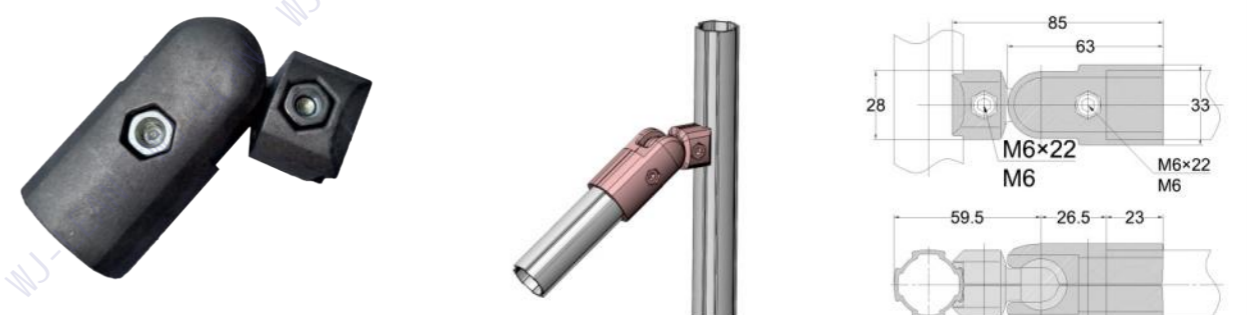

Weight 0.12 kg Package 90 pcs



Aluminum Joint 铝接头

28J-3A

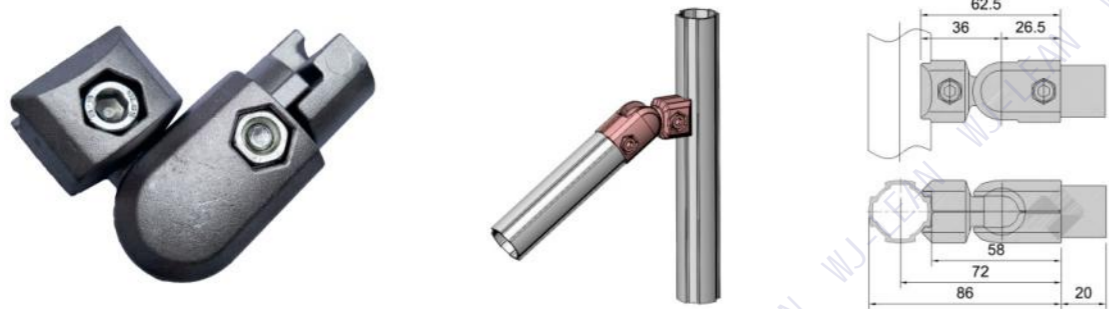

Weight 0.11kg Package 125 pcs

28J-3B



Weight 0.15 kg Package 70 pcs

28J-3C



Weight 0.122 kg Package 120 pcs

28J-4

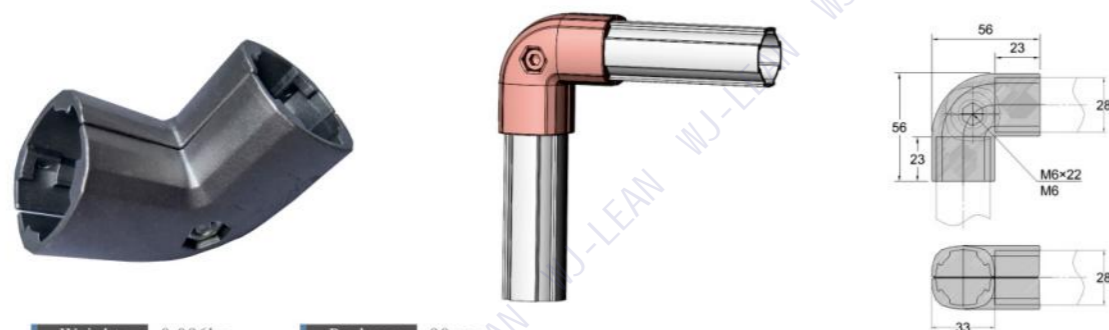

Weight 0.096kg Package 90 pcs

Aluminum Joint 铝接头

28J-4A

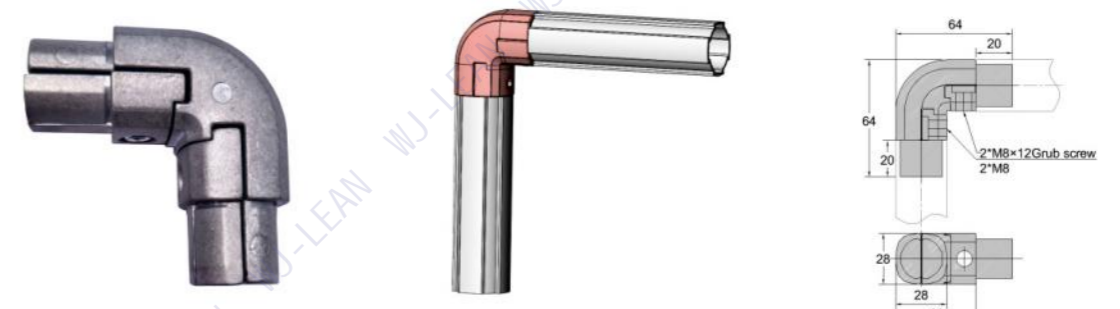

Weight 0.043 kg Package 70 pcs

28J-5

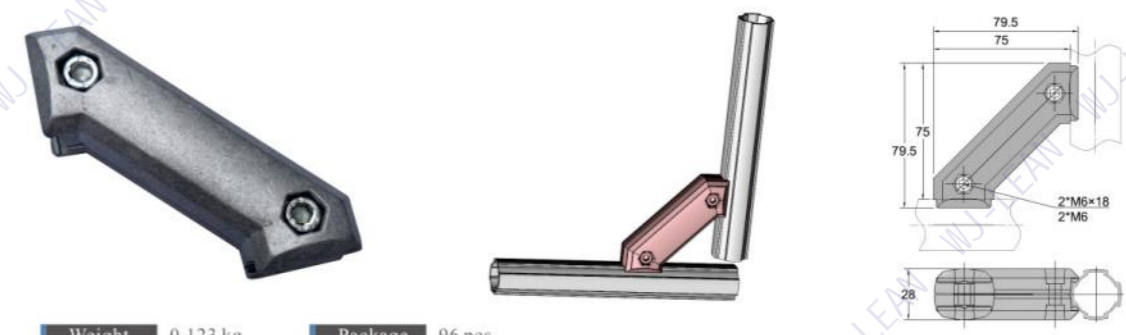

Weight 0.123 kg Package 96 pcs

28J-5A

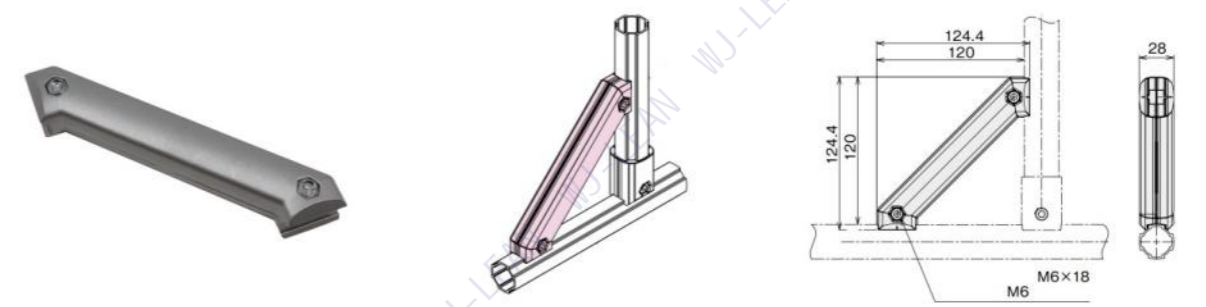

Weight 0.211 kg Package 55 pcs

28J-6

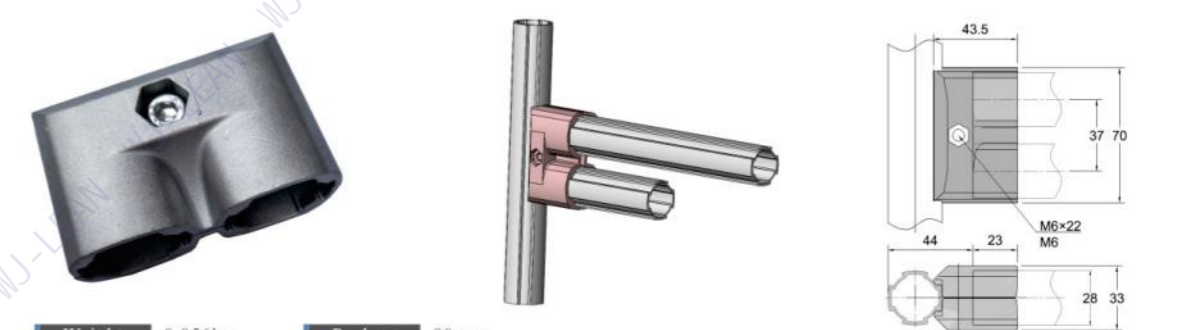

Weight 0.056kg Package 90 pcs

Aluminum Joint 铝接头

28J-7

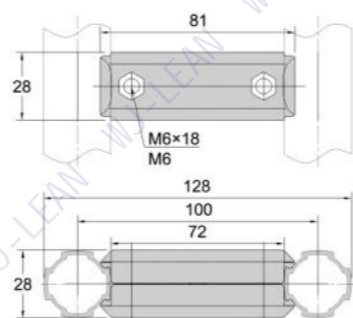

Weight 0.122 kg Package 150 pcs

28J-8

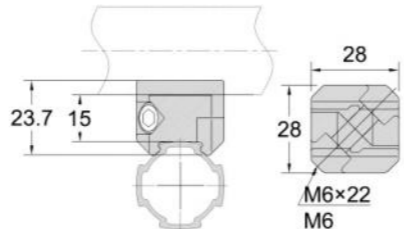
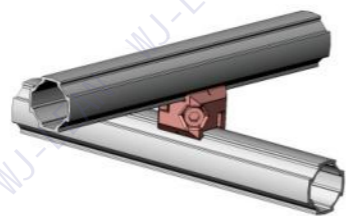

Weight 0.04kg Package 400 pcs

28J-9

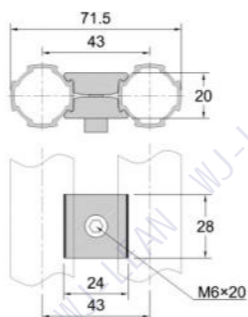
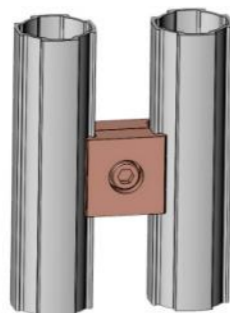
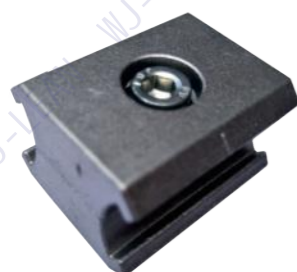

Weight 0.051 kg Package 250 pcs

28J-9A

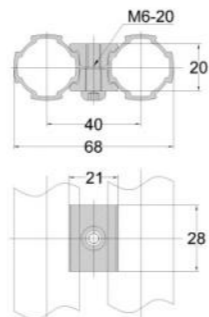
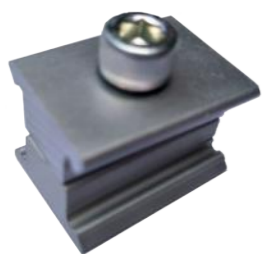

Weight 0.023 kg Package 500 pcs

Aluminum Joint 铝接头

28J-9B

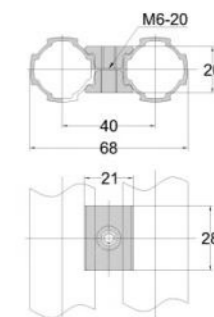
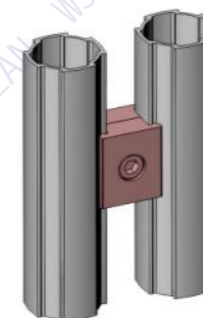

Weight 0.027 kg Package 400 pcs

28J-10

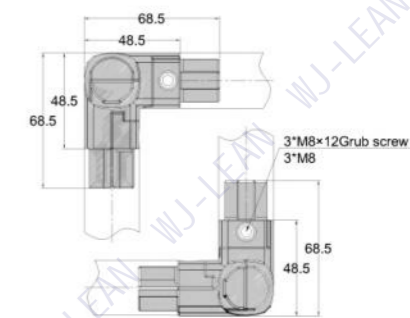
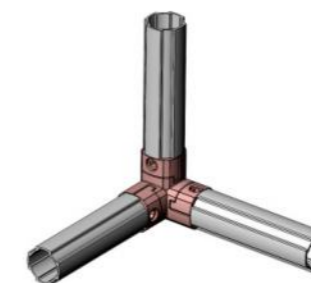

Weight 0.23 kg Package 50 pcs

28J-11

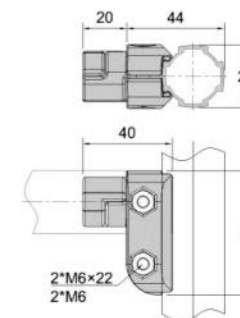
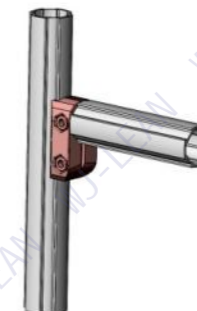

Weight 0.082 kg Package 180 pcs

28J-12

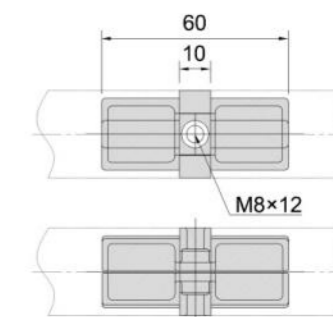

Weight 0.074kg Package 150 pcs



Aluminum Joint 铝接头

28J-13

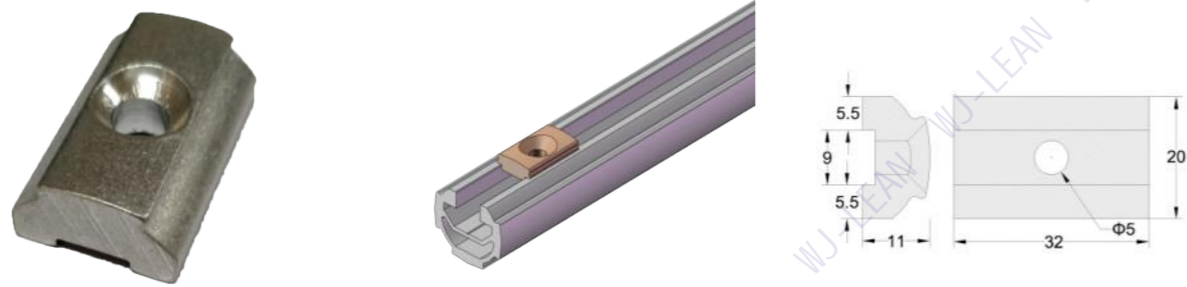

Weight 0.013 kg Package 1000 pcs

28J-13A

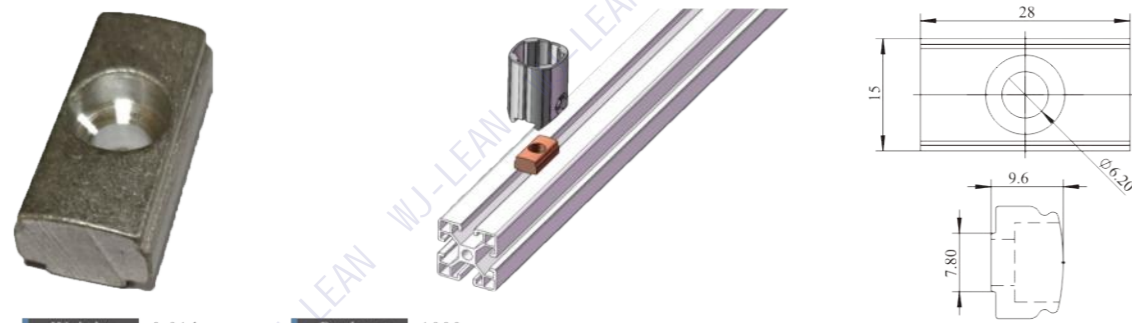

Weight 0.01 kg Package 1000 pcs

28J-13B

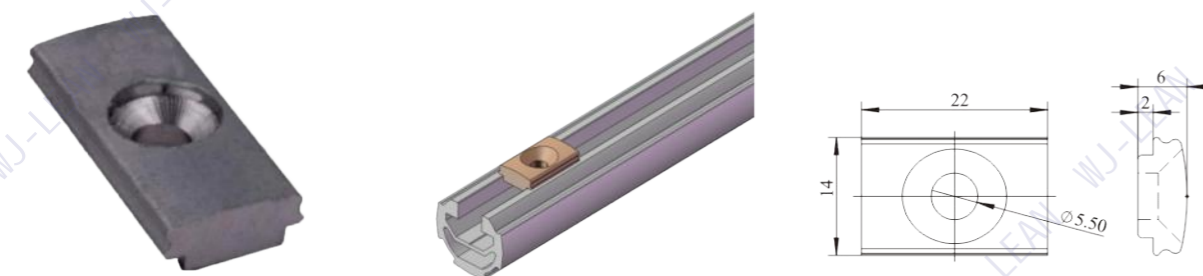

Weight 0.07 kg Package 2000 pcs

28J-14

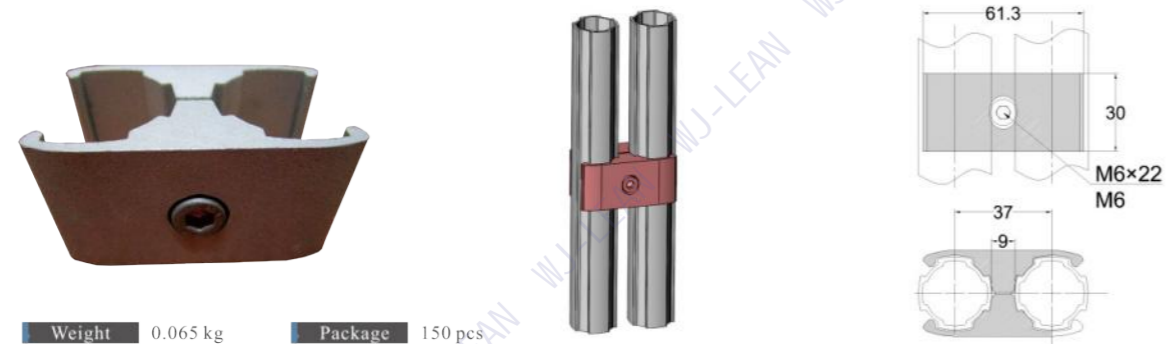

Weight 0.065 kg Package 150 pcs

Aluminum Joint 铝接头

28J-15

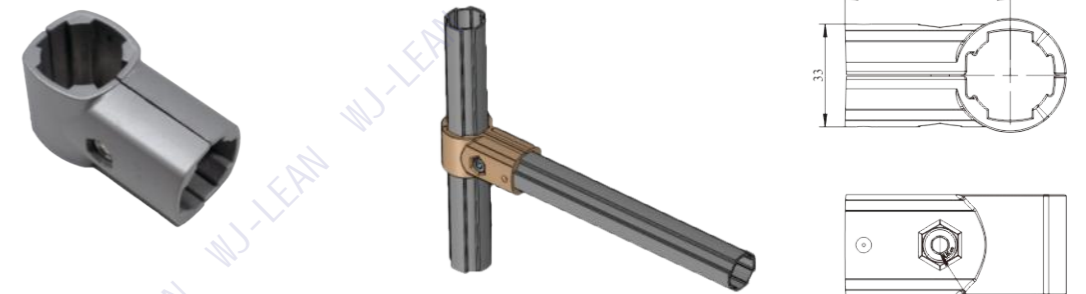

Weight 0.075kg Package 105 pcs

28J-16

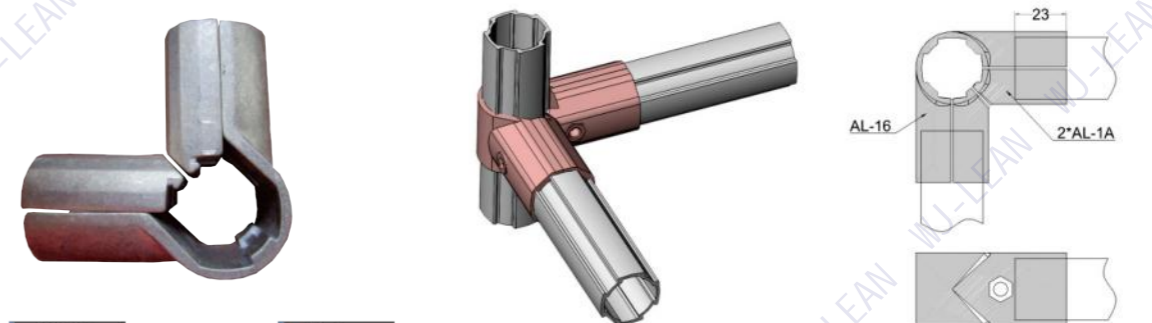

Weight 0.078 kg Package 60 pcs

28J-17

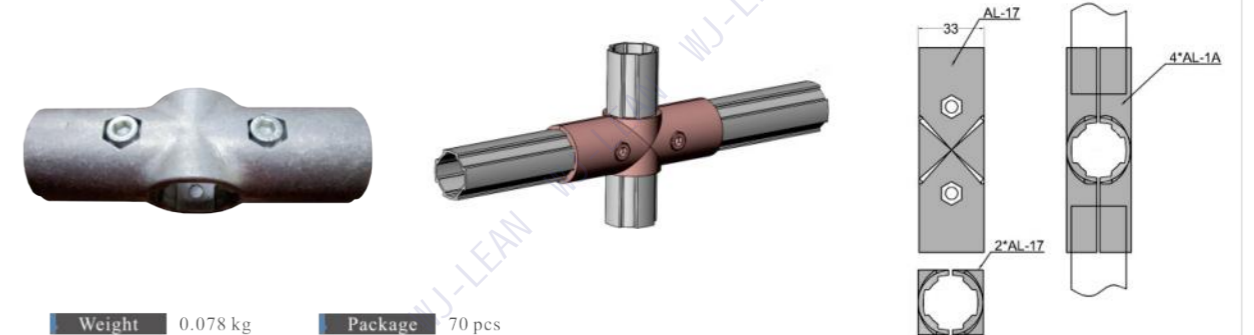

Weight 0.078 kg Package 70 pcs

28J-18



Weight 0.076 kg Package 100 pcs

Aluminum Joint 铝接头

28J-19A



Weight 0.072kg Package 100 pcs

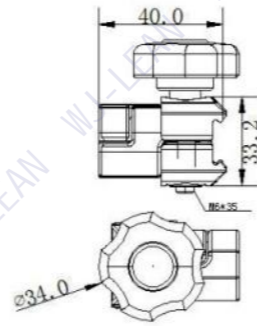
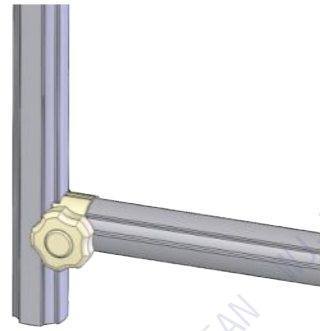

28J-19B



Weight 0.072kg Package 100 pcs

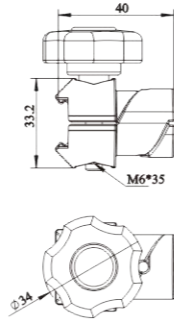
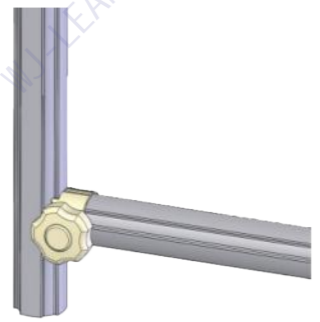

28J-20



Weight 0.037 kg Package 400 pcs

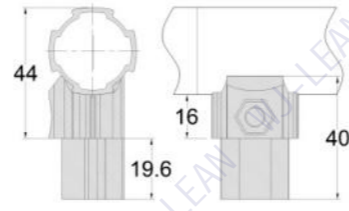

28J-21



Weight 0.024kg Package 500pcs

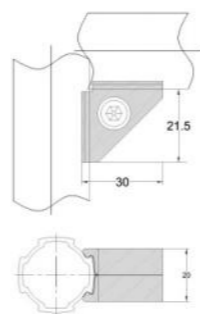
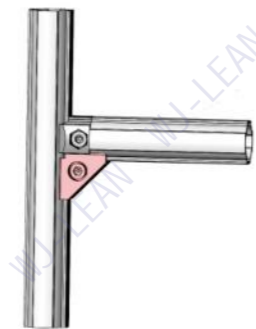

Aluminum Joint 铝接头

28J-22



Weight 0.052kg Package 250pcs

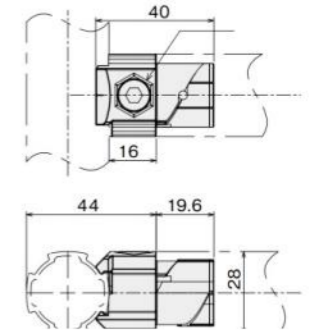
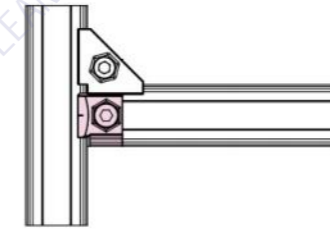

28J-23



Weight 0.07kg Package 100 pcs

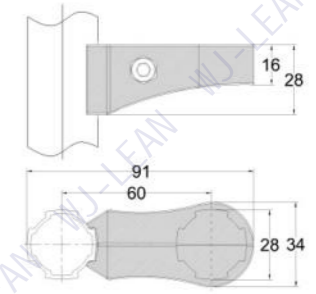
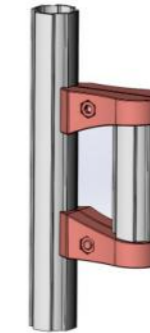

28J-24



Weight 0.13kg Package 150 pcs

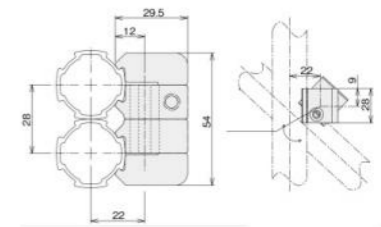
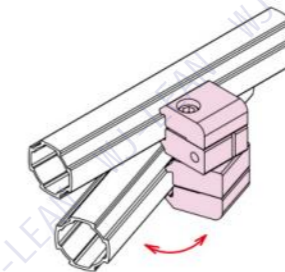

28J-25A-56

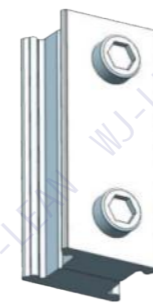

Weight 0.051kg Package 300 pcs

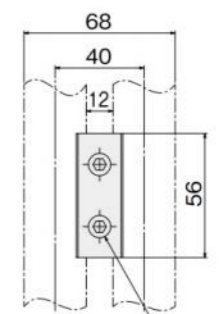
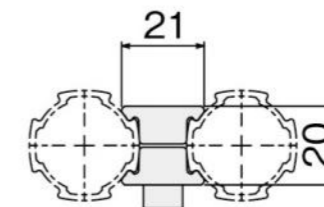

M6x20



Aluminum Joint 铝接头

28J-25A-100

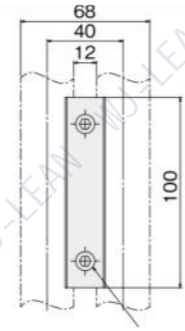
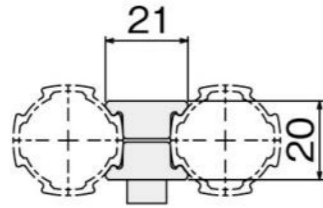

Weight 0.084kg

Package 200 pcs

M6x20

28J-25B-56

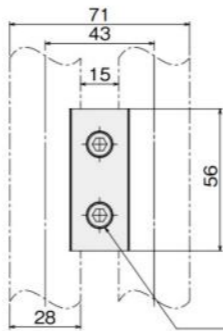
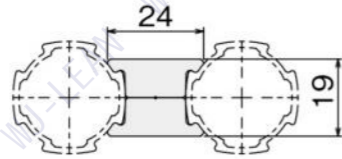

Weight 0.052kg

Package 300 pcs

M6x12

28J-25B-100

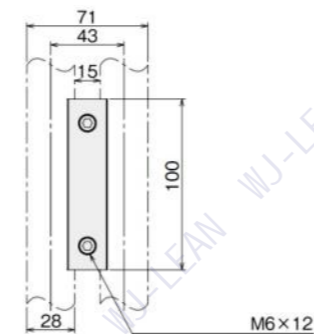
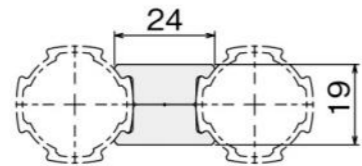
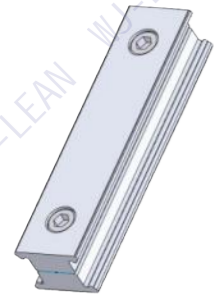

Weight 0.085kg

Package 200 pcs

M6x12

28J-26

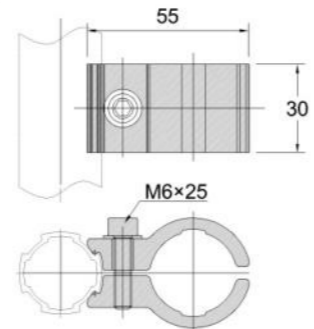
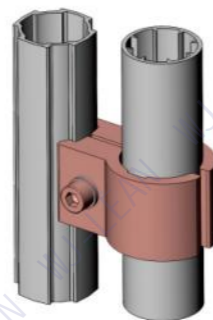

Weight 0.062kg

Package 150 pcs

M6x25

Aluminum Joint 铝接头

28J-27A-50

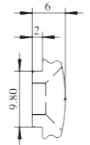
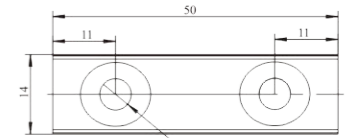
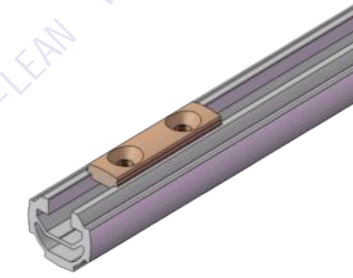
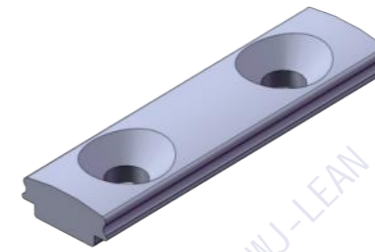

Weight 0.041kg

Package 300 pcs

28J-27A-100

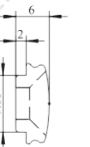
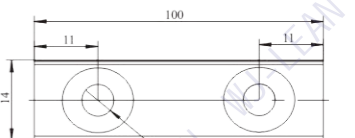
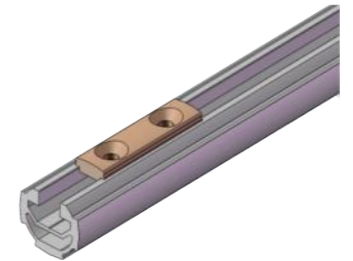

Weight 0.05kg

Package 200 pcs

28J-27B-50

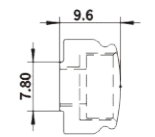
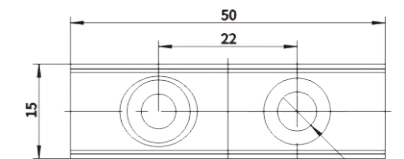
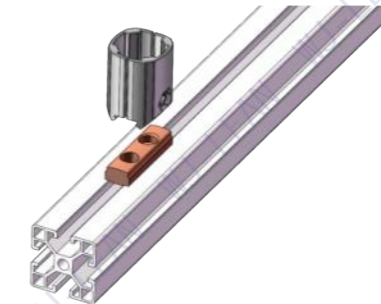
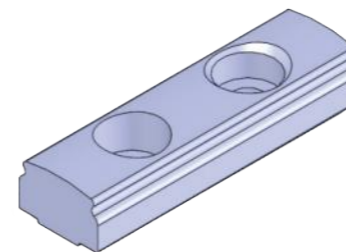

Weight 0.056kg

Package 300 pcs

28J-27B-100

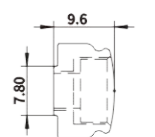
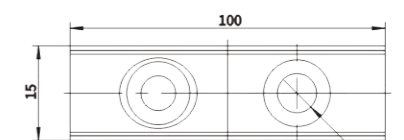
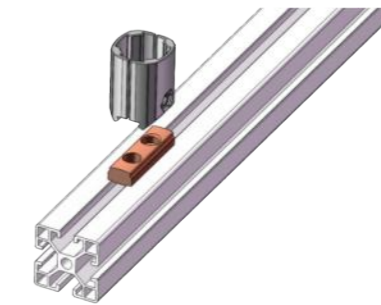

Weight 0.085kg

Package 200 pcs

Aluminum Joint 铝接头

28J-28

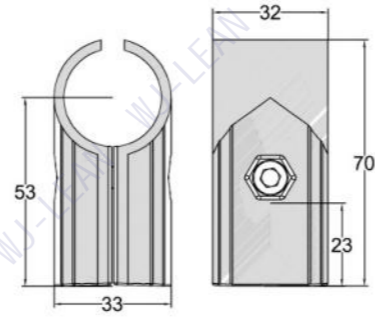
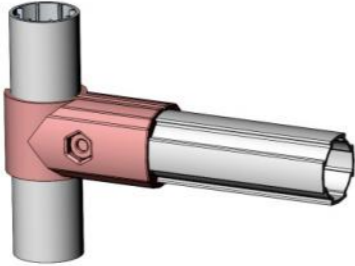

Weight 0.16kg

Package 120 pcs

28J-29

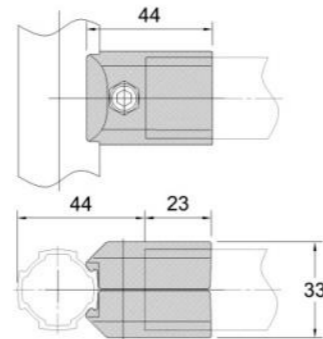
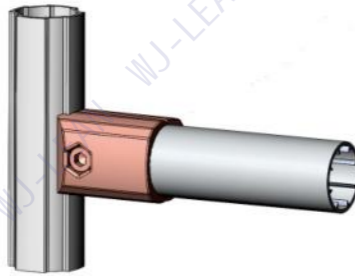

Weight 0.1kg

Package 180pcs

28J-30

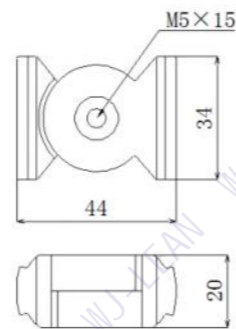

Weight 0.052kg

Package 250pcs

28J-31

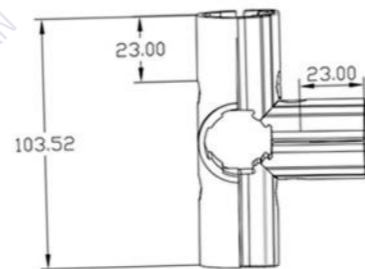

Weight 0.175kg

Package 100pcs

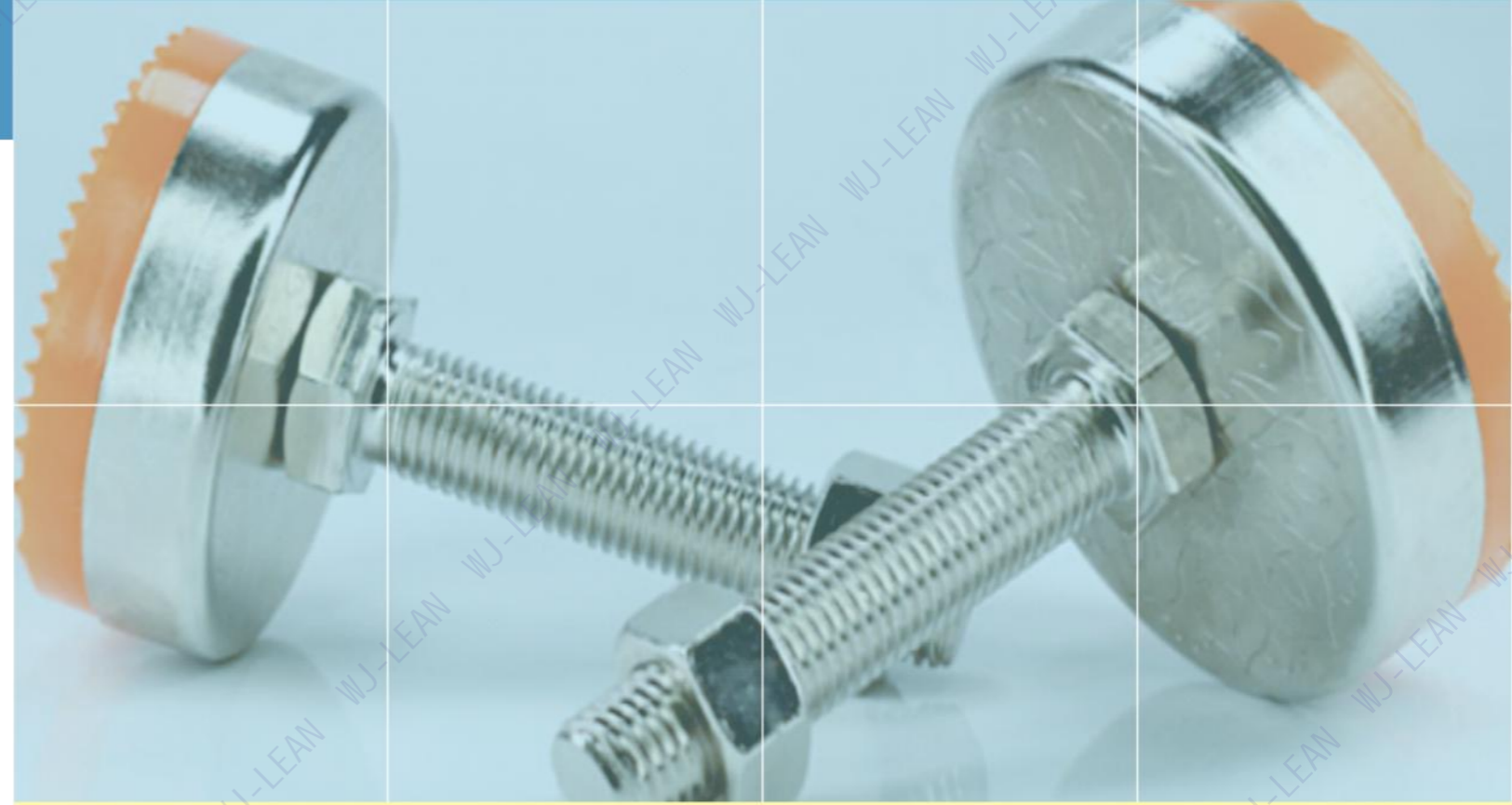

# 04 CASTER

## 脚輪

Series系列	Roller Color颜色	Material材质	Size尺寸	Model explanation 类型说明
Flat plate fixed Series 平板固定式	● RE Red	Wheel material 轮子材质	2" OD=50mm	A Without brake 不带刹车
Insertion Caster Series 插杆式	● BK Black	TPR 热塑性橡胶 PU 聚氨酯 Rubber 橡胶	3" OD=75mm	B brake 刹车
	● GR GRAY			C Fixed 固定式
Bushing Caster Series 丝杆插入式	● EB ESD Black	Frame Material 支架材质	4" OD=100mm	WJ-301A-ESD
	● EG ESD GRAY			WJ-LEAN的简称 WJ=short for WJ-LEAN
		Steel 铁材质	5" OD=125mm	3寸 3=3" 平板固定式 1=Flat plate fixed Series 不带刹车 A=Without brake 防静电轮子 ESD=EAD black wheels



01 Flat plate fixed Series 平板固定脚轮系列

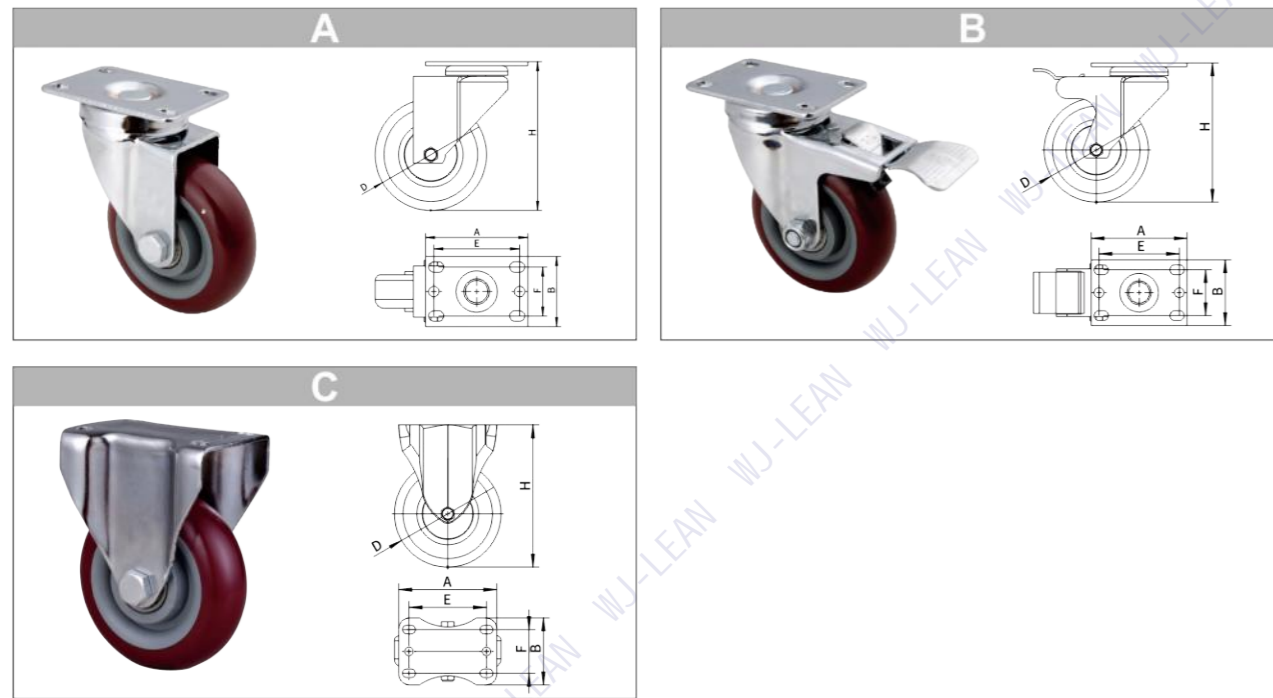

Insertion Caster Series	Wheel Dia (inch)	D 轮径 (mm)	T 丝杆外径	Material 轮子材质	Frame Material 支架材质	Offset Distance PIA 偏心距 (mm)	Loading 承重 (N)	H 高度 (mm)	Weight 单重 (g)	Package 每箱 (pcs)
WJ-301A	3"	75mm	70*60	TPR/PU/Rubber	steel	35	800	95	630	50
WJ-301A-ESD	3"	75mm	70*60	TPR/Rubber	steel	35	800	95	630	50
WJ-301B	3"	75mm	70*60	TPR/PU/Rubber	steel	35	800	95	730	50
WJ-301B-ESD	3"	75mm	70*60	TPR/Rubber	steel	35	800	95	730	50
WJ-301C	3"	75mm	70*60	TPR/PU/Rubber	steel	/	800	95	450	50
WJ-301C-ESD	3"	75mm	70*60	TPR/Rubber	steel	/	800	95	450	50
WJ-401A	4"	100mm	90*100	TPR/PU/Rubber	steel	32	1200	132	740	40
WJ-401A-ESD	4"	100mm	90*100	TPR/Rubber	steel	32	1200	132	740	40
WJ-401B	4"	100mm	90*100	TPR/PU/Rubber	steel	32	1200	132	910	40
WJ-401B-ESD	4"	100mm	90*100	TPR/Rubber	steel	32	1200	132	910	40
WJ-401C	4"	100mm	90*100	TPR/PU/Rubber	steel	/	1200	132	550	40
WJ-401C-ESD	4"	100mm	90*100	TPR/Rubber	steel	/	1200	132	550	40
WJ-501A	5"	125mm	120*110	TPR/PU/Rubber	steel	32	1600	190	900	30
WJ-501A-ESD	5"	125mm	120*110	TPR/Rubber	steel	32	1600	190	900	30
WJ-501B	5"	125mm	120*110	TPR/PU/Rubber	steel	32	1600	190	1050	30
WJ-501B-ESD	5"	125mm	120*110	TPR/PU/Rubber	steel	32	1600	190	1050	30
WJ-501C	5"	125mm	120*110	TPR/Rubber	steel	/	1600	190	750	30
WJ-501C-ESD	5"	125mm	120*110	TPR/PU/Rubber	steel	/	1600	190	750	30

02 Insertion Caster Series 插杆脚轮系列

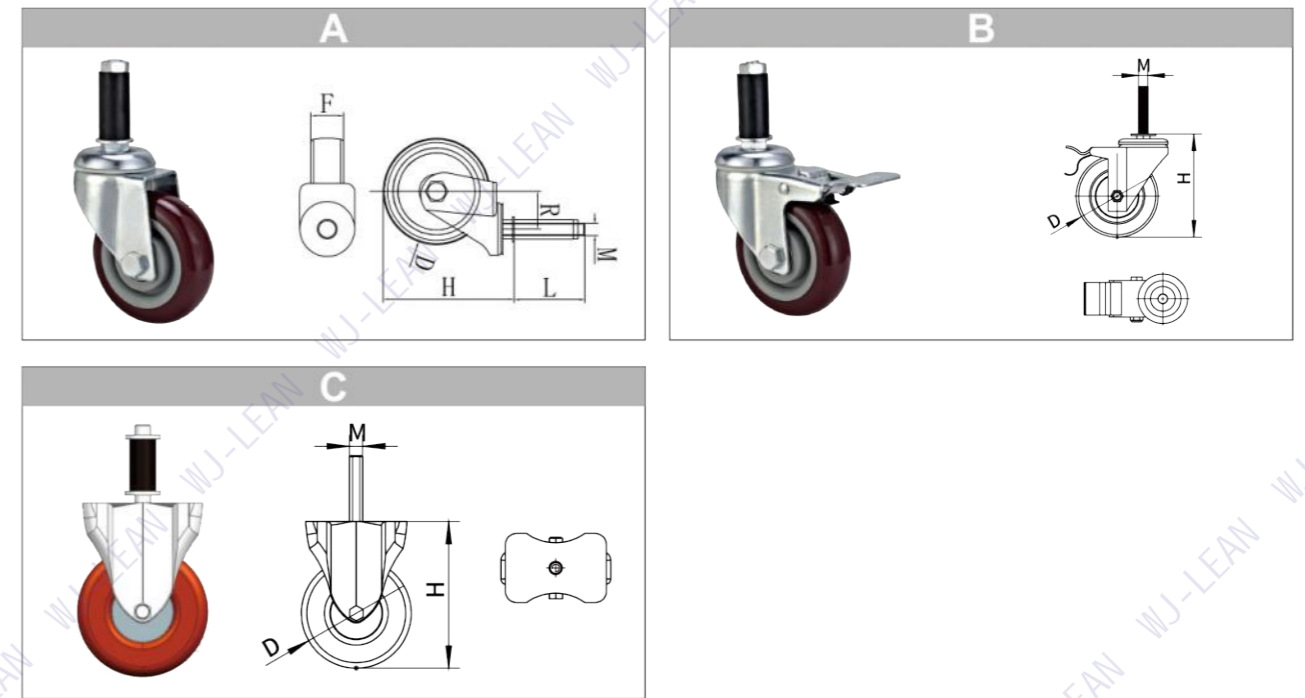

Insertion Caster Series	Wheel Dia (inch)	D 轮径 (mm)	T 丝杆外径	Material 轮子材质	Frame Material 支架材质	Offset Distance PIA 偏心距 (mm)	Loading 承重 (N)	H 高度 (mm)	Weight 单重 (g)	Package 每箱 (pcs)
WJ-202A	2"	50mm	M12*60	TPR/PU/Rubber	steel	22	300	67	280	100
WJ-202A-ESD	2"	50mm	M12*60	TPR/Rubber	steel	22	300	67	280	100
WJ-202B	2"	50mm	M12*60	TPR/PU/Rubber	steel	22	300	67	300	100
WJ-202B-ESD	2"	50mm	M12*60	TPR/Rubber	steel	22	300	67	300	100
WJ-202C	2"	50mm	M12*60	TPR/PU/Rubber	steel	/	300	67	280	100
WJ-202C-ESD	2"	50mm	M12*60	TPR/Rubber	steel	/	300	67	280	100
WJ-302A	3"	75mm	M12*60	TPR/PU/Rubber	steel	35	500	95	480	50
WJ-302A-ESD	3"	75mm	M12*60	TPR/Rubber	steel	35	500	95	480	50
WJ-302B	3"	75mm	M12*60	TPR/PU/Rubber	steel	35	500	95	580	50
WJ-302B-ESD	3"	75mm	M12*60	TPR/Rubber	steel	35	500	95	580	50
WJ-302C	3"	75mm	M12*60	TPR/PU/Rubber	steel	/	500	95	450	50
WJ-302C-ESD	3"	75mm	M12*60	TPR/Rubber	steel	/	500	95	450	50
WJ-402A	4"	100mm	M12*60	TPR/PU/Rubber	steel	32	600	132	630	40
WJ-402A-ESD	4"	100mm	M12*60	TPR/Rubber	steel	32	600	132	630	40
WJ-402B	4"	100mm	M12*60	TPR/PU/Rubber	steel	32	600	132	780	40
WJ-402B-ESD	4"	100mm	M12*60	TPR/Rubber	steel	32	600	132	780	40
WJ-402C	4"	100mm	M12*60	TPR/PU/Rubber	steel	/	600	132	620	40
WJ-402C-ESD	4"	100mm	M12*60	TPR/Rubber	steel	/	600	132	620	40

03 Bushing Caster Series 螺杆插入式脚轮系列

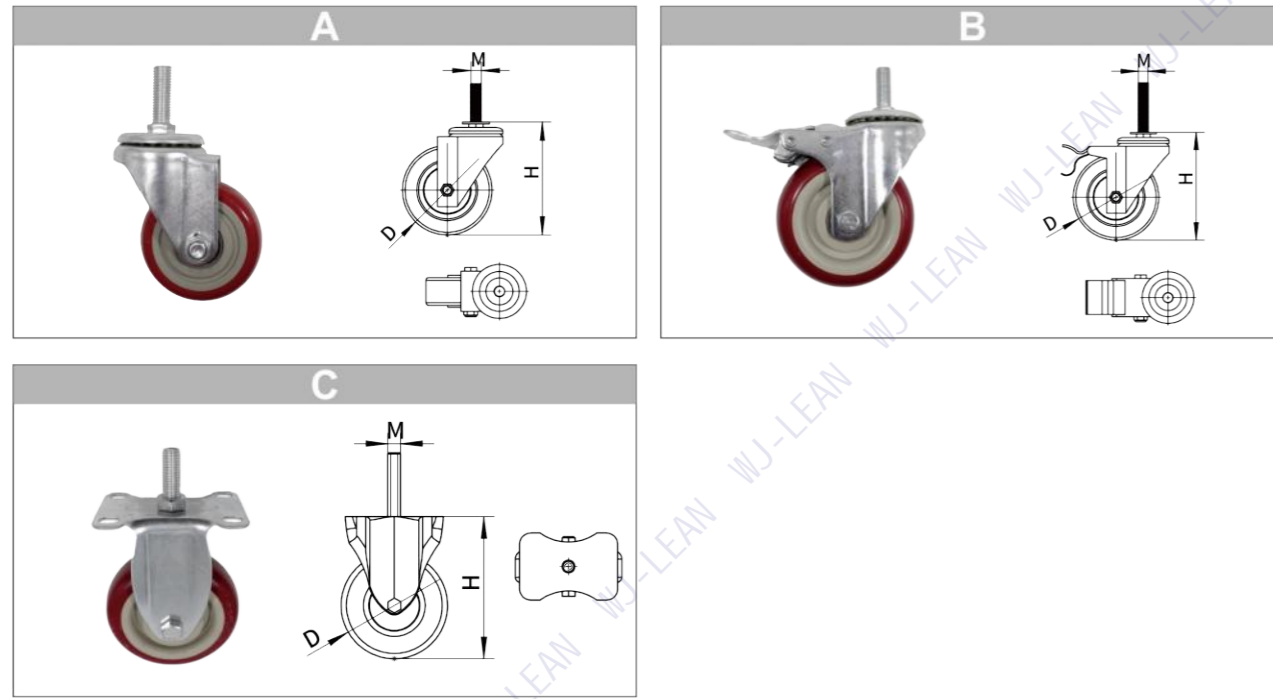

Insertion Caster Series	Wheel Dia (inch)	D 轮径 (mm)	T 丝杆外径	Material 轮子材质	Frame Material 支架材质	Offset Distance PIA 偏心距 (mm)	Loading 承重 (N)	H 高度 (mm)	Weight 单重 (g)	Package 每箱 (pcs)
WJ-203A	2"	50mm	M12*35	TPR/PU/Rubber	steel	22	300	67	280	100
WJ-203A-ESD	2"	50mm	M12*35	TPR/Rubber	steel	22	300	67	280	100
WJ-203B	2"	50mm	M12*35	TPR/PU/Rubber	steel	22	300	67	300	100
WJ-203B-ESD	2"	50mm	M12*35	TPR/Rubber	steel	22	300	67	300	100
WJ-203C	2"	50mm	M12*35	TPR/PU/Rubber	steel	/	300	67	280	100
WJ-203C-ESD	2"	50mm	M12*35	TPR/Rubber	steel	/	300	67	280	100
WJ-303A	3"	75mm	M12*35	TPR/PU/Rubber	steel	35	500	95	480	50
WJ-303A-ESD	3"	75mm	M12*35	TPR/Rubber	steel	35	500	95	480	50
WJ-303B	3"	75mm	M12*35	TPR/PU/Rubber	steel	35	500	95	580	50
WJ-303B-ESD	3"	75mm	M12*35	TPR/Rubber	steel	35	500	95	580	50
WJ-303C	3"	75mm	M12*35	TPR/PU/Rubber	steel	/	500	95	450	50
WJ-303C-ESD	3"	75mm	M12*35	TPR/Rubber	steel	/	500	95	450	50
WJ-403A	4"	100mm	M12*35	TPR/PU/Rubber	steel	32	600	132	630	40
WJ-403A-ESD	4"	100mm	M12*35	TPR/Rubber	steel	32	600	132	630	40
WJ-403B	4"	100mm	M12*35	TPR/PU/Rubber	steel	32	600	132	780	40
WJ-403B-ESD	4"	100mm	M12*35	TPR/Rubber	steel	32	600	132	780	40
WJ-403C	4"	100mm	M12*35	TPR/PU/Rubber	steel	/	600	132	620	40
WJ-403C-ESD	4"	100mm	M12*35	TPR/Rubber	steel	/	600	132	620	40

Adjust 脚杯

series	Code 型号	D/直径 (mm)	Hight/高度 L (mm)	Stem Diameter 丝杆外径 (t)	picture 图片
Normal-Type	AD3-3250-10	32	50	M10	
	AD3-3250-12	32	50	M12	
	AD3-32100-10	32	100	M10	
	AD3-32100-12	32	100	M12	
	AD4-5050-12	50	50	M12	
	AD4-50100-12	50	100	M12	
Rubber-Type ESD BLACK	AD5-3850-10	38	50	M10	
	AD5-3850-12	38	50	M12	
	AD5-50100-10	50	100	M10	
	AD5-50100-12	50	100	M12	
Rubber Pad-Type ESD BLACK	AD6-3260-10	32	60	M10	
	AD6-3560-10	35	60	M10	
	AD6-5460-12	54	60	M12	



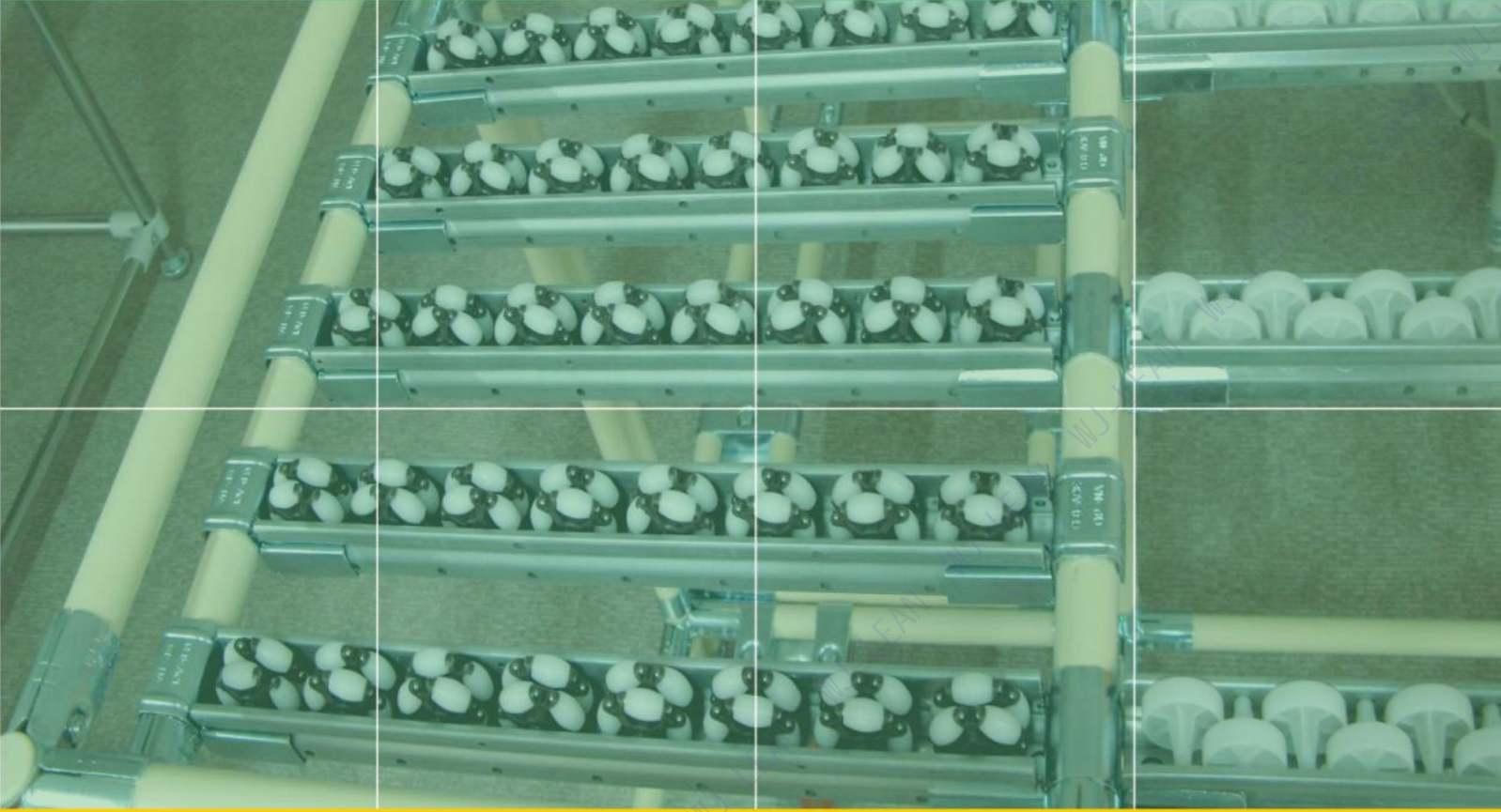

# 05 ALUMINUM ROLLER TRACKS

## 鋁滑軌

Roller Color颜色
WH White
BK Black
GR GRAY
EBK ESD Black
YE Yellow

Type & Dimension类型和尺寸		
Series系列	40 series	
Item No.产品名	RTA-40A	RTA-40D
High(mm) 总高	42.5	43
Slot High(mm) 槽高	35	32
Groove width(mm) 槽宽	40	40
Roller Diameter(mm) 轮径	33	30
Wheel width ( mm ) 轮宽	20	20
wheels distance(mm) 轮距	41	30
Roller Pitch(mm) 销钉直径"	4	4

### Aluminum Roller Tracks 铝滑轨

#### RTA-40A

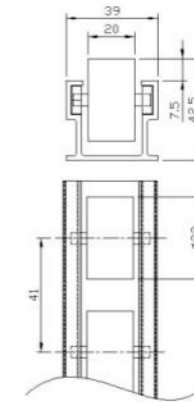
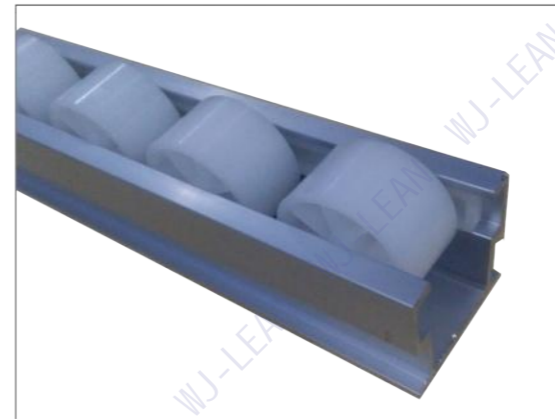

OD of wheel/轮径	33mm	Material/材质	Aluminum/铝
L.W/长度.宽度	4000mm.40mm	Color颜色	white/yellow/esd black 白色/黄色/防静电黑色
Weight/重量	0.5kg/m	Package/每箱	4pcs

#### RTA-40D

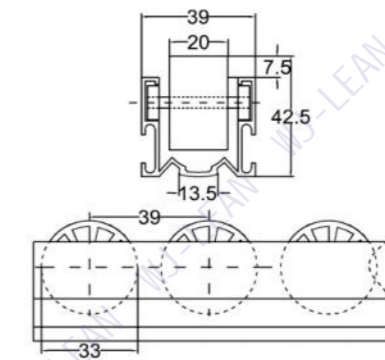

OD of wheel/轮径	30mm	Material/材质	Aluminum/铝
L.W/长度.宽度	4000mm.40mm	Color颜色	white/yellow/esd black 白色/黄色/防静电黑色
Weight/重量	0.8kg/m	Package/每箱	4pcs

### Roller track joint





# 06 ADJUST ACCESSORY TYPE

## 脚杯附件類

Roller Color颜色	material材质
<ul style="list-style-type: none"> <li>EB ESD BLACK 防静电黑</li> </ul>	plastic 塑胶
<ul style="list-style-type: none"> <li>GR GRAY灰色</li> </ul>	aluminum 铝材质
<ul style="list-style-type: none"> <li>BK Black黑色</li> </ul>	steel 铁材质
<ul style="list-style-type: none"> <li>SL Silve银白</li> </ul>	

### Adjust Accessory Type 脚杯附件类

**28AD-1A** ● ESD ● GRAY ● BK

M10/M12

**28AD-1B** ● ESD ● GRAY

M10/M12

**28AD-2** ● SL

**28AD-3** ● SL



Adjust Accessory Type 脚杯附件类

28AD-4

SL

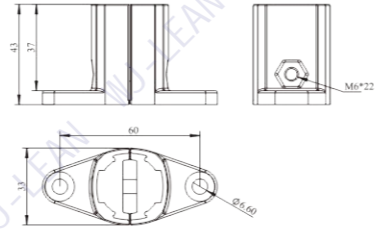

28AD-6

SL

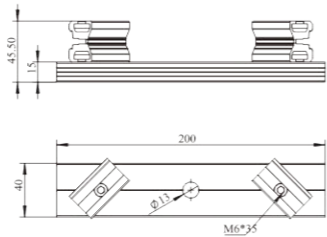
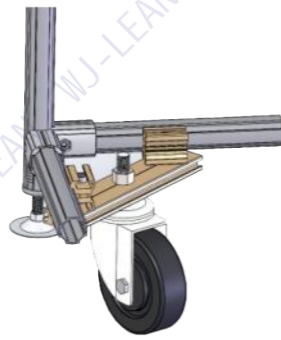

28AD-5A

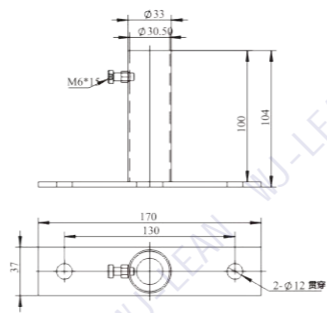
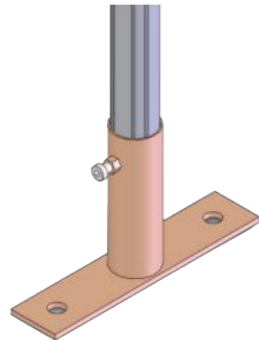
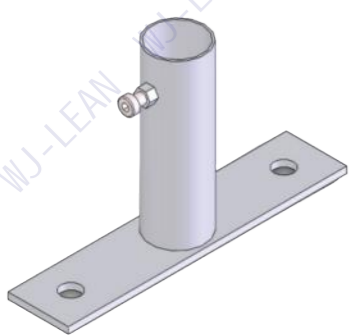

28AD-5B

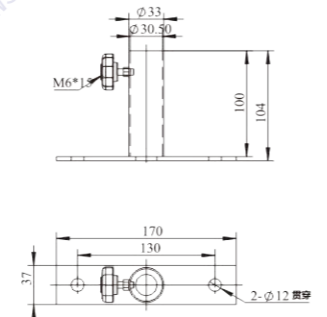
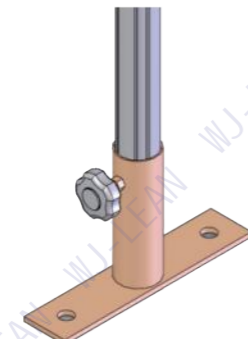
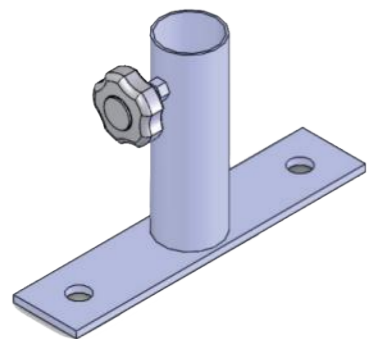

Adjust Accessory Type 脚杯附件类

28AD-5C

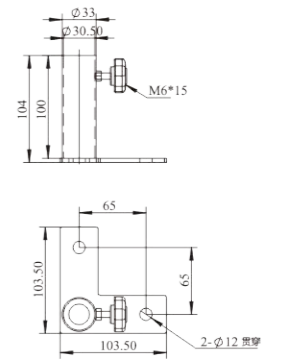
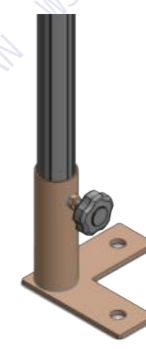
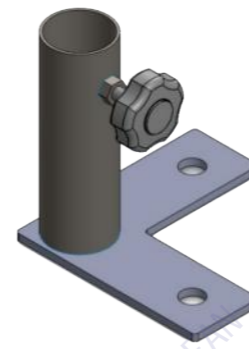

28AD-5D

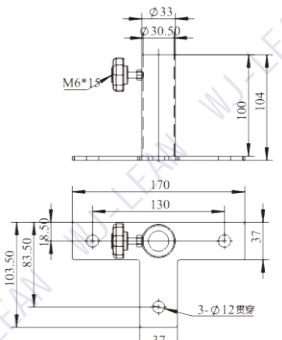
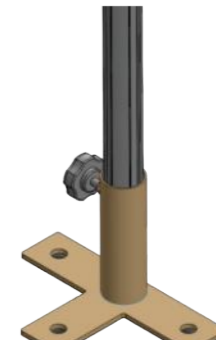
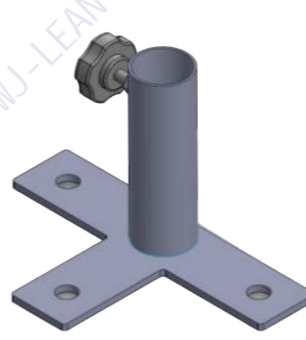

28AD-7

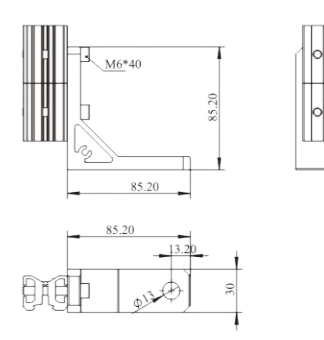
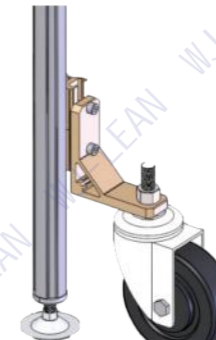
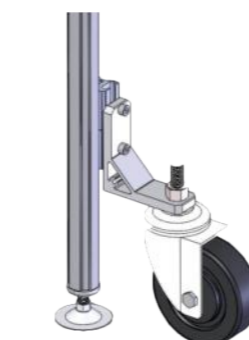

Adjust Accessory Type 脚杯附件类

28AD-8A



Item No 型号	specification 规格	Frame Material 支架材质	A*B 底板尺寸	H1高度 (mm)	H2 伸展后高度 (mm)	Loading 承重 (N)	weight 重量 (KG)
28AD-8A-3	3"	steel	62*91	96	120	80kg	1.4kg
28AD-8A-4	4"	steel	62*91	125	151	100kg	1.6kg
28AD-8A-5	5"	steel	62*91	154	180	120kg	1.8kg

28AD-8B



Item No 型号	specification 规格	Frame Material 支架材质	A*B 底板尺寸	H1高度 (mm)	H2 伸展后高度 (mm)	Loading 承重 (N)	weight 重量 (KG)
28AD-8B-5	5"	steel	120*120	154	180	150KG	1.8kg
28AD-8B-6	6"	steel	120*120	170	200	200KG	2.2kg

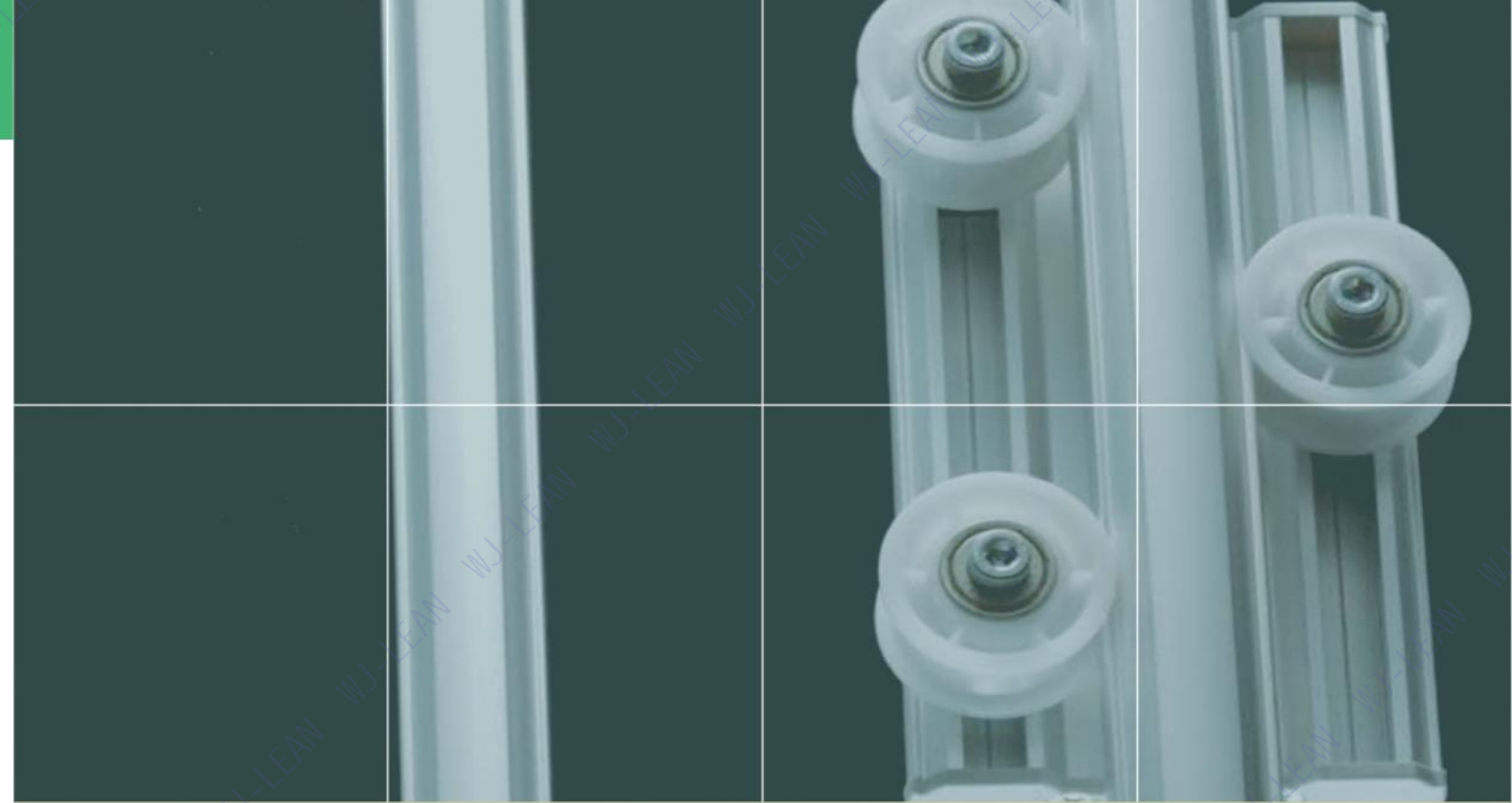

# 07 Movable accessories

## 可動類配件



Movable Accessories

可动类配件

28AT-1

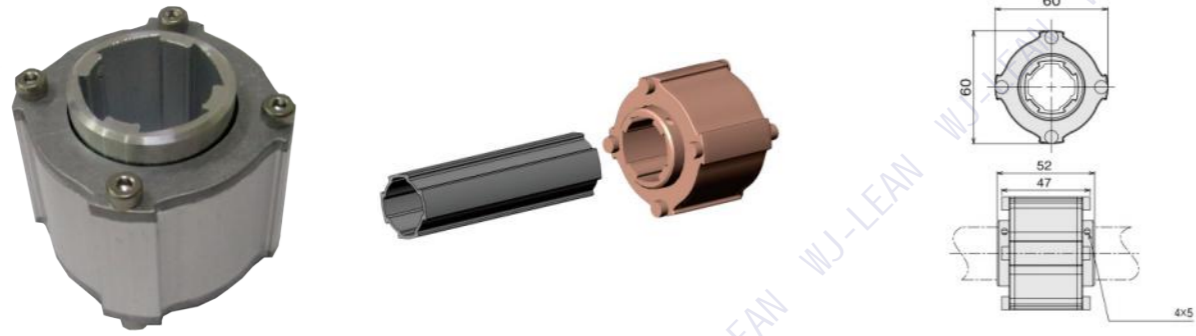

28AT-2A-37

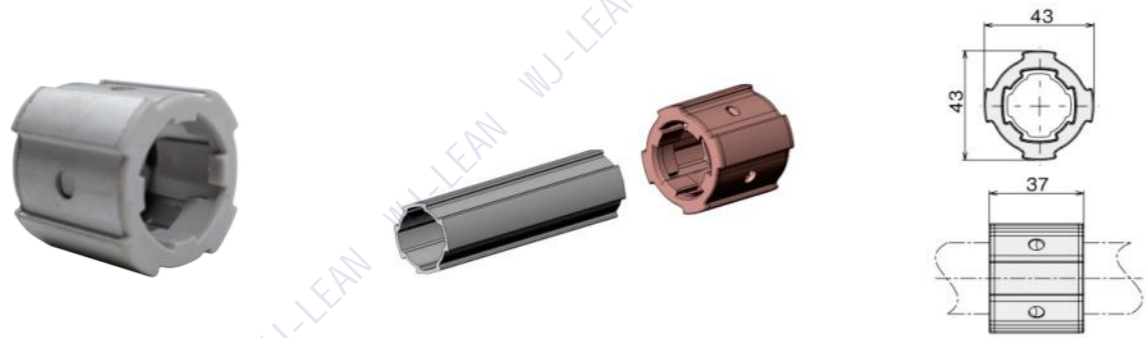

28AT-2A-55

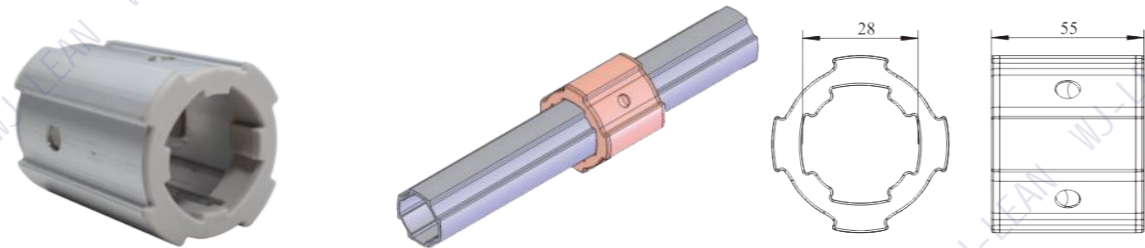

28AT-2A-100

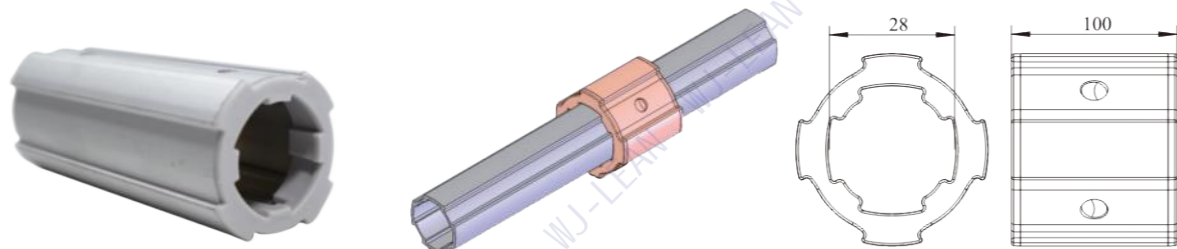

Movable Accessories

可动类配件

28AT-2A-150

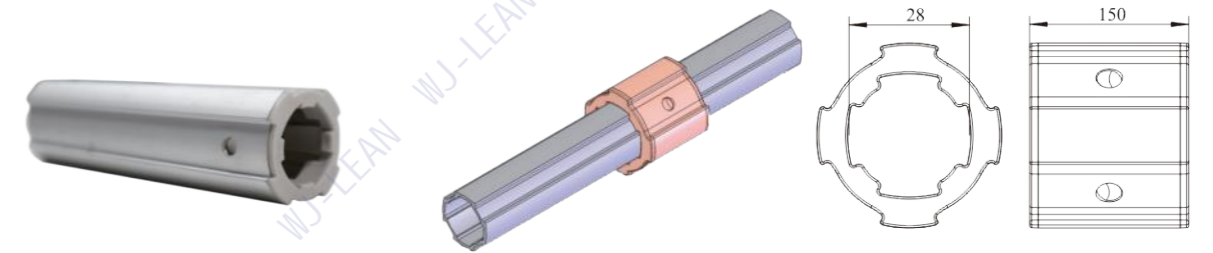

28AT-2B-37



28AT-2B-55

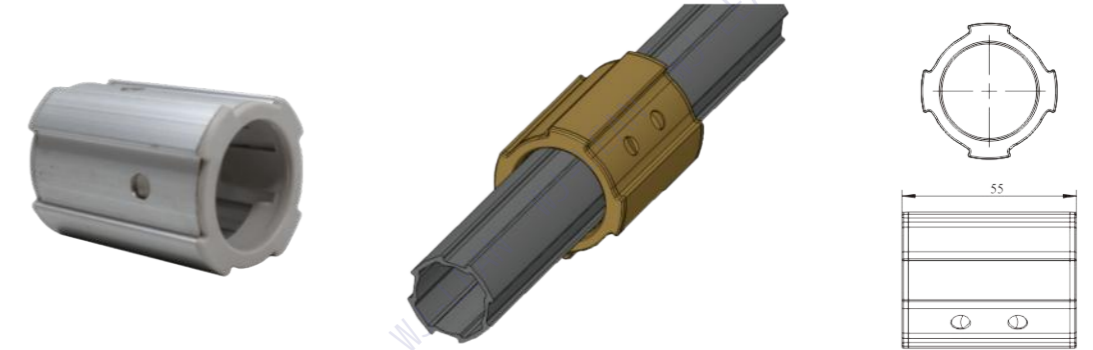

28AT-2B-100

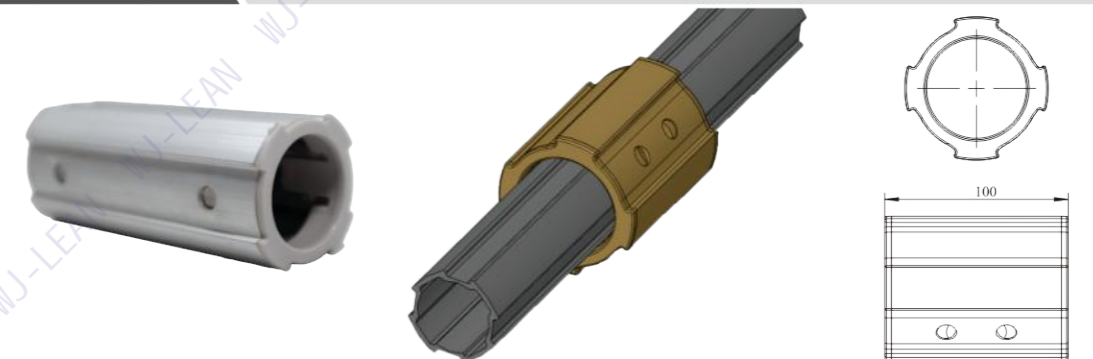





Movable Accessories

可动类配件

28AT-8

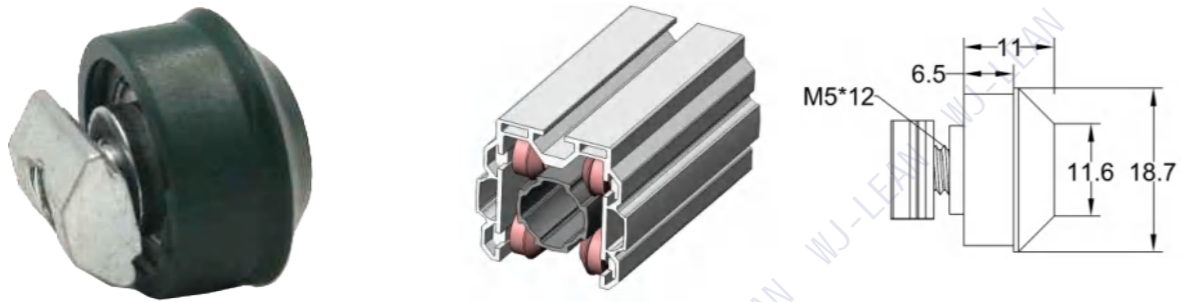

28AT-9

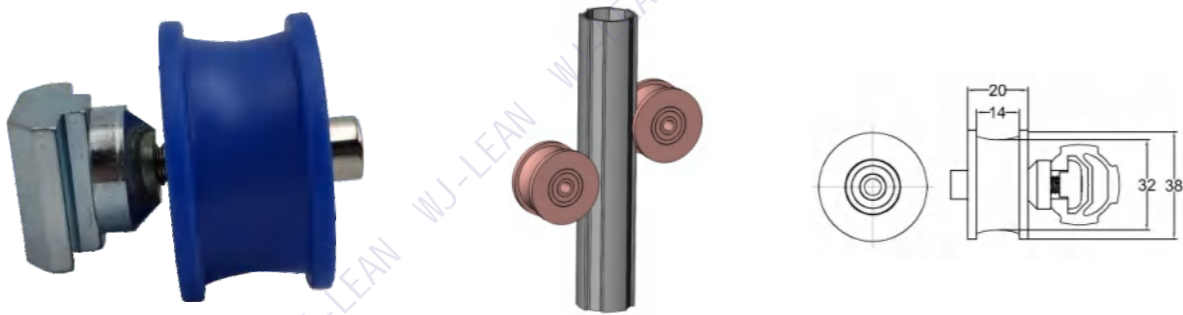

28AT-10



28AT-11

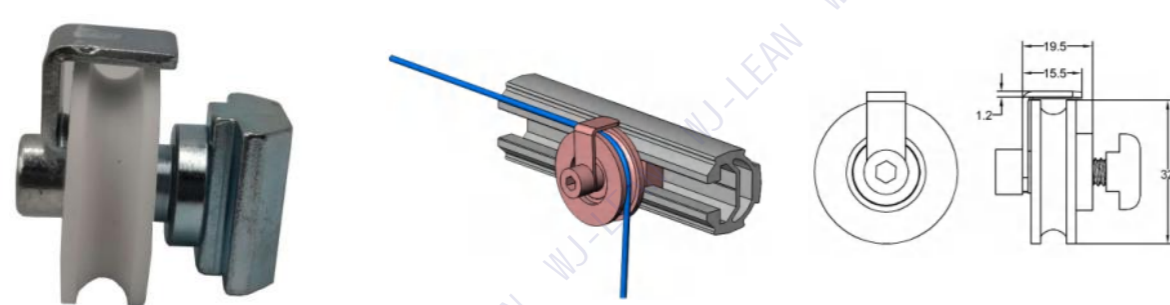

Movable Accessories

可动类配件

28AT-12A

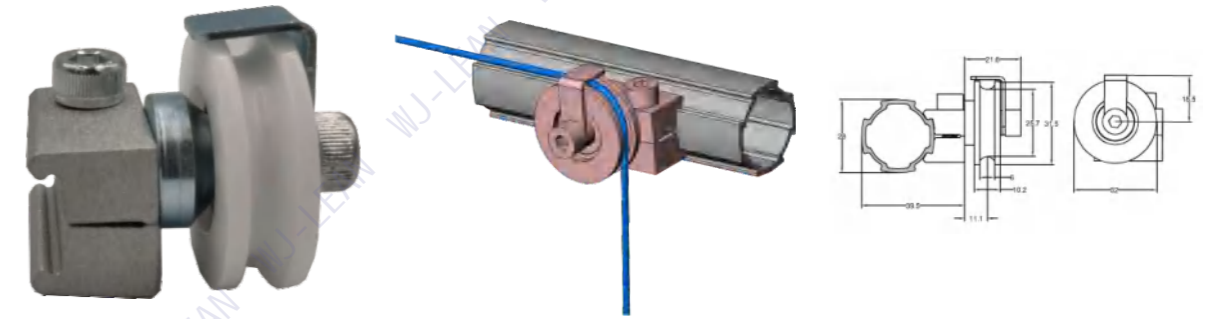

28AT-12B

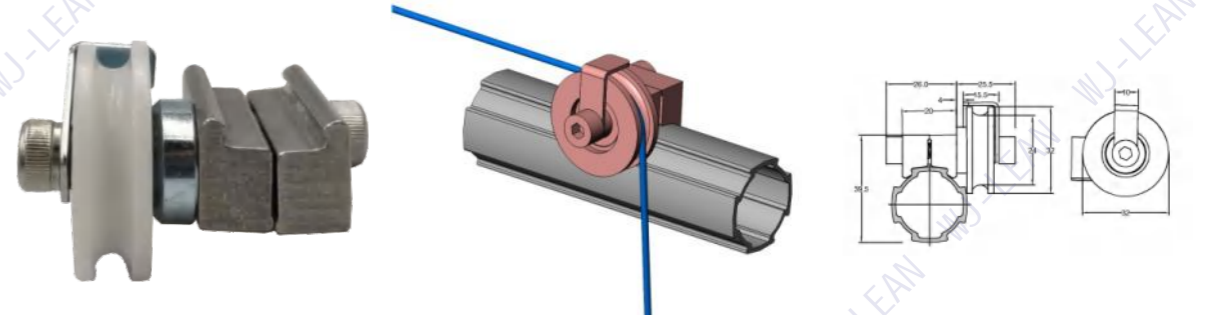

28AT-13

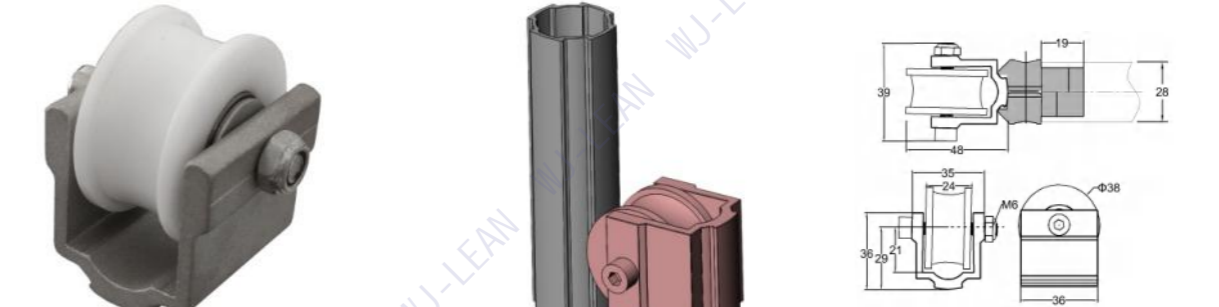

28AT-14

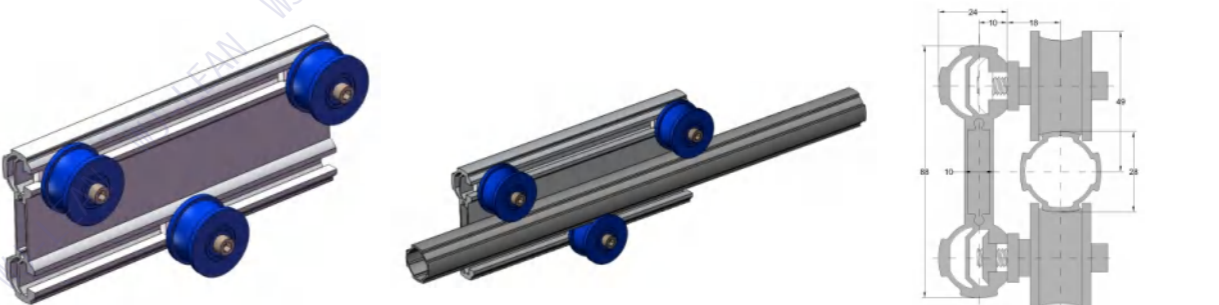

Movable Accessories

可动类配件

28AT-15A

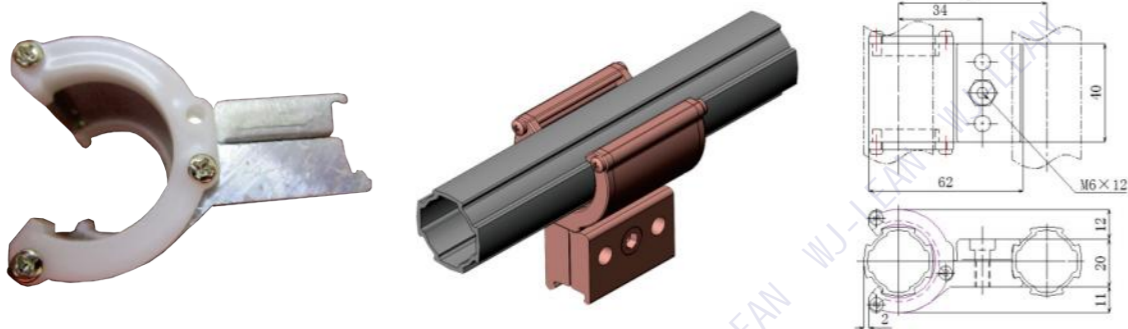

28AT-15B

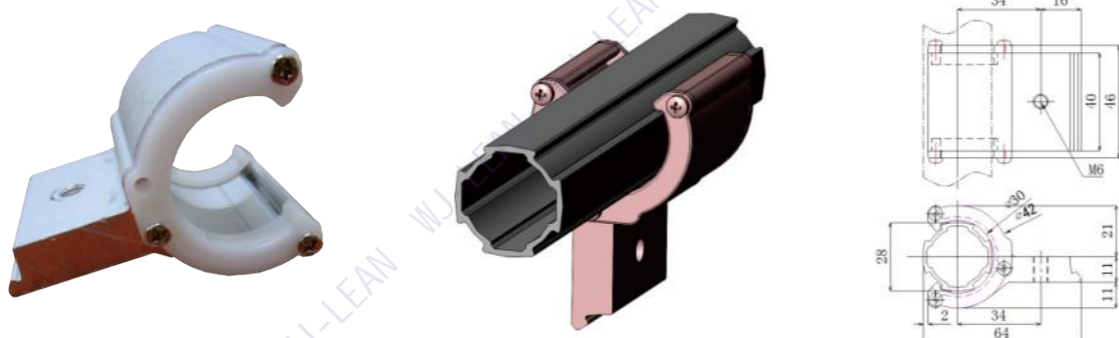

28AT-16

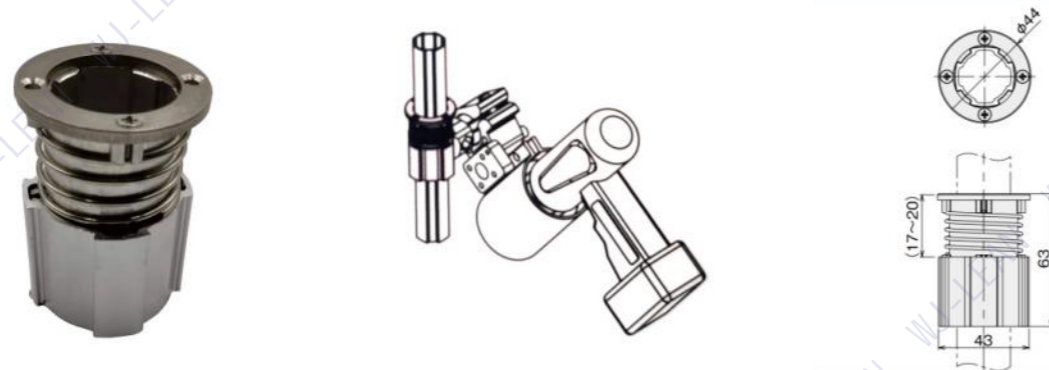

28AT-17



Movable Accessories

可动类配件

28AT-18

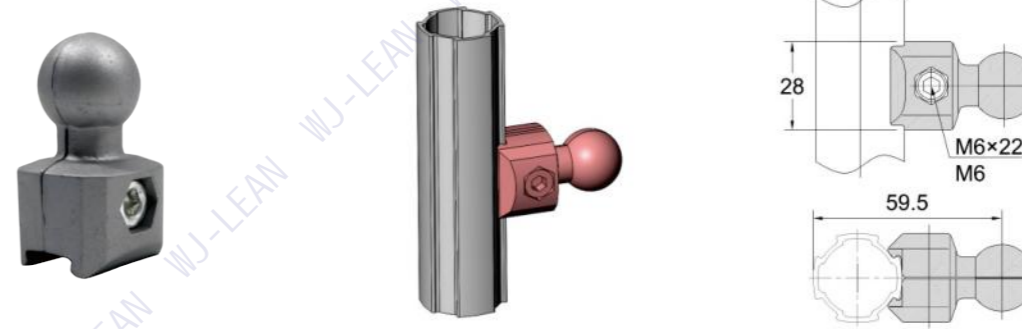

28AT-19

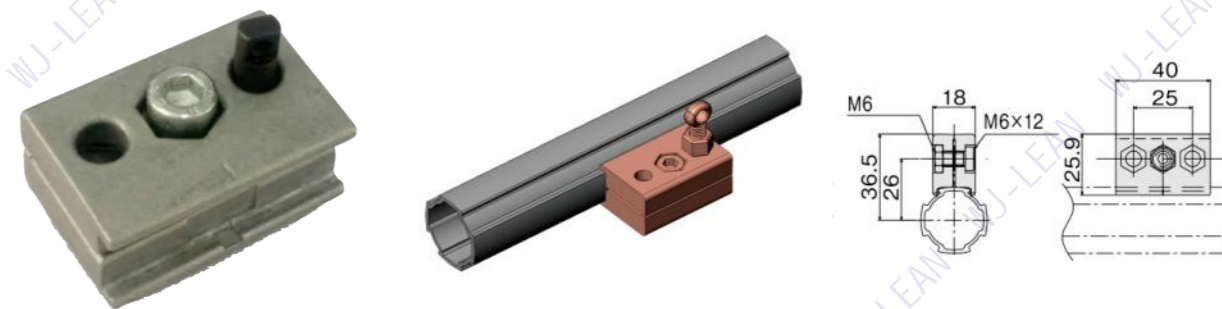

28AT-20A

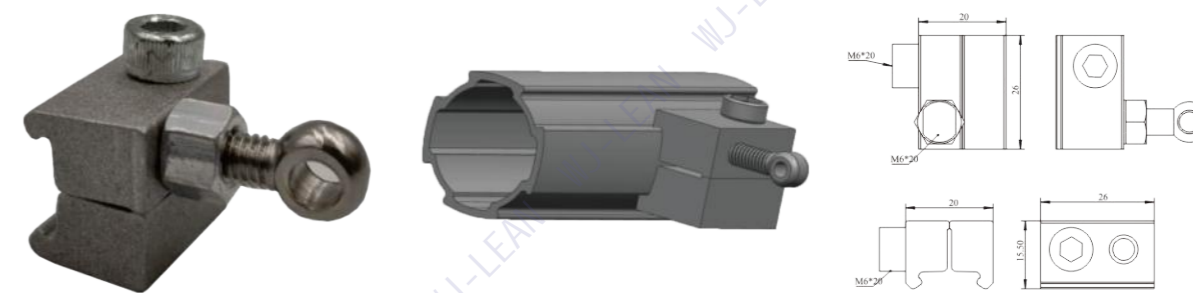

28AT-20B

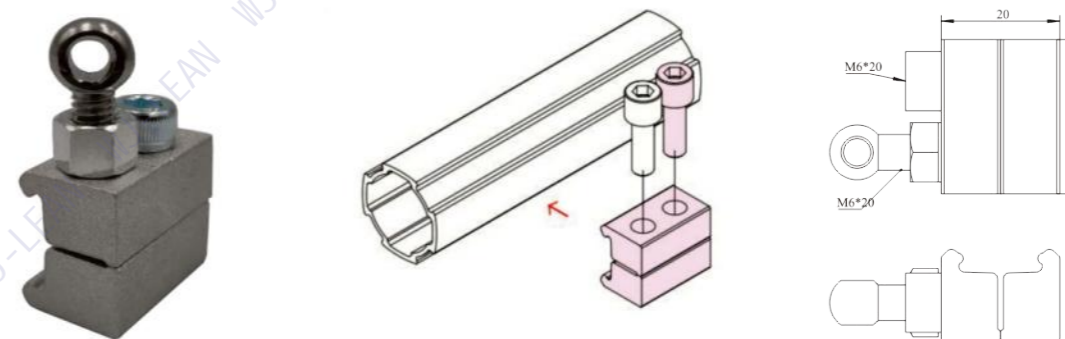



Movable Accessories

可动类配件

28AT-21

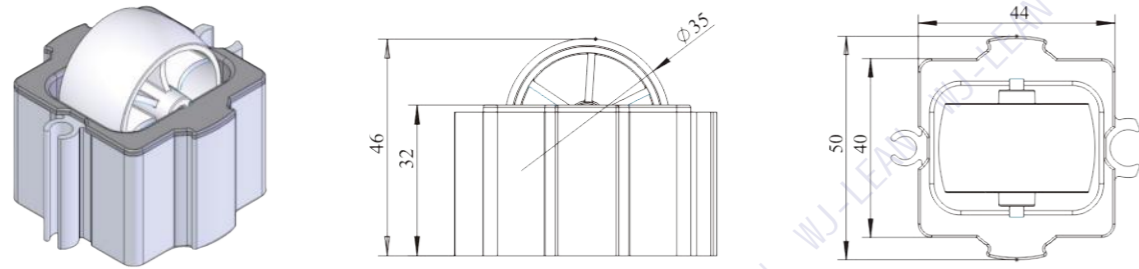

28AT-22

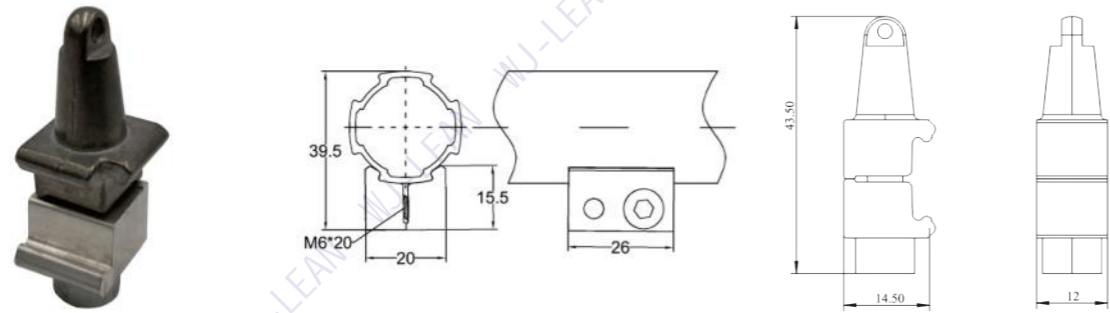

28AT-23A



28AT-23B

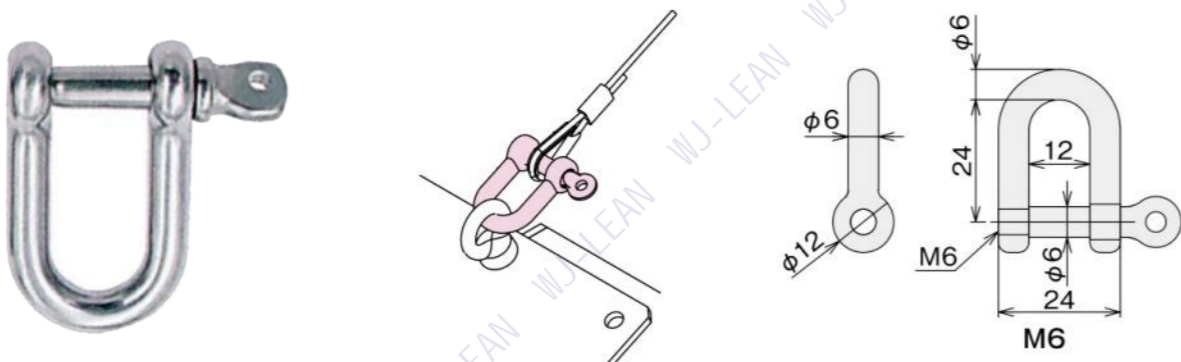

Movable Accessories

可动类配件

28AT-24

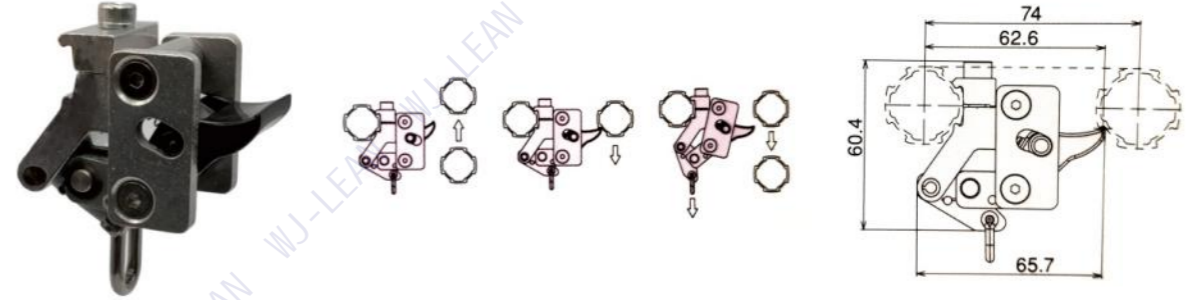

28AT-25A

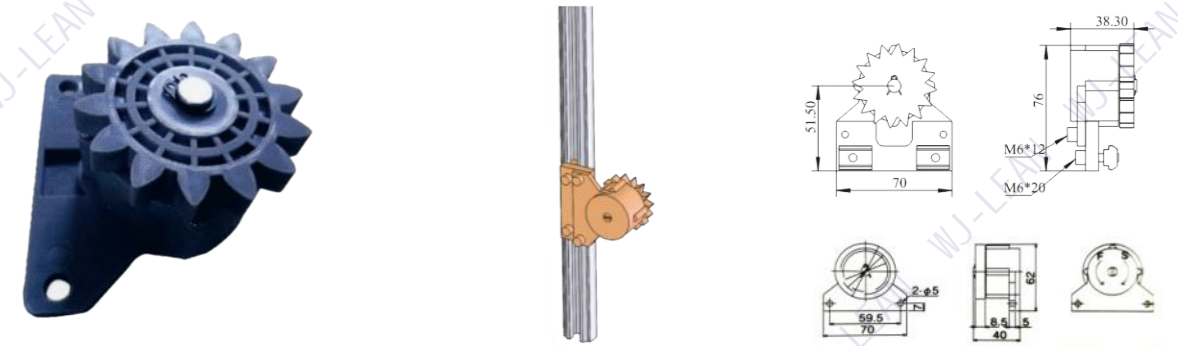

28AT-25B

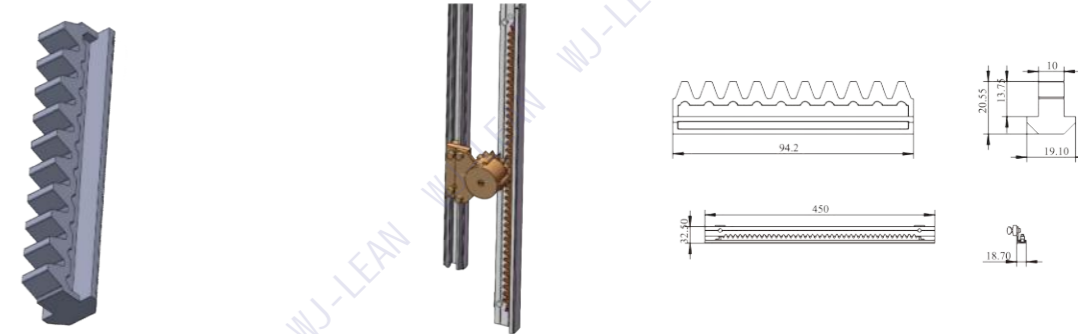

28AT-26A

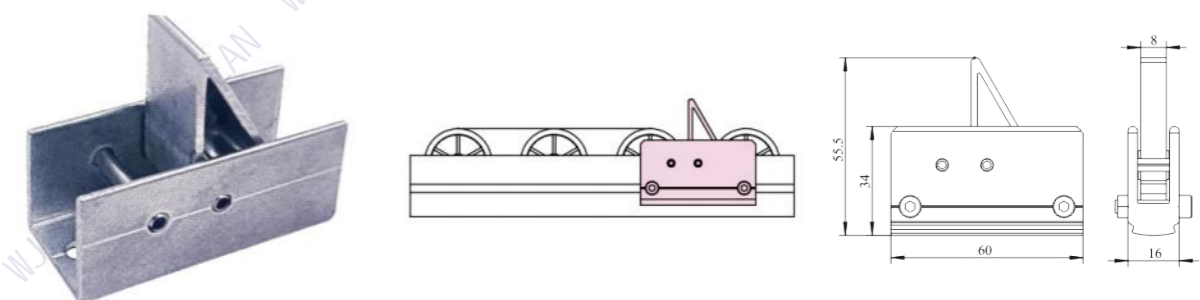

Movable Accessories 可动类配件

28AT-26B

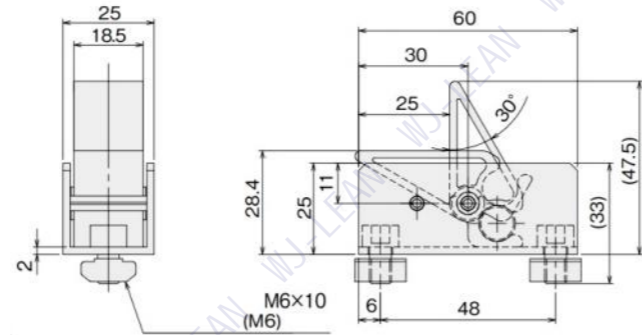
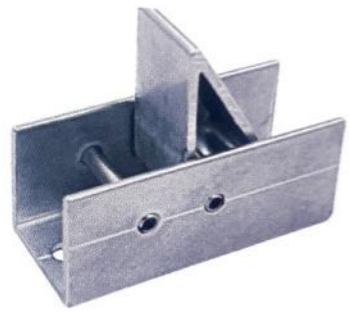

28AT-26C

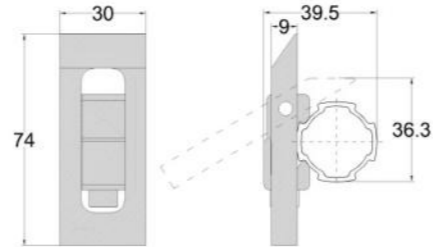
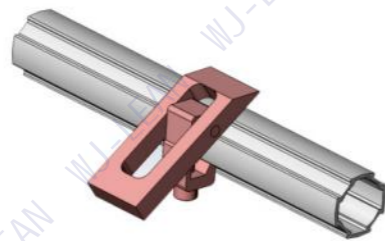

28AT-27

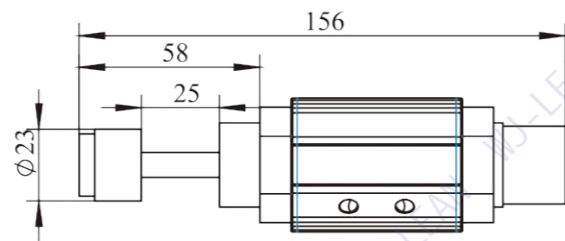
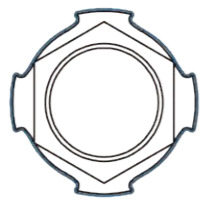

28AT-29

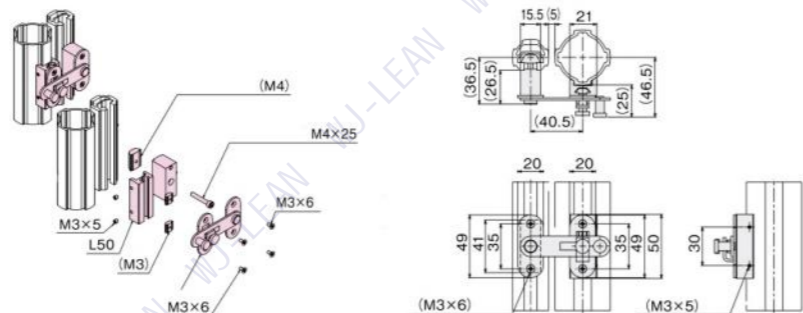
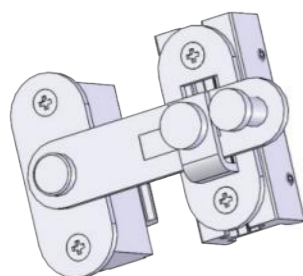

Movable Accessories 可动类配件

28AT-28

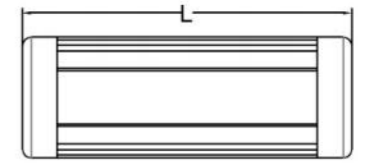
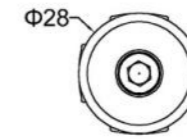
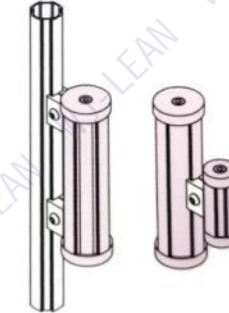
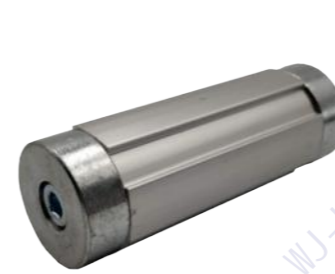

Gravity bar重力条

Item No型号	Material材质	Length (mm) 长度	Weight (kg) 重量
28AT-28A	aluminum+iron (铝+铁)	64	0.25kg
28AT-28B	aluminum+iron (铝+铁)	79	0.5kg
28AT-28C	aluminum+iron (铝+铁)	134	1kg
28AT-28D	aluminum+iron (铝+铁)	267	2kg

28AT-30

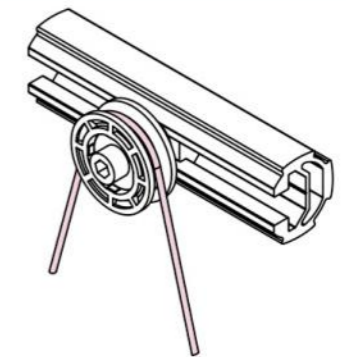

nylon rope尼龙绳

Item No型号	rope Dia (mm) 绳索线径	Length (mm) 长度	COLOR颜色
28AT-30-2	2mm	30m	blue
28AT-30-3	3mm	50m	blue
28AT-30-4	4mm	100m	blue



Movable Accessories

可动类配件

28AT-31



Gravity bar重力条

Item No型号	D	Wire Diameter 线径 (mm)	L1	L2	F.MAX最大 重荷(N)	Initial Tension 初张力(N)	Mass质量(g)
28AT-31A	10	0.8	51	73.9	10.88	1.47	6
28AT-31B	14	1	70	128.5	14.67	1.8	16
28AT-31C	16	1.2	106	192.2	21.85	2.88	32
28AT-31D	8	0.9	50	36.2	20.41	3.95	5
28AT-31E	12.5	1.2	75	75.3	28.96	4.93	17
28AT-31F	18	1.6	95	99.8	45.16	7.4	40
28AT-31G	8	1	54	30.3	28.08	6.2	6
28AT-31H	16	1.6	73	54	51.83	9.6	29
28AT-31I	16	1.8	100	64	73.9	15.8	62

28AT-32A

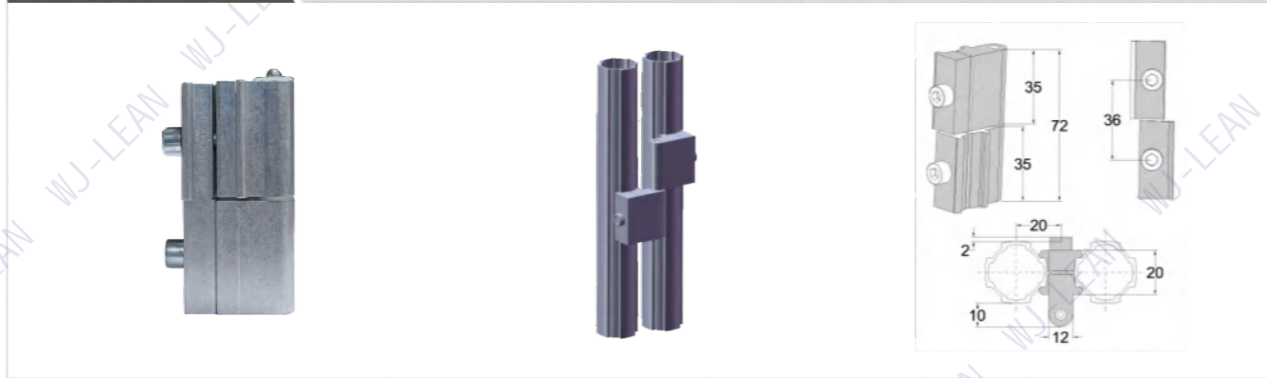

28AT-32B

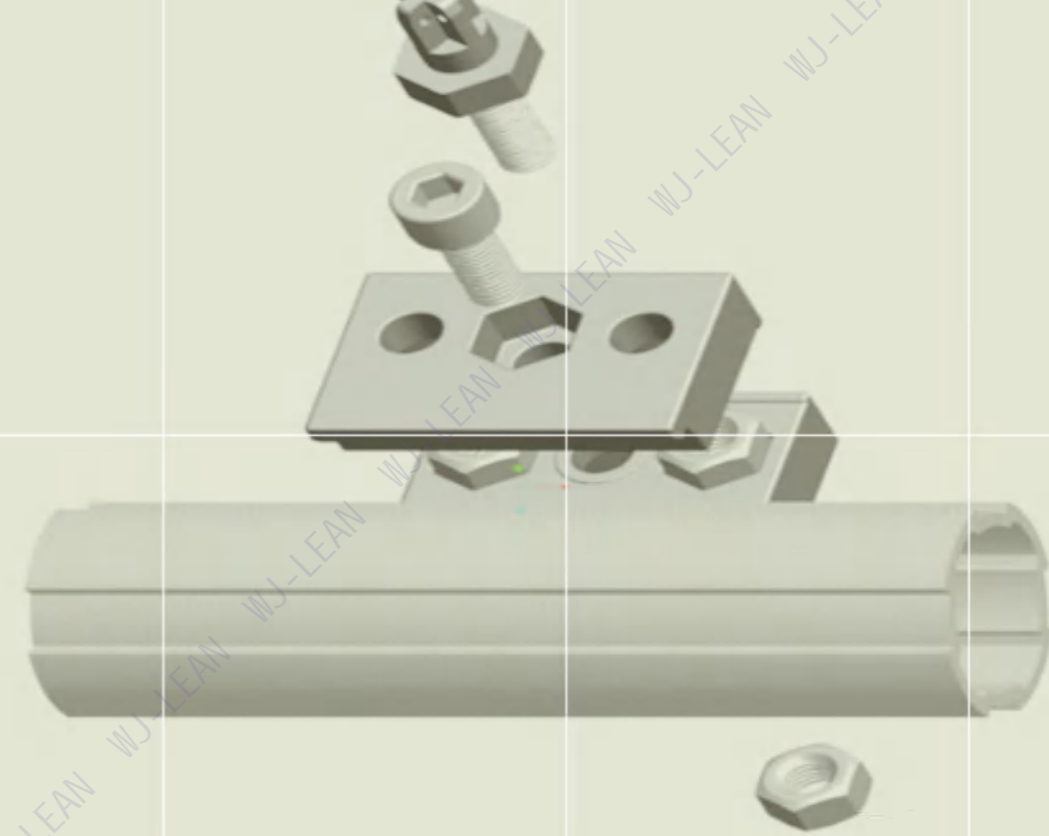

08 ACCESSORY FOR ALUMINUM TUBE

鋁管附件

Accessory For Aluminum Tube 铝管附件

Accessory For Aluminum Tube 铝管附件

**28AC-1**

**28AC-2**

**28AC-8**

**28AC-3**

**28AC-4**

**28AC-9**

**28AC-5**

**28AC-6A**

**28AC-10**

**28AC-11**

**28AC-6B**

**28AC-7**

**28AC-12**

**28AC-13(ABC)**

Item No型号	weight重量 (KG)	Length of wire rope 钢丝绳长度	rope Dia (mm) 绳索直径	min kg 负荷
28AC-13A	0.5-1.5kg	1.4M	2.5	40
28AC-13B	1.5-3kg	1.4M	2.5	50
28AC-13C	3-6kg	1.4M	2.5	60



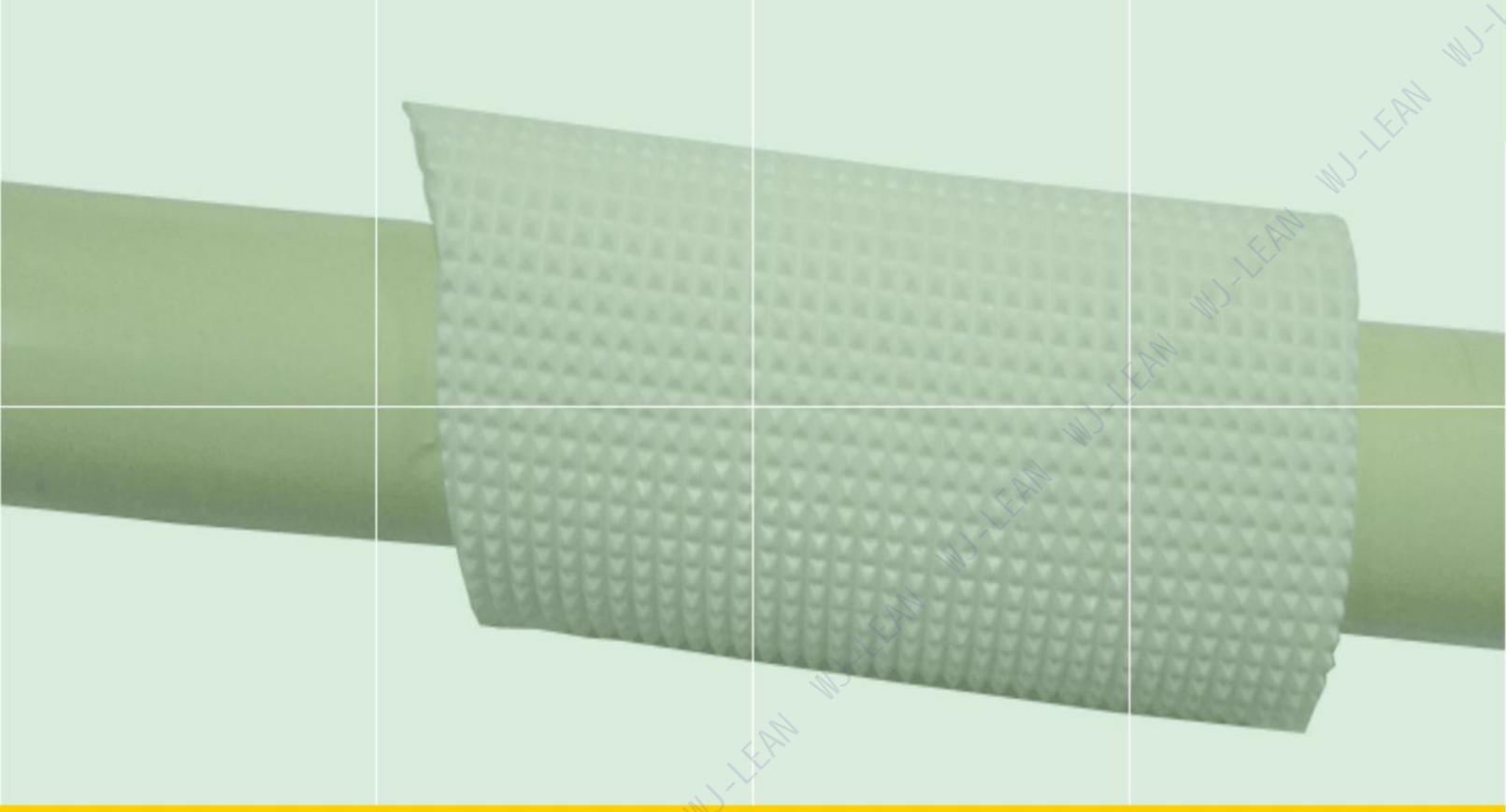

# 09 PLASTIC GUIDE

## 塑膠條

Material材质	length长度	COLOR颜色
plastic 塑料	2M 2米 3M 2米	<ul style="list-style-type: none"> <li><span style="display: inline-block; width: 10px; height: 10px; background-color: gray; border-radius: 50%; margin-right: 5px;"></span> GR GRAY灰色</li> <li><span style="display: inline-block; width: 10px; height: 10px; background-color: white; border: 1px solid black; border-radius: 50%; margin-right: 5px;"></span> WH White白色</li> <li><span style="display: inline-block; width: 10px; height: 10px; background-color: black; border-radius: 50%; margin-right: 5px;"></span> BK Black黑色</li> <li><span style="display: inline-block; width: 10px; height: 10px; background-color: yellow; border-radius: 50%; margin-right: 5px;"></span> YE Yellow黄色</li> </ul>

Plastic Guide 塑胶条

**28PG-1**

**28PG-2**

**28PG-3**

**28PG-4**

**28PG-5A-3MM**

**28PG-5A-5MM**

Plastic Guide 塑胶条

TYPE类型	PART No型号	ITEM名称	SPEC规格	COLOR颜色
	1N330	round screw	M3*30	white
	1N420	round screw	M4*20	white
	1N610	round screw	M6*10	white
	1N612	round screw	M6*12	white
	1N618	round screw	M6*18	white
	1N620	round screw	M6*20	white
	1N622	round screw	M6*22	white
	1N625	round screw	M6*25	white
	1N630	round screw	M6*30	white
	1N635	round screw	M6*35	white
	1N640	round screw	M6*40	white
	1N835	round screw	M8*35	white
	2N405	include screw	M4*5	white
	2N408	include screw	M4*8	white
	2N8	include screw	M8*12	white
	3N5	Flat screw	M5*15	white
	3N610	Flat screw	M6*10	white
	3N614	Flat screw	M6*14	white
	3N622	Flat screw	M6*22	white
	4N3	Half round screw	M3*12	white
	4N4	Half round screw	M4*14	white
	5N6	handle screw	M6*15	white
	5N6	handle screw	M6*35	white
	6N6	Perforated screw	M6*30	white

Plastic Guide 塑胶条



TYPE类型	PART No型号	ITEM名称	SPEC规格	COLOR颜色
	1M5	NUT	M5	white
	1M6	NUT	M6	white
	1M8	NUT	M8	white
	1M12	NUT	M12	white
	2M4	slide nut	M4	white
	2M5	slide nut	M5	white
	2M6	slide nut	M6	white
	3M4	Marble nut	M4	white
	3M5	Marble nut	M5	white
	3M6	Marble nut	M6	white
	4M4	FLAT WASHER	M4	white
	4M6	FLAT WASHER	M6	white





# 10 19 SERIES

## 19系列

Series系列	Roller Color颜色	Material材质	Length长度
 19mm series	 SL silve 银白	6063T5	Extrusion 挤出  Die-casting 压铸

### 19 Series 19系列

**AP-19A** ● SL



Material 6063T5  
Weight 0.173 kg/m  
Length 4/6 Meters

**AP-19B** ● SL



Material 6063T5  
Weight 0.16 kg/m  
Length 4/6 Meters

**AP-19C** ● SL

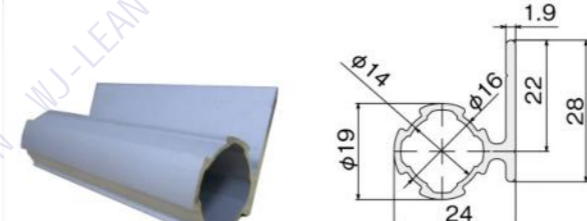

Material 6063T5  
Weight 0.15 kg/m  
Length 4/6 Meters

**AP-19D** ● SL



Material 6063T5  
Weight 0.15kg/m  
Length 4/6 Meters

**AP-19G** ● SL



Material 6063T5  
Weight 0.56 kg/m  
Length 4/6 Meters

19 Series 19系列

19J-1

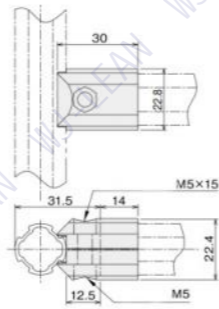
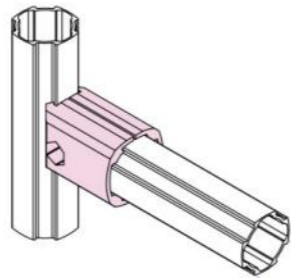

Weight 0.02 kg Package 300 pcs

19J-1B

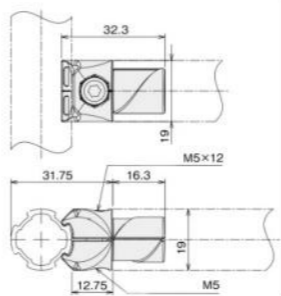
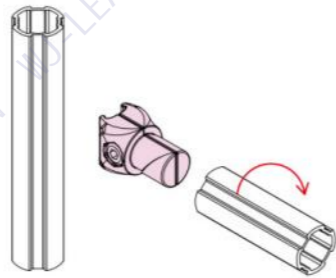

Weight 0.023 kg Package 300 pcs

19J-1B-28

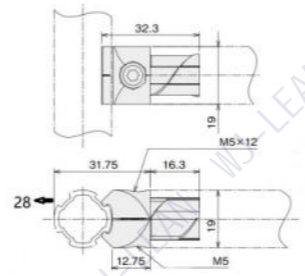
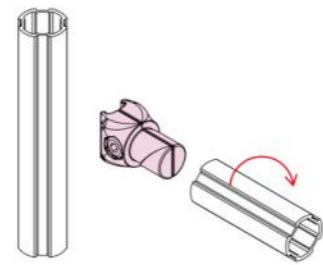

Weight 0.032 kg Package 300 pcs

19J-2A

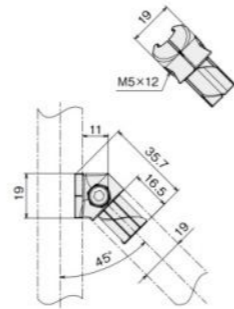
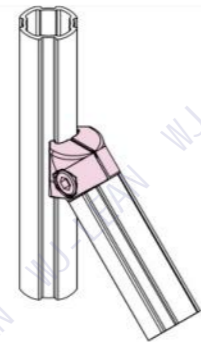

Weight 0.024 kg Package 300 pcs

19 Series 19系列

19J-3

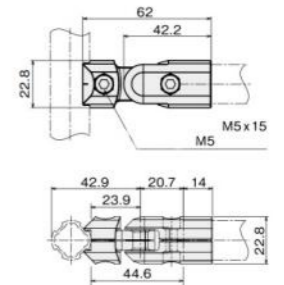
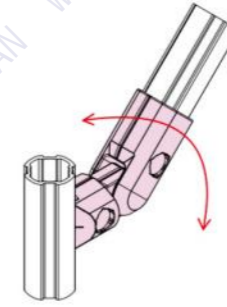

Weight 0.048 kg Package 200 pcs

19J-4

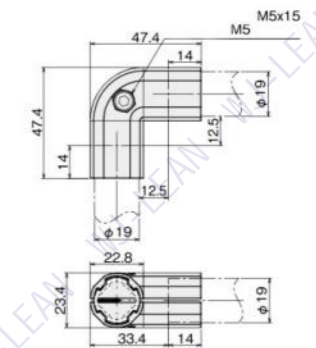
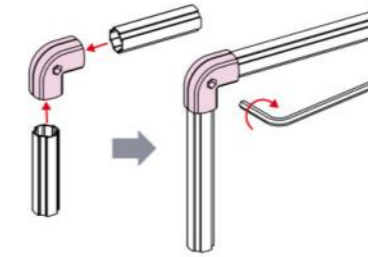

Weight 0.04 kg Package 200 pcs

19J-5

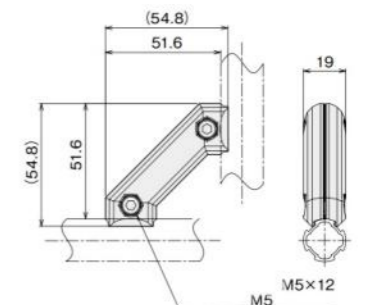
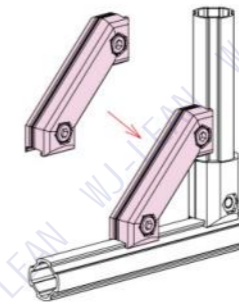

Weight 0.04 kg Package 200 pcs

19J-8

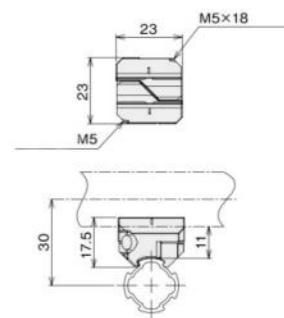
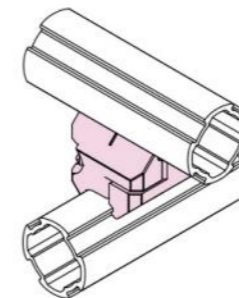

Weight 0.012 kg Package 300 pcs



19 Series 19系列

19J-9



Weight 0.027 kg Package 300 pcs

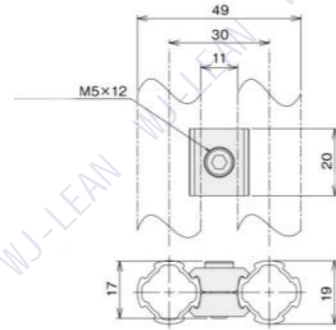
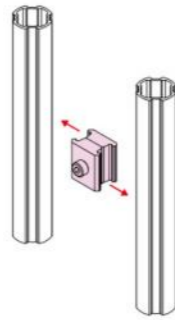

19J-9-28



Weight 0.018 kg Package 300 pcs

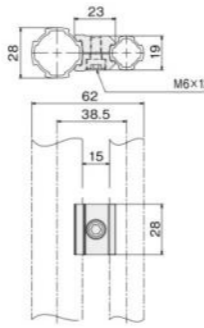
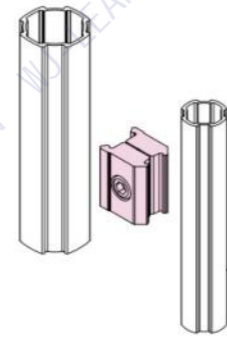

19CAP-1

EB GR BK



Weight 0.003 kg Package 2000 pcs

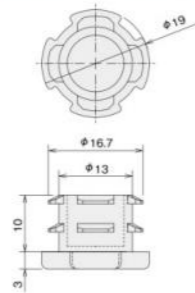

19CAP-2

EB GR BK



Weight 0.001 kg Package 3000 pcs

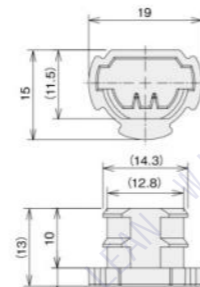

11 43 SERIES

43系列

Series系列	Roller Color颜色	Material材质	Length长度
 43mm series	 SL silve 银白	6063T5	Extrusion 挤出  Die-casting 压铸

43 Series 43系列

**AP-43A** ● SL



Material 6063T5  
Weight 0.76 kg/m  
Length 4/6 Meters

**AP-43B** ● SL



Material 6063T5  
Weight 1 kg/m  
Length 4/6 Meters

**AP-43G** ● SL





Material 6063T5  
Weight 1.56 kg/m  
Length 4/6 Meters

**43cap1** ● EB ● GR ● BK

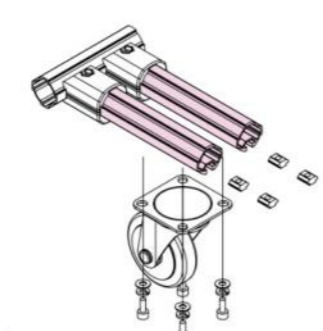
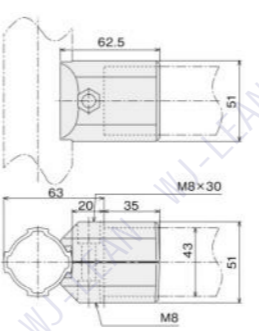

Weight 0.009 kg  
Package 500 pcs

**43J-1**

Weight 0.12 kg  
Package 80 pcs

**43J-1B**





Weight 0.123 kg  
Package 100 pcs

43 Series 43系列

**43J-2**





Weight 0.14 kg  
Package 100 pcs

**43J-3**

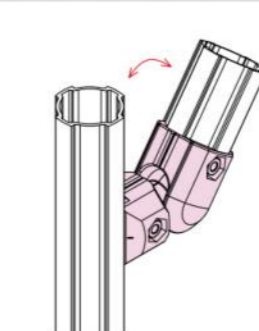
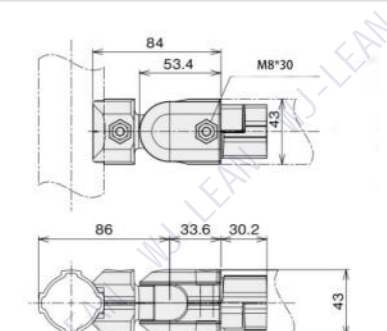
Weight 0.18 kg  
Package 50 pcs

**43J-4**

Weight 0.23 kg  
Package 200 pcs

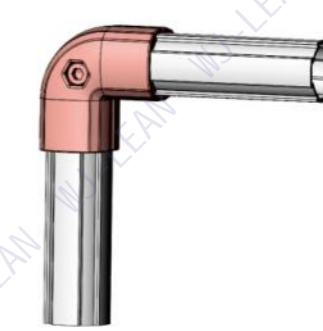
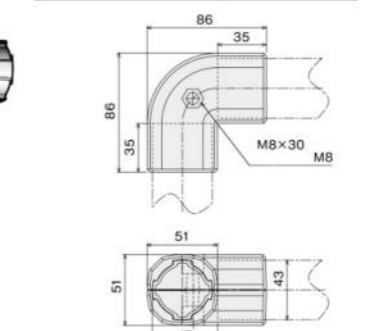
**43J-5**



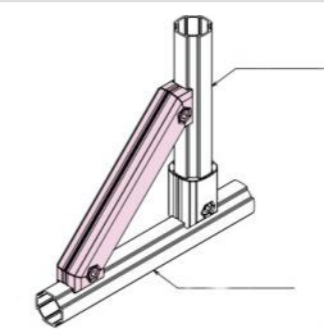
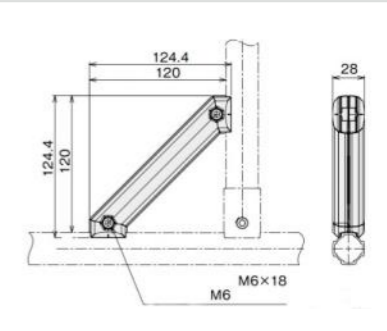

Weight 0.21 kg  
Package 50 pcs

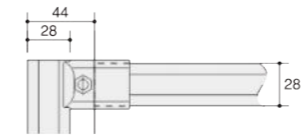

28 series technical data

28J-1



$$l = A - (44 \times 2)$$

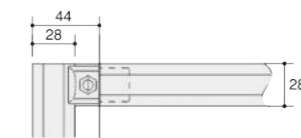

$$l = A - (44 \times 2)$$

28J-1A

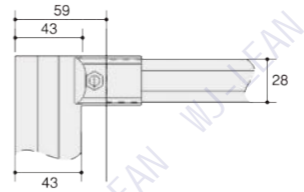

$$l = A - (59 \times 2)$$

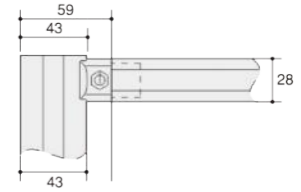

$$l = A - (59 \times 2)$$

28J-1B

28J-2

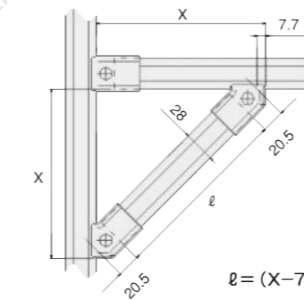

$$l = (X - 7.7) \times \sqrt{2} - 41$$

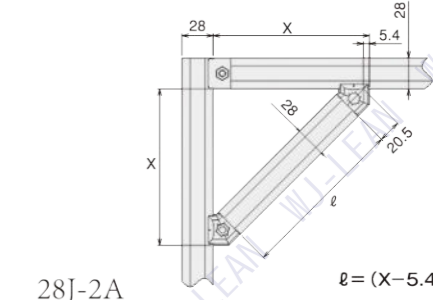

28J-2A

$$l = (X - 5.4) \times \sqrt{2} - 41$$

28J-3

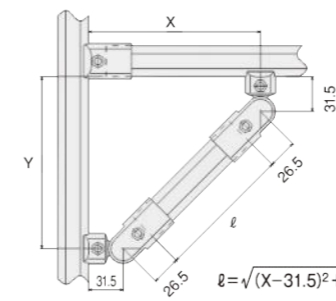

$$l = \sqrt{(X - 31.5)^2 + (Y - 31.5)^2} - 26.5 \times 2$$

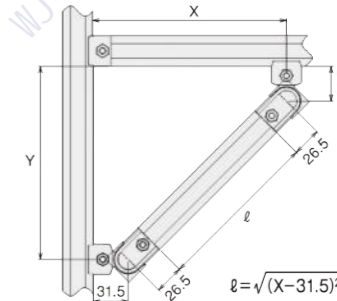

28J-3A

$$l = \sqrt{(X - 31.5)^2 + (Y - 31.5)^2} - 26.5 \times 2$$

12 TECHNICAL DATA

技術數據

28 series technical data

28J-3

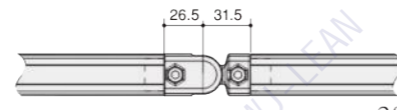
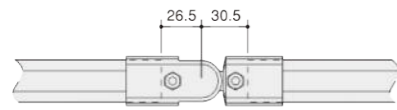

28J-3C

28J-4

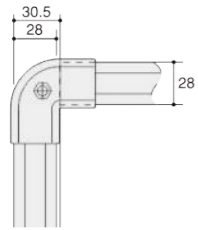

ℓ = A - (30.5 × 2)

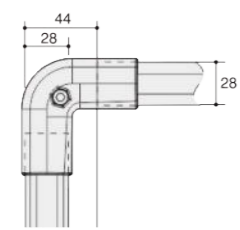

ℓ = A - (44 × 2)

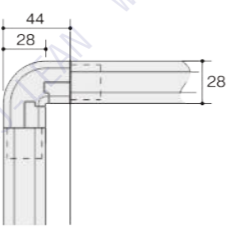

ℓ = A - (44 × 2)

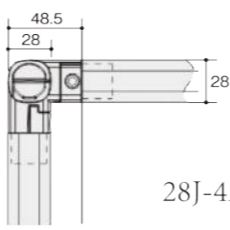

ℓ = A - (48.5 × 2)

28J-4A

28AC-1

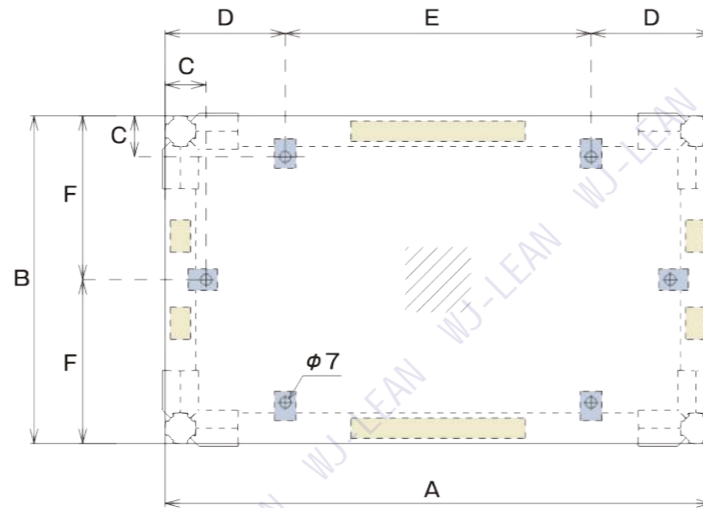
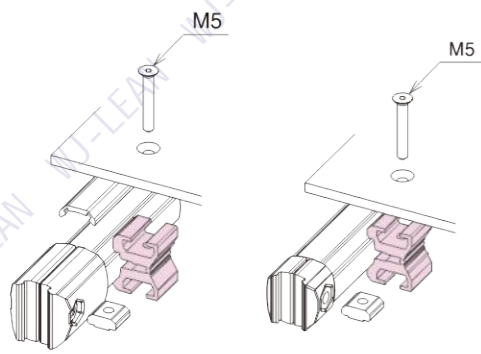

		C	D	E	F
28mm	A × B	37.5	80mm	500mm	80mm - 200mm
19mm	A × B	27	60mm	500mm	60mm - 200mm
43mm	A × B	53	120mm	500mm	120mm - 200mm

28 series technical data

28PG-5

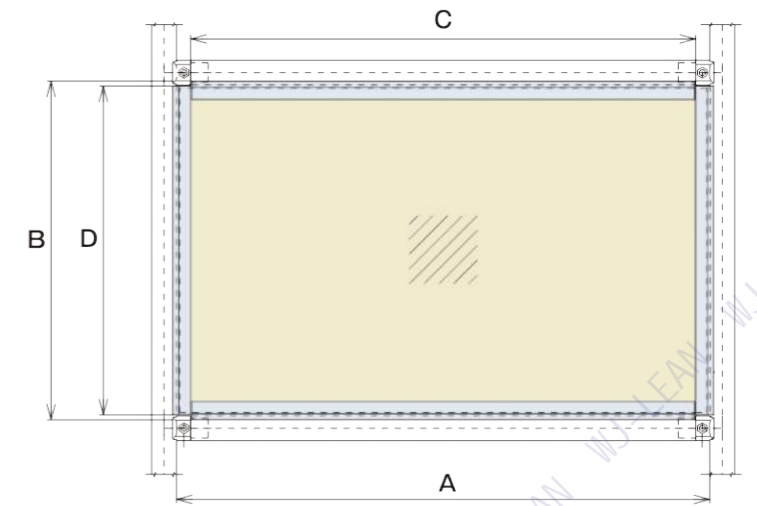
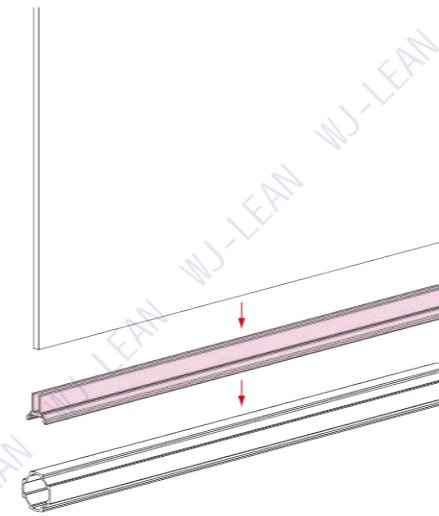

Item No	Plank size	Plank size	
		C	D
28PG-5A-3MM	(A-7) × (B-7)	A-80	B-7
	(A-7) × (B-7)	A-34	B-2
28PG-5B-5MM	(A-6) × (B-6)	A-55	B-6
	(A-6) × (B-6)	A-27.4	B-2



28 series technical data

28J-1B

滑动负载 (N) Slide the load	800	拉伸负载 (N) Tensile load	420	力矩负载 Torque load		长度 Length (mm)	容许负载 Allow the load(N)	
				垂直 vertical	水平 horizontal		纵 lengthways	横 crosswise
						100	90	60
						200	45	30
						300	30	20
						500	18	12
						容许力矩 Allowable moment (N·m)	9	6

28J-2A

滑动负载 (N) Slide the load	600	拉伸负载 (N) Tensile load	275	力矩负载 Torque load	长度 Length (mm)	容许负载 Allow the load(N)	
						纵 lengthways	横 crosswise
					100	116	
					200	58	
					300	39	
					500	23	
					容许力矩 Allowable moment (N·m)	11.6	

28J-2

滑动负载 (N) Slide the load	700	拉伸负载 (N) Tensile load	260	力矩负载 Torque load	长度 Length (mm)	容许负载 Allow the load(N)	
						纵 lengthways	横 crosswise
					100	165	
					200	83	
					300	55	
					500	33	
					容许力矩 Allowable moment (N·m)	16.5	

28J-3

负载 load(N)	700	负载 load(N)	390

28J-3A

负载 load(N)	800	负载 load(N)	170

28J-3C

负载 load(N)	170

28J-3B

负载 load(N)	390

28 series technical data

28J-4

负载 load(N)	170	力矩负载 Torque load		长度 Length (mm)	容许负载 Allow the load(N)	
		垂直 vertical	水平 horizontal		纵 lengthways	横 crosswise
				100	200	150
				200	100	75
				300	67	50
				500	40	30
				容许力矩 Allowable moment (N·m)	20	15

28J-4A

滑动负载 (N) Slide the load	280	力矩负载 Torque load		长度 Length (mm)	容许负载 Allow the load(N)	
		垂直 vertical	水平 horizontal		纵 lengthways	横 crosswise
				100	130	65
				200	65	33
				300	43	22
				500	26	13
				容许力矩 Allowable moment (N·m)	13	6.5

28J-5

滑动负载 (N) Slide the load	1400	力矩负载 Torque load	长度 Length (mm)	容许负载 Allow the load(N)	
				多连接器外部型 Multi connector external model	多连接器内装型 Multi connector internal model
			100	400	400
			200	200	200
			300	133	133
			500	80	80
			容许力矩 Allowable moment (N·m)	40	40

28J-5A

滑动负载 (N) Slide the load	1150	力矩负载 Torque load	长度 Length (mm)	容许负载 Allow the load(N)	
				多连接器外部型 Multi connector external model	多连接器内装型 Multi connector internal model
			100	950	950
			200	475	475
			300	317	317
			500	190	190
			容许力矩 Allowable moment (N·m)	95	95

28J-6

滑动负载 (N) Slide the load	1000	拉伸负载 (N) Tensile load	450	力矩负载 Torque load		长度 Length (mm)	容许负载 Allow the load(N)	
				垂直 vertical	水平 horizontal		纵 lengthways	横 crosswise
						100	500	110
						200	250	55
						300	167	37
						500	100	22
						容许力矩 Allowable moment (N·m)	50	11

28 series technical data

28J-7

滑动负载 (N) Slide the load	900	纵 lengthways		横 crosswise		力矩负载 Torque load	长度 Length (mm)	容许负载 Allow the load (N)	
		纵 lengthways	横 crosswise	纵 lengthways	横 crosswise			纵 lengthways	横 crosswise
				(N)	180	140	100	85	
					200	43			
					300	28			
					500	17			
					容许力矩 Allowable moment (N·m)	16	12.5		8.5

28J-8

滑动负载 (N) Slide the load	800	力矩负载 Torque load		长度 Length (mm)	容许负载 Allow the load (N)	
		垂直 vertical	水平 horizontal		纵 lengthways	横 crosswise
				100	100	65
				200	50	33
				300	33	22
				500	20	13
				容许力矩 Allowable moment (N·m)	10	6.5

28J-9A

滑动负载 (N) Slide the load	300	力矩负载 Torque load 容许力矩 (N·m) Allowable moment	400 11.4	力矩负载 Torque load		长度 Length (mm)	容许负载 Allow the load (N)	
				横向使用 Lateral use			横向使用 Lateral use	
					100	85		
					200	43		
					300	28		
					500	17		
					容许力矩 Allowable moment (N·m)	8.5		

28J-9

滑动负载 (N) Slide the load	300	力矩负载 Torque load 容许力矩 (N·m) Allowable moment	400 10	力矩负载 Torque load		长度 Length (mm)	容许负载 Allow the load (N)	
				横向使用 Lateral use			横向使用 Lateral use	
					100	72		
					200	36		
					300	24		
					500	14		
					容许力矩 Allowable moment (N·m)	7.2		

28J-9B

滑动负载 (N) Slide the load	300	力矩负载 Torque load 容许力矩 (N·m) Allowable moment	400 8	力矩负载 Torque load		长度 Length (mm)	容许负载 Allow the load (N)	
				横向使用 Lateral use			横向使用 Lateral use	
					100	85		
					200	43		
					300	28		
					500	17		
					容许力矩 Allowable moment (N·m)	8.5		

28 series technical data

28J-11

滑动负载 (N) Slide the load	1500	拉伸负载 (N) Tensile load	600	力矩负载 Torque load		长度 Length (mm)	容许负载 Allow the load (N)	
				垂直 vertical	水平 horizontal		纵 lengthways	横 crosswise
						100	330	120
						200	165	60
						300	110	40
						500	66	24
						容许力矩 Allowable moment (N·m)	33	12

28J-12

拉伸负载 (N) Tensile load	420	力矩负载 Torque load	长度 Length (mm)	容许负载 Allow the load (N)	
				纵 lengthways	横 crosswise
			100	50	
			200	25	
			300	16	
			500	10	
			容许力矩 Allowable moment (N·m)	5	

28J-13

滑动负载 (N) Slide the load	200	拉伸负载 (N) Tensile load	130	力矩负载 Torque load		长度 Length (mm)	容许负载 Allow the load (N)	
				垂直 vertical	水平 horizontal		纵 lengthways	横 crosswise
						100	50	20
						200	25	10
						300	17	7
						500	10	4
						容许力矩 Allowable moment (N·m)	5	2

28J-14

滑动负载 (N) Slide the load	960	力矩负载 Torque load	500	力矩负载 Torque load		长度 Length (mm)	容许负载 Allow the load (N)	
				横向使用 Lateral use			横向使用 Lateral use	
					100	180		
					200	90		
					300	60		
					500	36		
					容许力矩 Allowable moment (N·m)	18		

28J-15

滑动负载 (N) Slide the load	800	拉伸负载 (N) Tensile load	无螺丝 420 有螺丝 1500	力矩负载 Torque load		长度 Length (mm)	容许负载 Allow the load (N)	
				垂直 vertical	水平 horizontal		纵 lengthways	横 crosswise
						100	110	55
						200	55	28
						300	37	18
						500	22	11
						容许力矩 Allowable moment (N·m)	11	5.5



28 series technical data

28J-20

滑动负载 (N) Slide the load	350	拉伸负载 (N) Tensile load	350	力矩负载 Torque load		长度 Length (mm)	容许负载 Allow the load (N)	
	垂直 vertical		水平 horizontal		纵 lengthways		横 crosswise	
				100	30	40		
				200	15	20		
				300	10	13		
				500	6	8		
				容许力矩 Allowable moment (N·m)	3	4		

28J-21

滑动负载 (N) Slide the load	650	力矩负载 Torque load		长度 Length (mm)	容许负载 Allow the load (N)	
垂直 vertical		水平 horizontal			纵 lengthways	横 crosswise
			100	160	75	
			200	80	38	
			300	53	25	
			500	32	15	
			容许力矩 Allowable moment (N·m)	16	7.5	

28J-22

滑动负载 (N) Slide the load	700	拉伸负载 (N) Tensile load	350	力矩负载 Torque load		长度 Length (mm)	容许负载 Allow the load (N)	
	垂直 vertical		水平 horizontal		纵 lengthways		横 crosswise	
				100	90	60		
				200	45	30		
				300	30	20		
				500	18	12		
				容许力矩 Allowable moment (N·m)	9	6		

28J-23

滑动负载 (N) Slide the load	280	力矩负载 Torque load	110

28J-25A-56

滑动负载 (N) Slide the load	600	力矩负载 Torque load 容许力矩 (N·m) Allowable moment	400 11.4	力矩负载 Torque load		长度 Length (mm)	容许负载 Allow the load (N)	
	横向使用 Lateral use		纵 lengthways	横 crosswise				
			100	170				
			200	85				
			300	56				
			500	34				
			容许力矩 Allowable moment (N·m)	17				

28 series technical data

28J-25A-100

滑动负载 (N) Slide the load	600	力矩负载 Torque load 容许力矩 (N·m) Allowable moment	400 11.4	力矩负载 Torque load		长度 Length (mm)	容许负载 Allow the load (N)
	横向使用 Lateral use						
			200	85			
			300	56			
			500	34			
			容许力矩 Allowable moment (N·m)	17			

28J-25B-56

滑动负载 (N) Slide the load	600	力矩负载 Torque load 容许力矩 (N·m) Allowable moment	400 10	力矩负载 Torque load		长度 Length (mm)	容许负载 Allow the load (N)
	横向使用 Lateral use						
			100	144			
			200	72			
			300	48			
			500	28			
			容许力矩 Allowable moment (N·m)	14.4			

28J-25B-100

滑动负载 (N) Slide the load	600	力矩负载 Torque load 容许力矩 (N·m) Allowable moment	400 10	力矩负载 Torque load		长度 Length (mm)	容许负载 Allow the load (N)
	横向使用 Lateral use						
			100	144			
			200	72			
			300	48			
			500	28			
			容许力矩 Allowable moment (N·m)	14.4			

28J-26

	280	纵 lengthways	横 crosswise	纵 lengthways	横 crosswise	力矩负载 Torque load	长度 Length (mm)	容许负载 Allow the load (N)
	容许负载 Allow the load (N)							
			290	370	23.2	30.8	100	100
			200	50				
			300	33				
			500	20				
			容许力矩 Allowable moment (N·m)	10				

28J-27-50

滑动负载 (N) Slide the load	500	拉伸负载 (N) Tensile load	230	力矩负载 Torque load		长度 Length (mm)	容许负载 Allow the load (N)	
	垂直 vertical		水平 horizontal		纵 lengthways		横 crosswise	
				100	80	20		
				200	40	10		
				300	26	6		
				500	16	4		
				容许力矩 Allowable moment (N·m)	8	2		

28 series technical data

28J-27-100

滑动负载 (N) Slide the load	500	拉伸负载 (N) Tensile load	230	力矩负载 Torque load		长度 Length (mm)	容许负载 Allow the load (N)	
				垂直 vertical	水平 horizontal		纵 lengthways	横 crosswise
						100	80	20
						200	40	10
						300	26	6
						500	16	4
						容许力矩 Allowable moment (N·m)	8	2

28J-27A

滑动负载 (N) Slide the load	583	力矩负载 Torque load		长度 Length (mm)	容许负载 Allow the load (N)	
		垂直 vertical	水平 horizontal		纵 lengthways	横 crosswise
				100	101	41
				200	51	21
				300	33	14
				500	20	8
				容许力矩 Allowable moment (N·m)	10.1	4.1

28J-27B

滑动负载 (N) Slide the load	852	力矩负载 Torque load		长度 Length (mm)	容许负载 Allow the load (N)	
		垂直 vertical	水平 horizontal		纵 lengthways	横 crosswise
				100	115	49
				200	58	25
				300	38	16
				500	23	10
				容许力矩 Allowable moment (N·m)	11.5	4.9

28J-29

滑动负载 (N) Slide the load	800	拉伸负载 (N) Tensile load	无螺丝 420 有螺丝 1500	力矩负载 Torque load		长度 Length (mm)	容许负载 Allow the load (N)	
				垂直 vertical	水平 horizontal		纵 lengthways	横 crosswise
						100	110	55
						200	55	28
						300	37	18
						500	22	11
						容许力矩 Allowable moment (N·m)	11	5.5

28AD-1B

压缩负重 (N) Compression load	树脂 resin 1250 导电树脂 Conductive resin 500	拉伸负载 (N) Tensile load	树脂 resin 120 导电树脂 Conductive resin 120	容许力矩 Allowable moment (N·m)		树脂 resin 62 导电树脂 Conductive resin 60

28 series technical data

28AD-2

耐负荷 (N) Resistance load	3250

28AD-4

容许负载 (N) Allow the load	600	拉伸负载 (N) Tensile load	240	力矩负载 Torque load		长度 Length (mm)	允许负重 Allow the load (N)	
				垂直 vertical	水平 horizontal		纵 lengthways	横 crosswise
				100	700	500		
				200	350	250		
				300	233	167		
				500	140	100		
				容许力矩 Allowable moment (N·m)	70	50		

28AD-5B

力矩负载 Torque load		长度 Length (mm)	允许负重 Allow the load (N)	
		F1	F2	
		500	108	102
		1000	54	51
		1500	36	34
		2000	27	25.5
		容许力矩 Allowable moment (N·m)	54	51

28AD-5C

力矩负载 Torque load		长度 Length (mm)	允许负重 Allow the load (N)	
		F1	F2	
		500	114	78
		1000	57	39
		1500	38	26
		2000	28.5	19.5
		容许力矩 Allowable moment (N·m)	57	39

28AD-5D

力矩负载 Torque load		长度 Length (mm)	F1	F2	F3
		500	132	116	112
		1000	66	58	56
		1500	44	38.5	37
		2000	33	29	28
		容许力矩 Allowable moment (N·m)	66	58	56



28 series technical data

**28AD-6**

耐负荷 (N) Resistance load	1900
----------------------------	------

**28AD-7**

滑动负载 (N) Slide the load	900
----------------------------	-----

力矩负载 Torque load

长度 Length (mm)	容许负载 Allow the load (N)
100	470
200	235
300	157
500	94
容许力矩 Allowable moment (N·m)	47

**28AT-1**

摇臂 rocker arm	450
---------------	-----

推力 push

750
-----

**28AT-2A**

力矩负载 Torque load	长度 Length (mm)	容许负载 Allow the load (N)
	100	180
	200	90
	300	60
	500	36
容许力矩 Allowable moment (N·m)		18

**28AT-2B**

力矩负载 Torque load	长度 Length (mm)	容许负载 Allow the load (N)
	100	180
	200	90
	300	60
	500	36
容许力矩 Allowable moment (N·m)		18

**28AT-3A**

滑动负载 (N) Slide the load	350
-------------------------	-----

**28AT-3B**

滑动负载 (N) Slide the load	750
-------------------------	-----

**28AT-5**

滑动负载 (N) Slide the load	800
-------------------------	-----

**28AT-6**

容许力矩 (N·m) Allowable moment	9
-----------------------------	---

**28AT-7**

耐负荷 (N) Resistance load	50
-------------------------	----

寿命: 120km

28 series technical data

**28AT-9**

耐负荷 (N) Resistance load	150
-------------------------	-----

**28AT-10**

耐负荷 (N) Resistance load	150
-------------------------	-----

**28AT-12A**

耐负荷 (N) Resistance load	30
-------------------------	----

**28AT-12B**

耐负荷 (N) Resistance load	30
-------------------------	----

**28AT-14**

耐负荷 (N) Resistance load	600
-------------------------	-----

**28AT-15A**

滑动性 (使用2个)(N) slide(Use 2)	10
----------------------------	----

滑动性 (向下负荷) slide(Load down)

40
----

滑动性 (向上负荷) slide(Load up)

20
----

**28AT-15B**

力矩负载 Torque load	110
容许负载 Allow the load(N)	2.2

**28AT-17**

力矩负载 Torque load	长度 Length (mm)	容许负载 (N) Allow the load
	100	640
	200	320
	300	213
	500	128
容许力矩 Allowable moment (N·m)		64

**28AT-22**

耐负荷 (N) Resistance load	100
-------------------------	-----

**28AT-24**

耐负荷 (N) Resistance load	200
-------------------------	-----

**28AT-26A**

耐负荷 (N) Resistance load	200
-------------------------	-----

**28AT-26B**

耐负荷 (N) Resistance load	600
-------------------------	-----

28 series technical data

**28AT-26C**

耐负荷 (N) Resistance load	130
-------------------------	-----

**28AT-32**

滑动负荷 (N) Slide the load	250
-------------------------	-----

**28AC-1**

滑动负荷 (N) Slide the load	250	力矩负载 Torque load	260
		容许力矩 (N·m) Allowable moment	13

**28AC-2**

滑动负荷 (N) Slide the load	230	力矩负载 Torque load	260
		容许力矩 (N·m) Allowable moment	8

**28AC-3**

滑动负荷 (N) Slide the load	410	力矩负载 Torque load	500
		容许力矩 (N·m) Allowable moment	6

**28AC-3**

滑动负荷 (N) Slide the load	400	力矩负载 Torque load	500
		容许力矩 (N·m) Allowable moment	5.75

**28AC-4**

容许力矩负载 (N·m) Allowable moment load	1.0
------------------------------------	-----

**28AC-5**

容许力矩负载 (N·m) Allowable moment load	6.5
------------------------------------	-----

**28AC-8**

滑动负荷 (N) Slide the load	195
-------------------------	-----

**28AT-18**

力矩负载 Torque load	300
------------------	-----

**28AT-23A**

滑动负荷 (N) Slide the load	10
-------------------------	----

28 series technical data

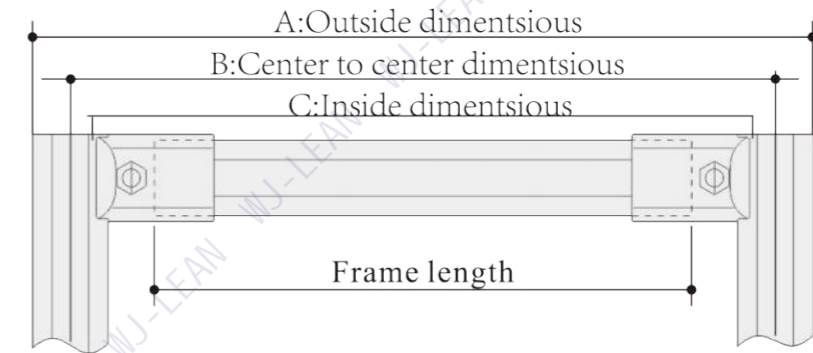

■ AP-28A

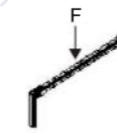

管道长度 (mm) Pipe length	最大允许力 5/1000 Maximum allowable force	使用推荐负荷 Use recommended load	最大负荷 (N) Maximum load
500	2.5	779	1162
1000	5	135	581

■ AP-28B



〈横〉

管道长度 (mm) Pipe length	最大允许力 5/1000 Maximum allowable force	使用推荐负荷 Use recommended load	最大负荷 (N) Maximum load
500	2.5	1300	1400
1000	5	334	994

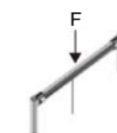

〈纵〉

管道长度 (mm) Pipe length	最大允许力 5/1000 Maximum allowable force	使用推荐负荷 Use recommended load	最大负荷 (N) Maximum load
500	2.5	799	1344
1000	5	200	672

■ AP-28C

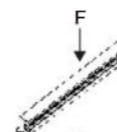

〈横〉

管道长度 (mm) Pipe length	最大允许力 5/1000 Maximum allowable force	使用推荐负荷 Use recommended load	最大负荷 (N) Maximum load
500	2.5	1600	1600
1000	5	283	966

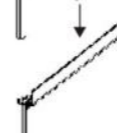

〈纵〉

管道长度 (mm) Pipe length	最大允许力 5/1000 Maximum allowable force	使用推荐负荷 Use recommended load	最大负荷 (N) Maximum load
500	2.5	1600	1540
1000	5	507	770

■ AP-28D



〈横〉

管道长度 (mm) Pipe length	最大允许力 5/1000 Maximum allowable force	使用推荐负荷 Use recommended load	最大负荷 (N) Maximum load
500	2.5	1540	1600
1000	5	511	868



〈纵〉

管道长度 (mm) Pipe length	最大允许力 5/1000 Maximum allowable force	使用推荐负荷 Use recommended load	最大负荷 (N) Maximum load
500	2.5	1600	1600
1000	5	430	854



28 series technical data

■ AP-28E

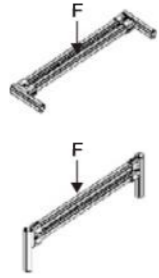

〈横〉

管道长度 (mm) Pipe length	最大允许力 5/1000 Maximum allowable force	使用推荐负荷 Use recommended load	最大负荷 (N) Maximum load
500	2.5	1552	2310
1000	5	388	1155

〈縦〉

管道长度 (mm) Pipe length	最大允许力 5/1000 Maximum allowable force	使用推荐负荷 Use recommended load	最大负荷 (N) Maximum load
500	2.5	2000	2000
1000	5	1958	2000

■ AP-28F

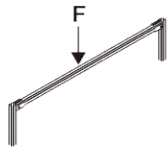

管道长度 (mm) Pipe length	最大允许力 5/1000 Maximum allowable force	使用推荐负荷 Use recommended load	最大负荷 (N) Maximum load
500	2.5	1155	1600
1000	5	289	861

■ AP-28G

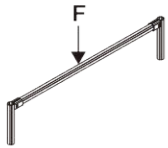

管道长度 (mm) Pipe length	最大允许力 5/1000 Maximum allowable force	使用推荐负荷 Use recommended load	最大负荷 (N) Maximum load
500	2.5	1350	1600
1000	5	338	1008

■ AP-28H



管道长度 (mm) Pipe length	最大允许力 5/1000 Maximum allowable force	使用推荐负荷 Use recommended load	最大负荷 (N) Maximum load
500	2.5	987	1414
1000	5	247	707

■ AP-28J

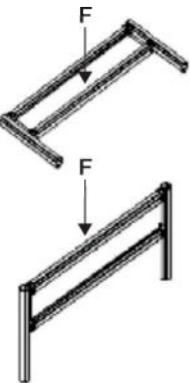

〈横〉

管道长度 (mm) Pipe length	最大允许力 5/1000 Maximum allowable force	使用推荐负荷 Use recommended load	最大负荷 (N) Maximum load
500	2.5	1558	2310
1000	5	390	1155

〈縦〉

管道长度 (mm) Pipe length	最大允许力 5/1000 Maximum allowable force	使用推荐负荷 Use recommended load	最大负荷 (N) Maximum load
500	2.5	3200	3200
1000	5	3200	3200

■ AP-28G

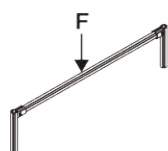

管道长度 (mm) Pipe length	最大允许力 5/1000 Maximum allowable force	使用推荐负荷 Use recommended load	最大负荷 (N) Maximum load
500	2.5	1350	1600
1000	5	338	1008

19 series technical data

19J-1

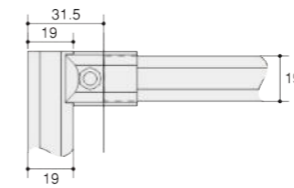

$$l = A - (31.5 \times 2)$$

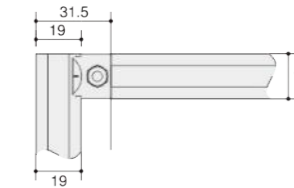

$$l = A - (31.75 \times 2)$$

19J-1B

19J-2

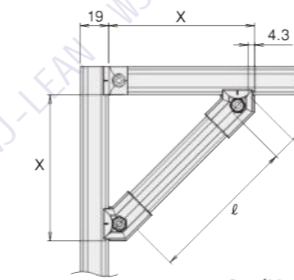

$$l = (X - 4.3) \times \sqrt{2} - 31.4$$

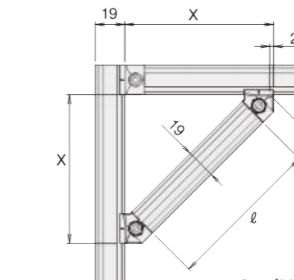

$$l = (X - 2.5) \times \sqrt{2} - 31.4$$

19J-3

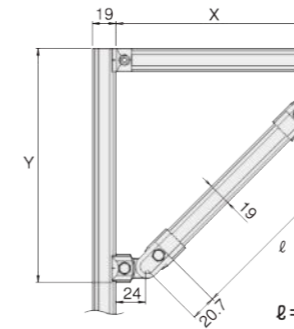

$$l = \sqrt{(X - 24)^2 + (Y - 24)^2} - 41.4$$

19J-4

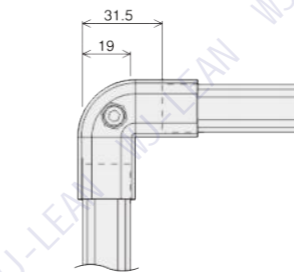

$$l = A - (31.5 \times 2)$$

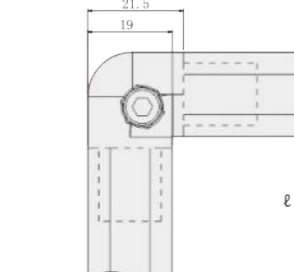

$$l = A - (21.5 \times 2)$$

19 series technical data

19J-1

力矩负载 Torque load	360	拉伸负载 (N) Tensile load	300	力矩负载 Torque load		长度 Length (mm)	容许负载 Allow the load (N)	
				垂直 vertical	水平 horizontal		纵 lengthways	横 crosswise
						100	30	12
						200	15	6
						300	10	4
						500	6	2
						容许力矩 Allowable moment (N·m)	3	1.2

19J-1B

力矩负载 Torque load	360	拉伸负载 (N) Tensile load	300	力矩负载 Torque load		长度 Length (mm)	容许负载 Allow the load (N)	
				垂直 vertical	水平 horizontal		纵 lengthways	横 crosswise
						100	30	12
						200	15	6
						300	10	4
						500	6	2
						容许力矩 Allowable moment (N·m)	3	1.2

19J-2

滑动负载 (N) Slide the load	330	拉伸负载 (N) Tensile load	220	力矩负载 Torque load	长度 Length (mm)	容许负载 Allow the load (N)	
						纵 lengthways	横 crosswise
					100	30	
					200	15	
					300	10	
					500	6	
					容许力矩 Allowable moment (N·m)	3	

19J-3

滑动负载 (N) Slide the load	280	拉伸负载 (N) Tensile load	300

19J-4

拉伸负载 (N) Tensile load	130	力矩负载 Torque load		长度 Length (mm)	容许负载 Allow the load (N)	
		垂直 vertical	水平 horizontal		纵 lengthways	横 crosswise
				100	90	50
				200	45	25
				300	30	17
				500	18	10
				容许力矩 Allowable moment (N·m)	9	5

19 series technical data

19J-5

拉伸负载 (N) Tensile load	535	力矩负载 Torque load		长度 Length (mm)	容许负载 Allow the load (N)	
		垂直 vertical	水平 horizontal		纵 lengthways	横 crosswise
				100	170	15
				200	85	7.5
				300	57	5
				500	34	3
				容许力矩 Allowable moment (N·m)	17	1.5

19J-6

滑动负载 (N) Slide the load	240	力矩负载 Torque load 容许力矩 (N·m) Allowable moment	259 7	力矩负载 Torque load	长度 Length (mm)	容许负载 Allow the load (N)	
				横向使用 Lateral use		纵 lengthways	横 crosswise
					100	50	
					200	25	
					300	17	
					500	10	
					容许力矩 Allowable moment (N·m)	5	

19J-7

滑动负载 (N) Slide the load	200	力矩负载 Torque load 容许力矩 (N·m) Allowable moment	90 3.3	力矩负载 Torque load	长度 Length (mm)	容许负载 Allow the load (N)	
				横向使用 Lateral use		纵 lengthways	横 crosswise
					100	20	
					200	10	
					300	6.6	
					500	4	
					容许力矩 Allowable moment (N·m)	2	

19J-8

滑动负载 (N) Slide the load	650	力矩负载 Torque load		长度 Length (mm)	容许负载 Allow the load (N)	
		垂直 vertical	水平 horizontal		纵 lengthways	横 crosswise
				100	80	30
				200	40	15
				300	27	10
				500	16	6
				容许力矩 Allowable moment (N·m)	8	3



19 series technical data

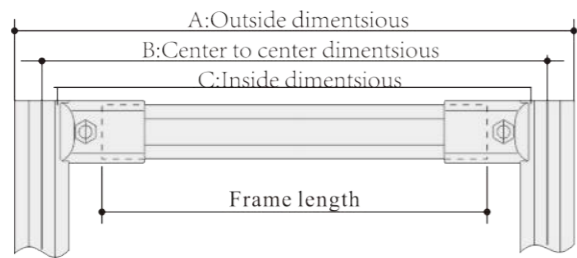

■ AP-19A



管道长度 (mm) Pipe length	最大允许力 5/1000 Maximum allowable force	使用推荐负荷 Use recommended load	最大负荷 (N) Maximum load
500	2.5	181	300
1000	5	45	196

■ AP-19B



〈横〉			
管道长度 (mm) Pipe length	最大允许力 5/1000 Maximum allowable force	使用推荐负荷 Use recommended load	最大负荷 (N) Maximum load
500	2.5	257	560
1000	5	64	282

〈縦〉			
管道长度 (mm) Pipe length	最大允许力 5/1000 Maximum allowable force	使用推荐负荷 Use recommended load	最大负荷 (N) Maximum load
500	2.5	133	252
1000	5	33	126

■ AP-19C



〈横〉			
管道长度 (mm) Pipe length	最大允许力 5/1000 Maximum allowable force	使用推荐负荷 Use recommended load	最大负荷 (N) Maximum load
500	2.5	300	300
1000	5	136	300

〈縦〉			
管道长度 (mm) Pipe length	最大允许力 5/1000 Maximum allowable force	使用推荐负荷 Use recommended load	最大负荷 (N) Maximum load
500	2.5	300	300
1000	5	144	300

■ AP-19D

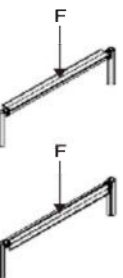

〈横〉			
管道长度 (mm) Pipe length	最大允许力 5/1000 Maximum allowable force	使用推荐负荷 Use recommended load	最大负荷 (N) Maximum load
500	2.5	300	300
1000	5	154	300

〈縦〉			
管道长度 (mm) Pipe length	最大允许力 5/1000 Maximum allowable force	使用推荐负荷 Use recommended load	最大负荷 (N) Maximum load
500	2.5	300	300
1000	5	156	300

■ AP-19G

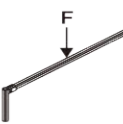

管道长度 (mm) Pipe length	最大允许力 5/1000 Maximum allowable force	使用推荐负荷 Use recommended load	最大负荷 (N) Maximum load
500	2.5	343	560
1000	5	86	378

43 series technical data

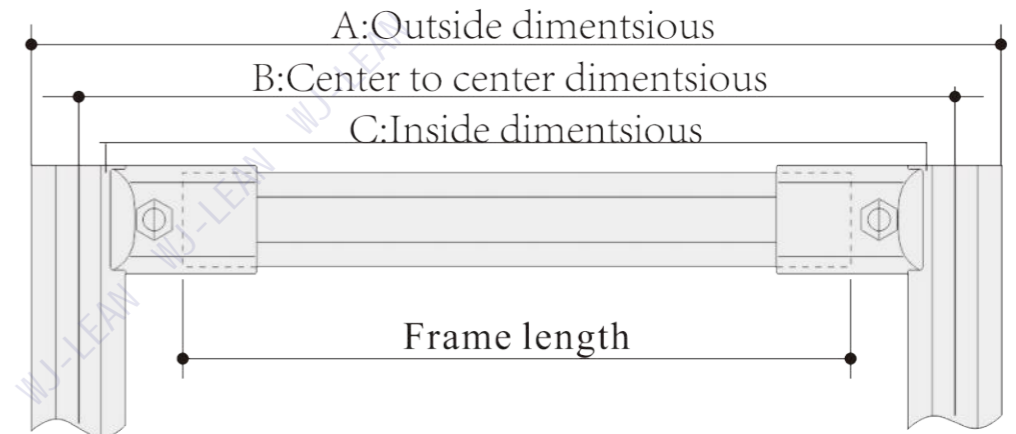

43J-1

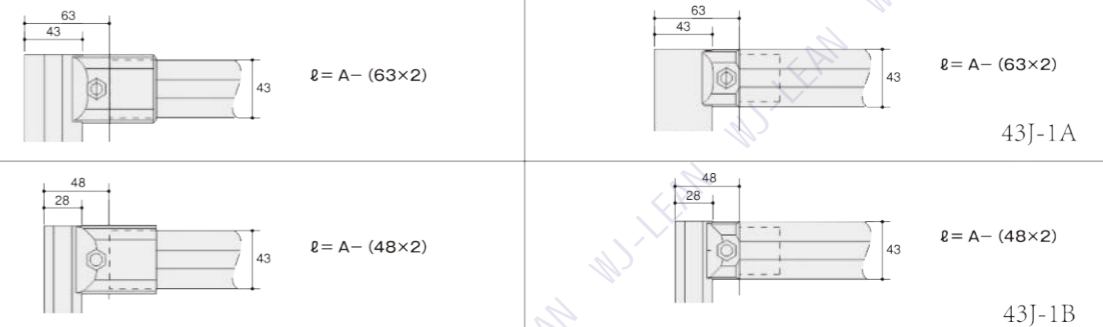

43J-4

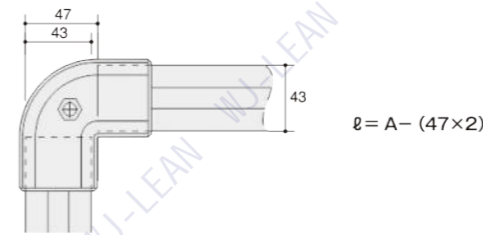



43J-1B

滑动负载 (N) Slide the load	1700	拉伸负载 (N) Tensile load	1000	力矩负载 Torque load		长度 Length (mm)	容许负载 Allow the load (N)	
				垂直 vertical	水平 horizontal		纵 lengthways	横 crosswise
						100	500	300
						200	250	150
						300	167	100
						500	100	60
容许力矩 Allowable moment (N·m)							50	30

43 series technical data

43J-1

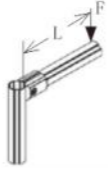
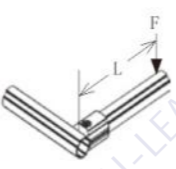
滑动负载 (N) Slide the load	2500	拉伸负载 (N) Tensile load	690	力矩负载 Torque load		长度 Length (mm)	容许负载 Allow the load (N)	
				垂直 vertical	水平 horizontal		纵 lengthways	横 crosswise
						100	660	150
						200	330	75
						300	220	50
						500	132	30
						容许力矩 Allowable moment (N·m)	66	15

43J-2

拉伸负载 (N) Tensile load	260	力矩负载 Torque load		长度 Length (mm)	容许负载 Allow the load (N)	
		垂直 vertical	水平 horizontal		纵 lengthways	横 crosswise
				100	1700	90
				200	850	45
				300	567	30
				500	340	18
				容许力矩 Allowable moment (N·m)	170	9

■ AP-43A

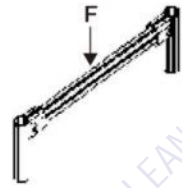

管道长度 (mm) Pipe length	最大允许力 5/1000 Maximum allowable force	使用推荐负荷 Use recommended load	最大负荷 (N) Maximum load
500	2.5	1800	1800
1000	5	851	1652

■ AP-43B

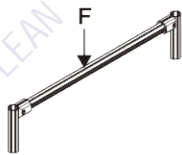

管道长度 (mm) Pipe length	最大允许力 5/1000 Maximum allowable force	使用推荐负荷 Use recommended load	最大负荷 (N) Maximum load
500	2.5	1800	1800
1000	5	972	1800

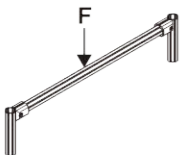

管道长度 (mm) Pipe length	最大允许力 5/1000 Maximum allowable force	使用推荐负荷 Use recommended load	最大负荷 (N) Maximum load
500	2.5	1800	1800
1000	5	875	1701

■ AP-43G

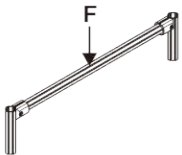

管道长度 (mm) Pipe length	最大允许力 5/1000 Maximum allowable force	使用推荐负荷 Use recommended load	最大负荷 (N) Maximum load
500	2.5	1800	1800
1000	5	1542	1800